

- NOTES
1. LEAD CO-PLANARITY SHALL BE 0.1mm MAX.
 2. STIFFENER IS REQUIRED FOR MOUNTING ONTO FPC IN ORDER TO AVOID STRESS BY FPC SLACKING TO MOUNTED CONNECTOR.
 3. UNMATING SHALL BE DONE WITH THE SPECIFIC EXTRACTION TOOL.

3	PHOSPHOR BRONZE	WHOLE AREA : Au PLATING 0.1μm min UNDER PLATING : Ni PLATING 2μm min	7	PS	BLACK
2	LCP	UL94V-0 . BLACK	6	POLYESTER	CLEAR
1	PHOSPHOR BRONZE	CONTACT AREA : Au PLATING 0.3μm min LEAD AREA : Au PLATING 0.1μm min UNDER PLATING : Ni PLATING 2μm min	5	PS	CLEAR
NO.	MATERIAL	FINISH . REMARKS	NO.	MATERIAL	FINISH . REMARKS
UNITS mm		SCALE 5 : 1	COUNT △	DESCRIPTION OF REVISIONS	
DESIGNED		CHECKED		DATE	
APPROVED : TS. SAKATA			10.10.05		
CHECKED : HS. OZAWA			10.10.05		
DESIGNED : TP. MATSUMOTO			10.10.05		
DRAWN : TP. MATSUMOTO			10.10.05		
DRAWING NO.				EDC3-320369-03	
PART NO.				DF36-20S-0.4V(52)	
CODE NO.				CL662-4039-3-52	
				△ 1/2	

Apr.1.2017 Copyright 2017 HIROSE ELECTRIC CO., LTD. All Rights Reserved.

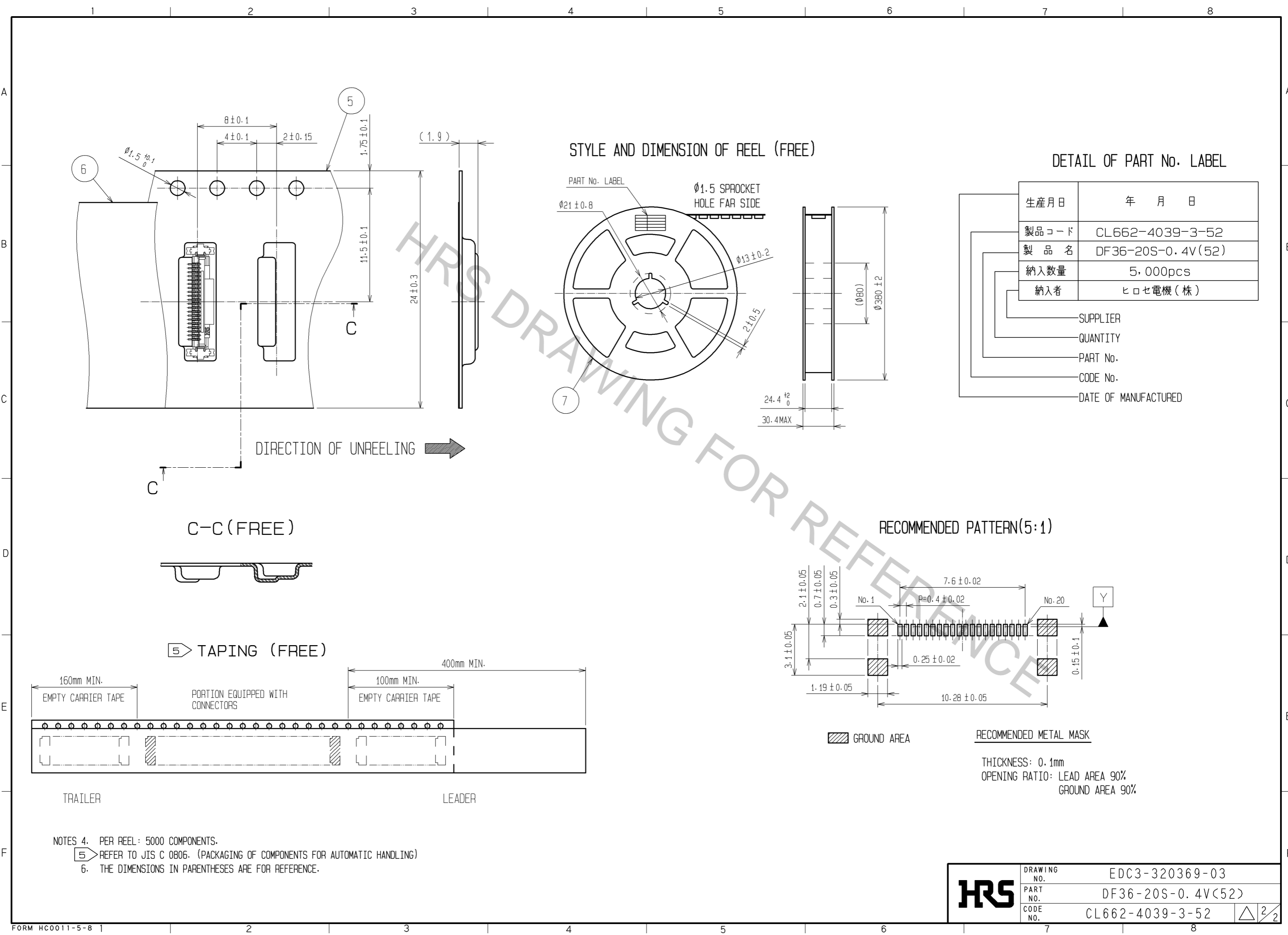

STYLE AND DIMENSION OF REEL (FREE)

DETAIL OF PART No. LABEL

生産月日	年 月 日
製品コード	CL662-4039-3-52
製品名	DF36-20S-0.4V(52)
納入数量	5,000pcs
納入者	ヒロセ電機(株)

SUPPLIER
QUANTITY
PART No.
CODE No.
DATE OF MANUFACTURED

RECOMMENDED PATTERN(5:1)

RECOMMENDED METAL MASK
THICKNESS: 0.1mm
OPENING RATIO: LEAD AREA 90%
GROUND AREA 90%

NOTES 4. PER REEL: 5000 COMPONENTS.
5 REFER TO JIS C 0806. (PACKAGING OF COMPONENTS FOR AUTOMATIC HANDLING)
6. THE DIMENSIONS IN PARENTHESES ARE FOR REFERENCE.

HRS	DRAWING NO.	EDC3-320369-03
	PART NO.	DF36-20S-0.4V(52)
	CODE NO.	CL662-4039-3-52
		△ 2/2