

Apr.1.2017 Copyright 2017 HIROSE ELECTRIC CO., LTD. All Rights Reserved.

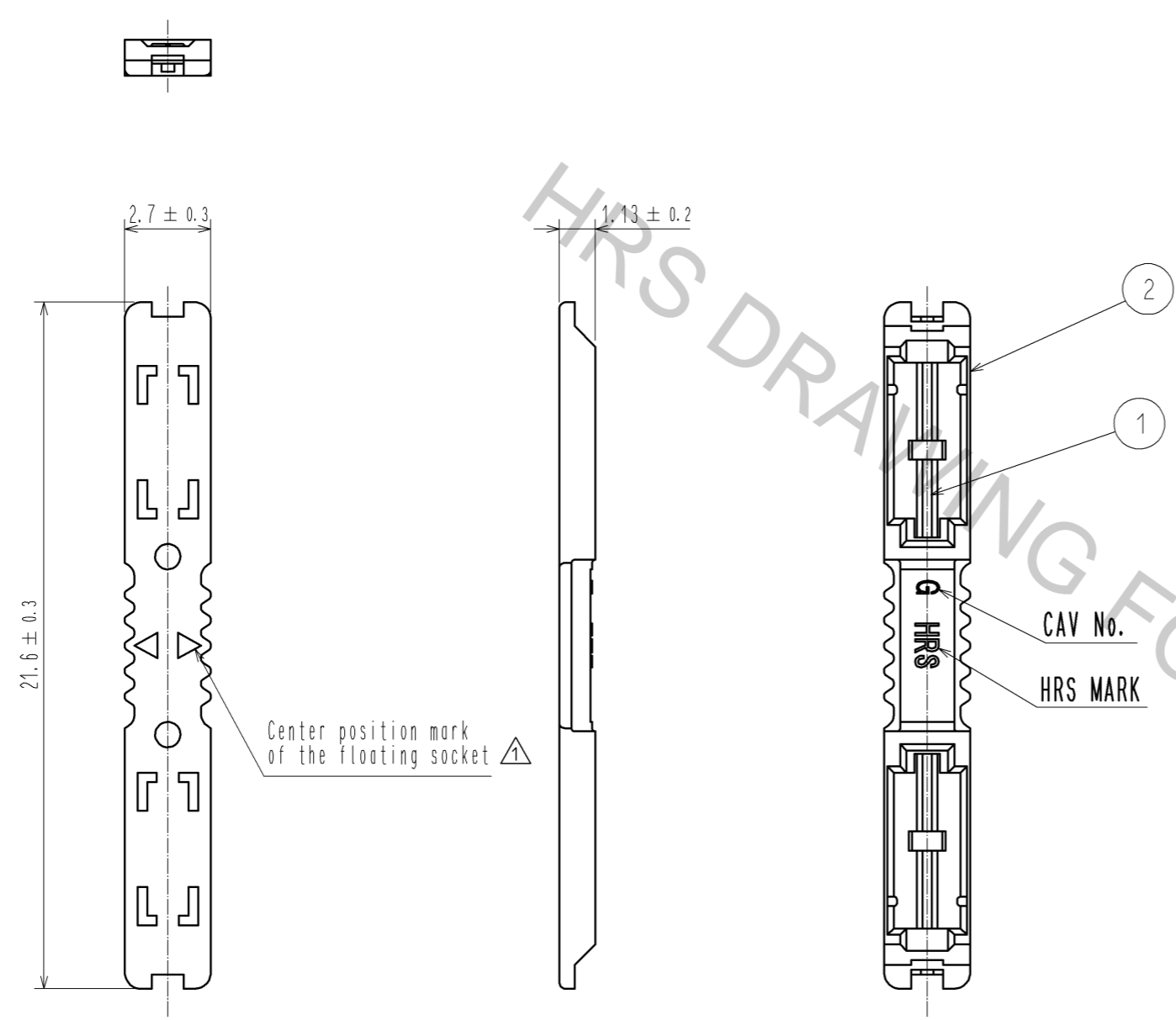

NOTE1. REFER TO THE DF59S SERIES MATING/UNMATING OPERATION INSTRUCTION MANUAL (ETAD-H0651) FOR THE OPERATING OF THE PRODUCT.

2	LCP	UL94V-0, BEIGE	5	PS	REEL, BLACK
1	BRASS	SURFACE:TIN PLATING 1 μ m MIN UNDER PLATING:Cu PLATING 0.3 μ m MIN	4	POLYESTER	CLEAR(COVER TAPE)
			3	PS	CLEAR(EMBOSSSED CARRIER TAPE)
NO.	MATERIAL	FINISH, REMARKS	NO.	MATERIAL	FINISH, REMARKS
UNITS mm		SCALE 5 : 1	COUNT \triangle 1	DESCRIPTION OF REVISIONS DIS-H-007568	
			DESIGNED MI. SAKIMURA	CHECKED TS. KUMAZAWA	DATE 13.01.23
HRS HIROSE ELECTRIC CO., LTD.			APPROVED : KI. AKIYAMA 12.11.14	DRAWING NO. EDC3-342886-03	
			CHECKED : OM. MIYAMOTO 12.11.14	PART NO. DF59S-1P-FC(24)	
			DESIGNED : KT. ISHII 12.11.13	CODE NO. CL667-0023-3-24	
			DRAWN : KT. ISHII 12.11.13	\triangle 1/4	

Apr.1.2017 Copyright 2017 HIROSE ELECTRIC CO., LTD. All Rights Reserved.

1 2 3 4 5 6 7 8

A
B
C
D
E
F

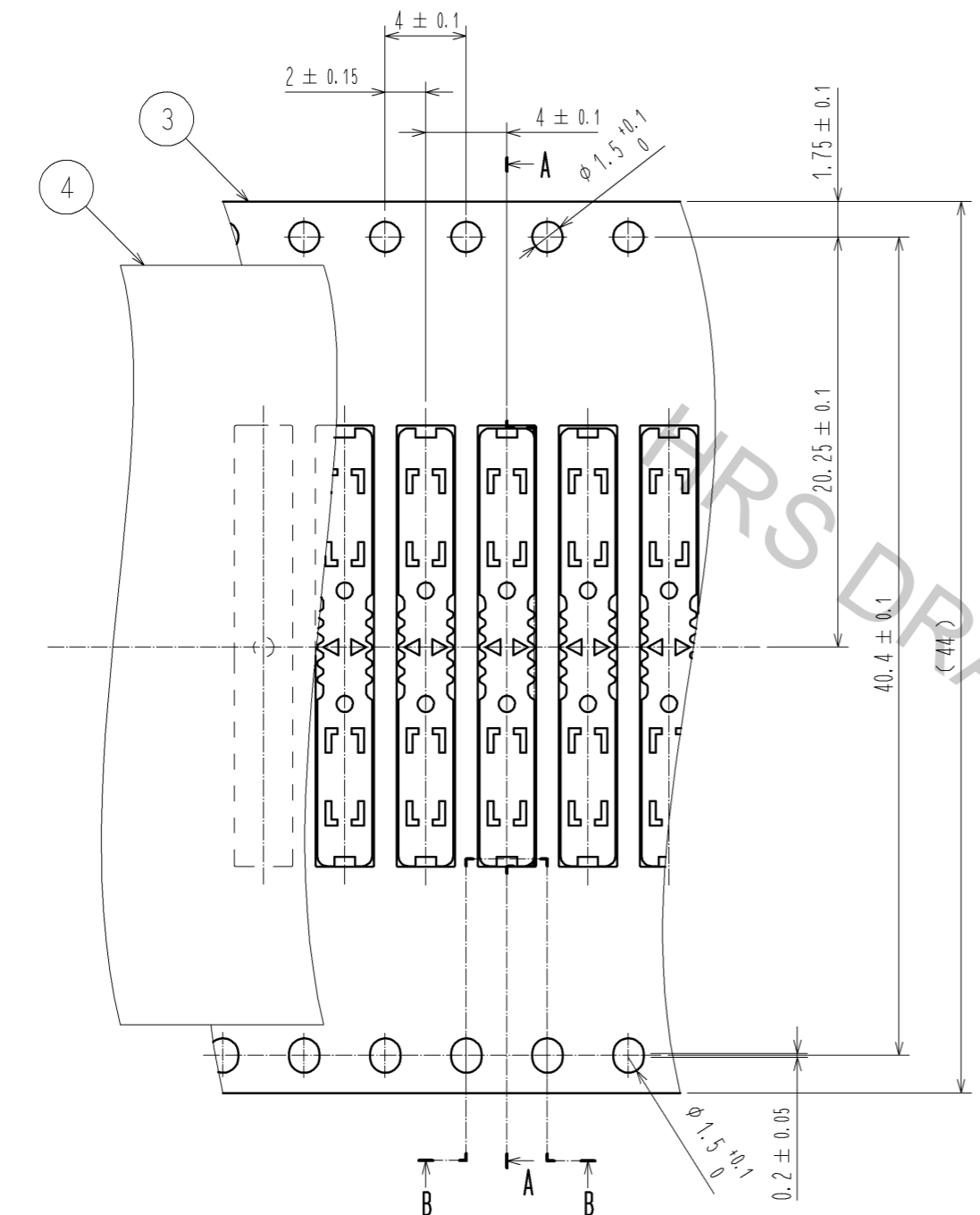

B-B(FREE)

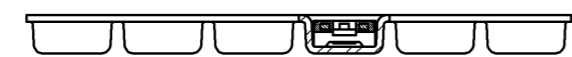

DIRECTION OF UNREELING →

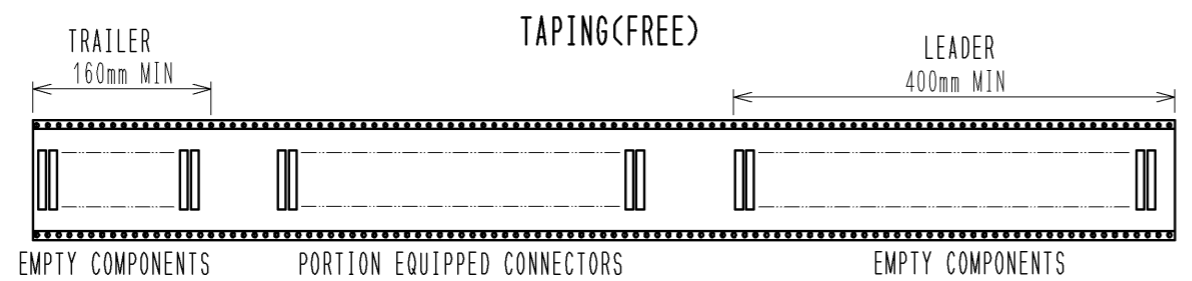

A-A(FREE)

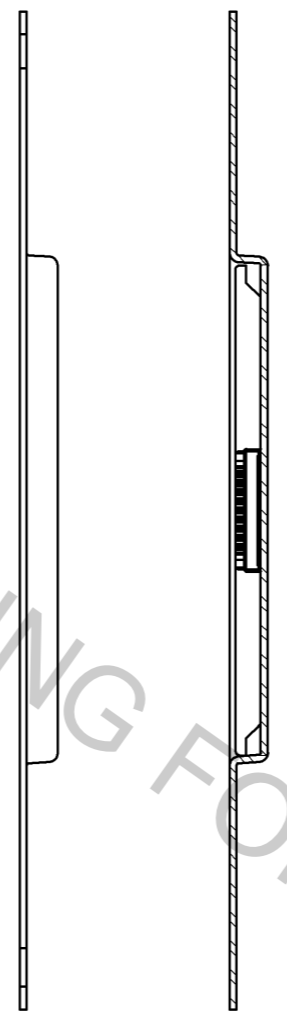

STYLE AND DIMENSION OF REEL(FREE)

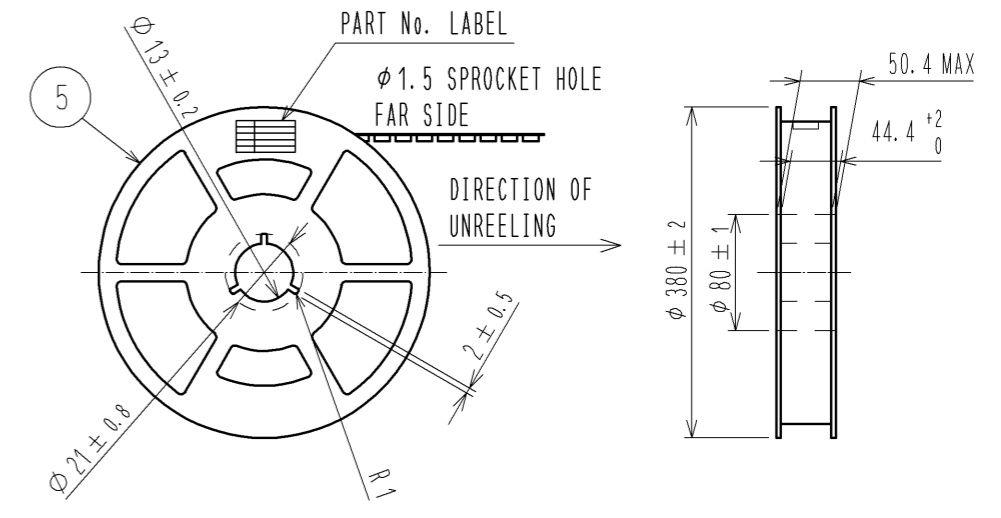

DETAIL OF PART No. LABEL

生産月日	年 月 日
図 番	CL667-0023-3-24
品 名	DF59S-1P-FC(24)
納入数量	1000 KO
納入者	ヒロセ電機(株)

NOTE2. 1REEL:1000 CONNECTORS.
3. THE DIMENSIONS IN PARENTHESES ARE FOR REFERENCE.

HRS	DRAWING NO.	EDC3-342886-03
	PART NO.	DF59S-1P-FC(24)
	CODE NO.	CL667-0023-3-24
		2/4

FORM HC0011-5-8 1 2 3 4 5 6 7 8

DF59S Operation Procedures for Floating Socket

«Mating»

1. Place the floating socket at the tip on the receptacle mating point.

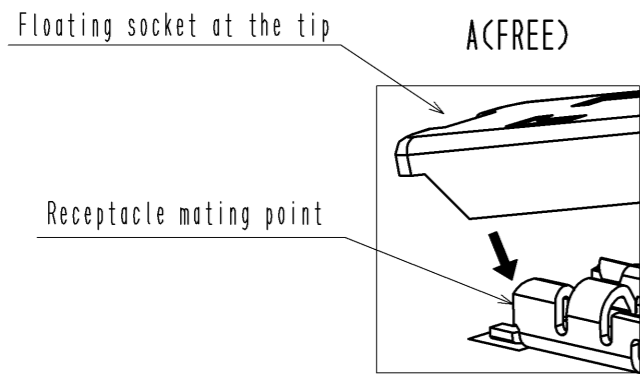
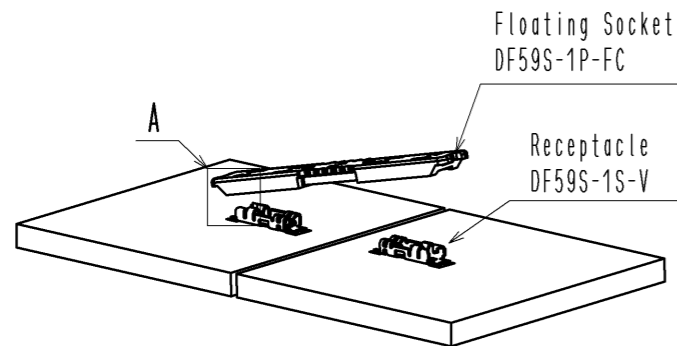

2. Align the center position of floating socket to the center position of the clearance between the facing PCBs in a line.

Press down at the center surface of the floating socket.

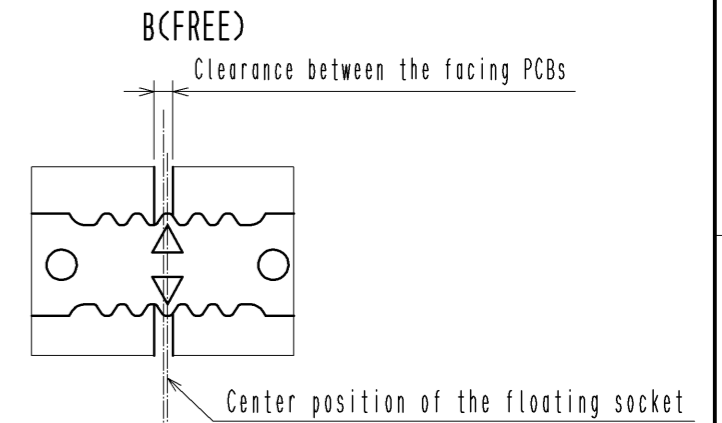
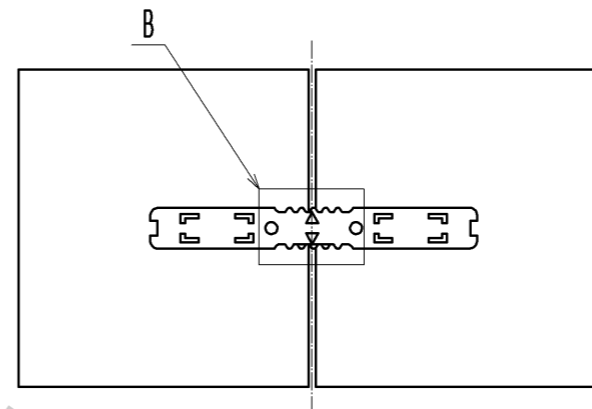

These center positions are in the same line.

※Floating socket can be mating both directions.

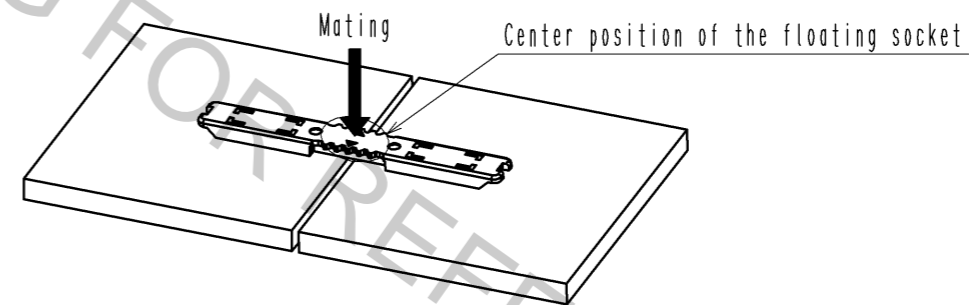
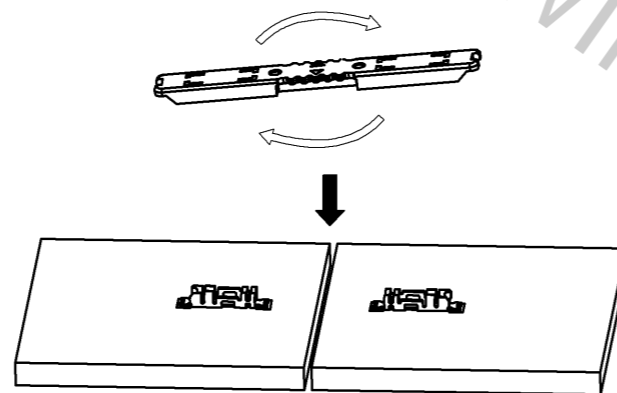

«Unmating»

1. Hook the lever on either sides of floating socket with finger and lift up to the upper direction for unlock. (Lift up until friction lock is released.)

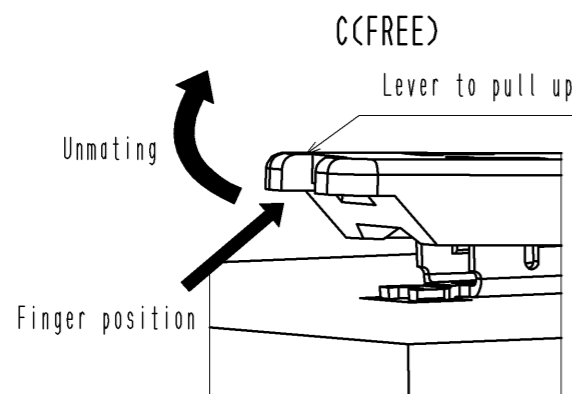
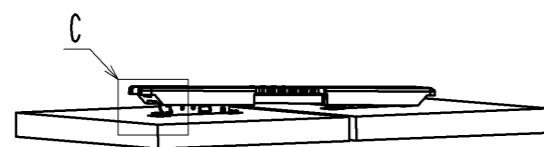

2. After releasing either side, hook the lever on the other side with a finger and lift up to the upper direction, too.

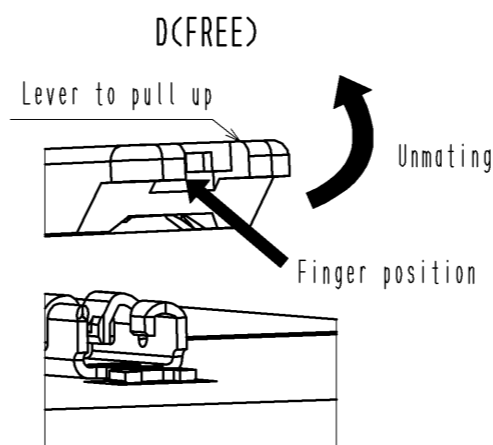
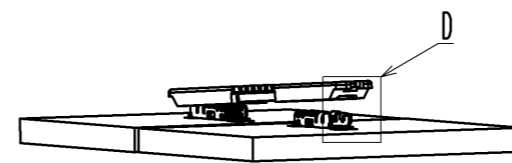

HRS	DRAWING NO.	EDC3-342886-03	3/4
	PART NO.	DF59S-1P-FC(24)	
	CODE NO.	CL667-0023-3-24	

DF59S Dimension of floating

The dimension of floating at the time of using a floating socket is shown below.
Please use in the limits of dimension.

《Direction of X axis》

The dimension of floating of X direction is shown below.

■ Direction of X axis floating: +0.5mm

■ Normal mating

■ Direction of X axis floating: -0.5mm

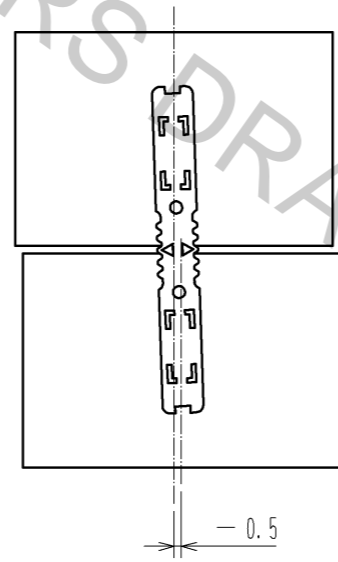
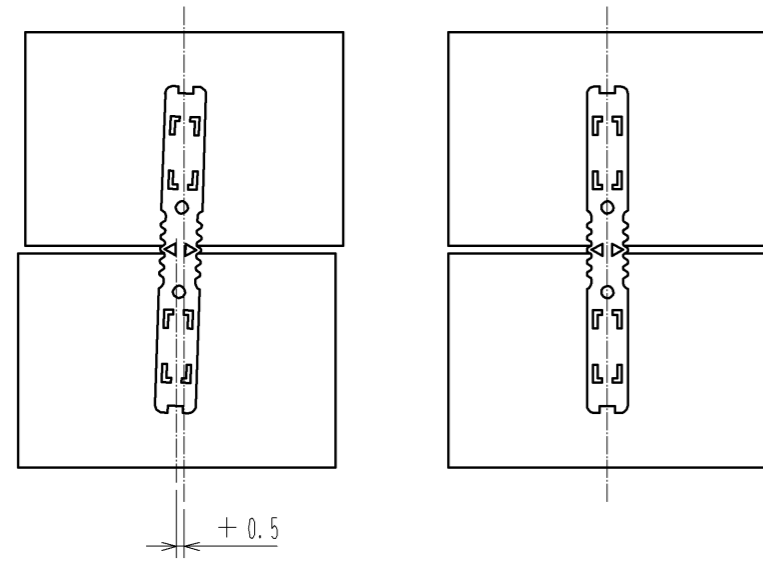

《Direction of Y axis》

The dimension of floating of Y direction is shown below.

■ Direction of Y axis floating: +0.5mm

■ Normal mating

■ Direction of Y axis floating: -0.5mm

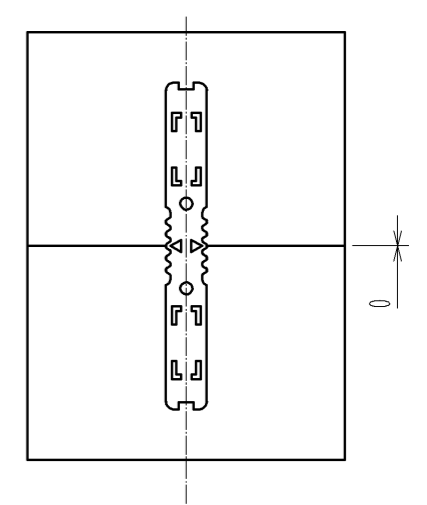
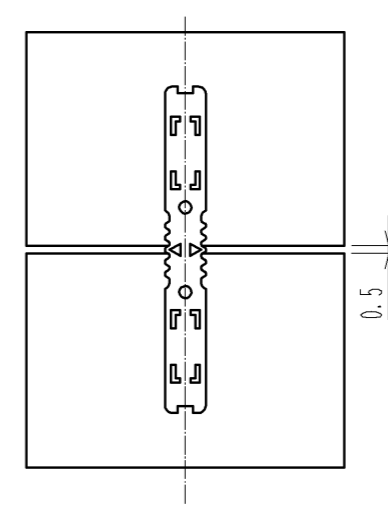
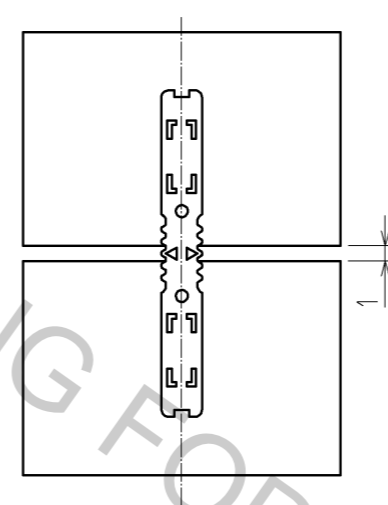

《Direction of Z axis》

The dimension of floating of Z direction is shown below.

■ Direction of Z axis floating: +0.2mm

■ Normal mating

■ Direction of Z axis floating: -0.2mm

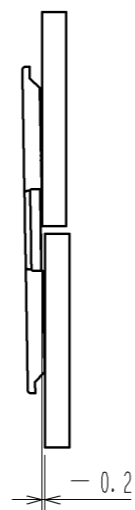
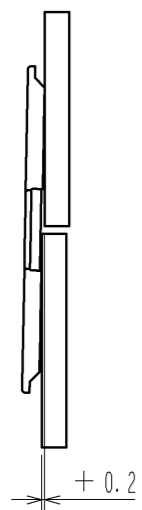

図番:	EDC3-342886-03
製品名:	DF59S-1P-FC(24)
製品コード:	CL667-0023-3-24