

# KMT32B Magnetic Angle Sensor

TDFN

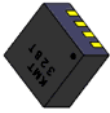

SO8

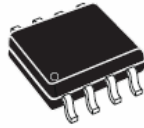

SM8



- AMR Sensor with 180° Period
- Moderate Field Strength
- High Accuracy
- TDFN Package
- Various Packages Available

## DESCRIPTION

The KMT32B is a magnetic field sensor based on the anisotropic magnetoresistance effect, i.e. it is sensing the **magnetic field direction** independently on the magnetic field strength for applied field strengths  $H > 25$  kA/m. The sensor contains two parallel supplied Wheatstone bridges, which enclose a sensitive angle of 45 degrees.

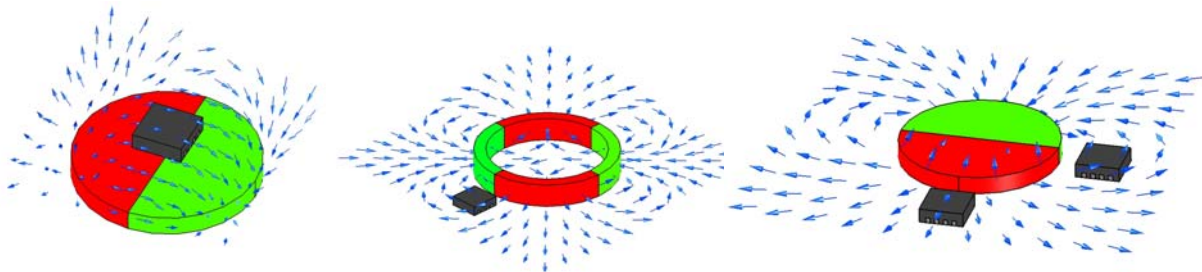

A rotating magnetic field in the surface parallel to the chip (x-y plane) will deliver two independent sinusoidal output signals, one following a  $\cos(2\alpha)$  and the second following a  $\sin(2\alpha)$  function,  $\alpha$  being the angle between sensor and field direction (see Figure 2).

## FEATURES

- Contactless Angular Position
- SMD Package
- Design Optimized Linearity
- Low Cost
- High Accuracy
- High Rotational Speed up to 30,000 rpm
- Extended Operating Temperature Range (-40 °C to +150 °C, +160°C on request)
- Low Power
- RoHS Compliant (lead free)
- Ideal for Harsh Environments due to Magnetic Sensing

## APPLICATIONS

- Absolute and Incremental Angle
- Angle Measurement
- Motor Motion Control
- Robotics
- Camera Positioning
- Potentiometer Replacement
- Automotive

# KMT32B Magnetic Angle Sensor

## CHARACTERISTIC VALUES

Parameter	Symbol	Condition	Min	Typ	Max	Unit
<b>A. Operating Limits</b>						
max. supply voltage	$V_{CC,max}$				10	V
max. current (single bridge)	$I_{CC,max}$				4	mA
operating temperature	$T_{op}$		-40		+150	°C
storage temperature	$T_{st}$		-40		+150	°C
<b>B. Sensor Specifications (T=25 °C)</b>						
Supply voltage	Vcc			5		V
Resistance (single bridge)	$R_b$		2400	3000	3600	$\Omega$
Output signal range	$\Delta V_n/V_{CC}$	Condition A, B	16	20		mV/V
Offset voltage	$V_{off}/V_{CC}$	Condition A, B	-1	0	+1	mV/V
angular inaccuracy	$\Delta\alpha$	Condition A, B		0.05	0.2	deg
angular hysteresis	$\Delta\alpha H$	Condition A, B			0.1	deg
<b>C. Sensor Specifications</b>						
TC of amplitude	TCSV	Condition A, C	-0.36	-0.32	-0.28	%/K
TC of resistance	TCBR	Condition A, C	+0.27	+0.32	+0.37	%/K
TC of offset	TCVoff	Condition A, C	-4	0	+4	$\mu V/V/K$

Stress above one or more of the limiting values may cause permanent damage to the device. Exposure to limiting values for extended periods may affect device reliability.

## MEASUREMENT CONDITIONS

Parameter	Symbol	Unit	Condition
<b>A. Set Up Conditions</b>			
ambient temperature	T	°C	T = 23±5 °C (unless otherwise noted)
supply voltage	Vcc	V	Vcc = 5 V
applied magnetic field	H	kA/m	H = 25 kA/m
<b>B. Sensor Specifications (T=25 °C, 360° turn , H=25 kA/m , <math>V_{Omax}&gt;0</math>, <math>V_{Omin}&lt;0</math>)</b>			
Output signal range	$\Delta V_n/V_{CC}$	mV/V	$\Delta V_n/V_{CC} = (V_{Omax} - V_{Omin})/V_{CC}$
Offset voltage	$V_{off}/V_{CC}$	mV/V	$V_{off} = (V_{Omax} + V_{Omin})/V_{CC}$
angular inaccuracy	$\Delta\alpha$	deg	$\Delta\alpha = MAX \alpha_0 - \alpha $ max. angular difference between actual value $\alpha_0$ and measured angle; offset voltage error contributions not included
angular hysteresis	$\Delta\alpha H$	deg	$\Delta\alpha H = MAX \alpha_{left\ turn} - \alpha_{right\ turn} $ max. angular difference between left and right turn

# KMT32B Magnetic Angle Sensor

## MEASUREMENT CONDITIONS

Parameter	Symbol	Unit	Condition
<b>C. Sensor Specifications (T=-25°C, +125°C)</b>			
ambient temperatures	T	°C	T <sub>1</sub> = -25 °C, T <sub>0</sub> = +25 °C, T <sub>2</sub> = +125 °C
TC of amplitude	TCSV	%/K	$TCV = \frac{1}{(T_2 - T_1)} \cdot \frac{\frac{\Delta V_n}{V_{cc}}(T_2) - \frac{\Delta V_n}{V_{cc}}(T_1)}{\frac{\Delta V_n}{V_{cc}}(T_1)} \cdot 100\%$
TC of resistance	TCSR	%/K	$TCR = \frac{1}{(T_2 - T_1)} \cdot \frac{R(T_2) - R(T_1)}{R(T_1)} \cdot 100\%$
TC of offset	TCVoff	µV/(VK)	$TCV_{off} = \frac{V_{off}(T_2) - V_{off}(T_1)}{(T_2 - T_1)}$

## BLOCK DIAGRAM

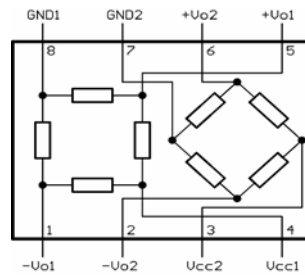

Figure 1: Circuit Diagram

The KMT32B magnetic field sensor is suited for high precision angle measurement applications under low field conditions (regularly H<sub>0</sub> = 25 kA/m, with reduced accuracy applicable down to H<sub>0</sub> = 8 kA/m; beware of earth's magnetic field!).

## TYPICAL PERFORMANCE CURVES

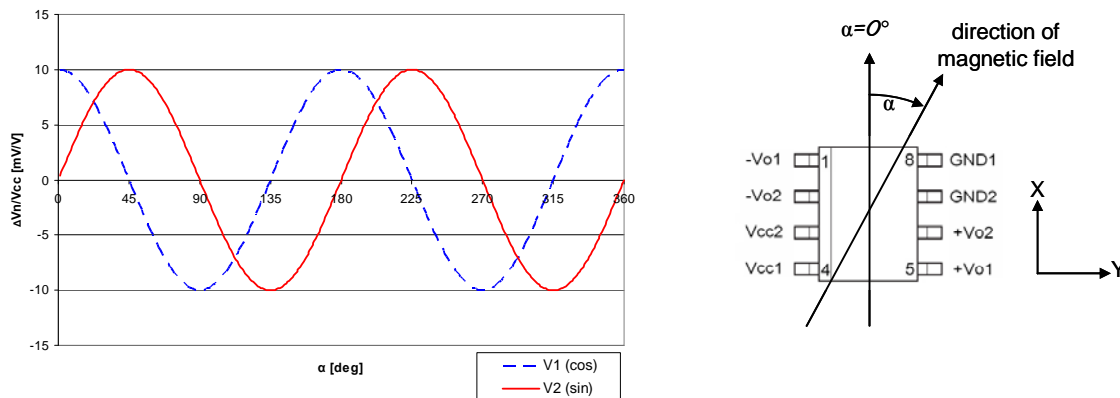
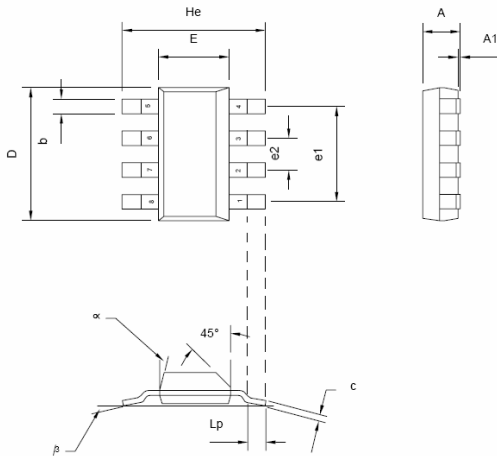

Figure 2: Characteristic curves for KMT32B

# KMT32B Magnetic Angle Sensor

## PACKAGES

### SM8



Dim	Millimetres			Inches		
	Min	Typ	Max	Min	Typ	Max
A	-	-	1.7	-	-	0.067
A1	0.02	-	0.1	0.0008	-	0.004
b	-	0.7	-	-	0.028	-
c	0.24	-	0.32	0.009	-	0.013
D	6.3	-	6.7	0.248	-	0.264
E	3.3	-	3.7	0.130	-	0.145
e1	-	4.59	-	-	0.180	-
e2	-	1.53	-	-	0.060	-
He	6.7	-	7.3	0.264	-	0.287
Lp	0.9	-	-	0.035	-	-
$\alpha$	-	-	15°	-	-	15°
$\beta$	-	10°	-	-	10°	-

### SO8

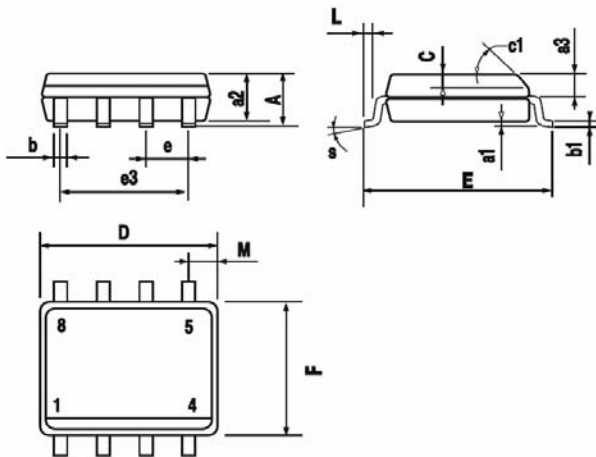

DIM.	mm			inch		
	MIN.	TYP.	MAX.	MIN.	TYP.	MAX.
A			1.75			0.069
a1	0.1		0.25	0.004		0.010
a2			1.65			0.065
a3	0.65		0.85	0.026		0.033
b	0.35		0.48	0.014		0.019
b1	0.19		0.25	0.007		0.010
C	0.25		0.5	0.010		0.020
c1	45° (typ.)					
D (1)	4.8		5.0	0.189		0.197
E	5.8		6.2	0.228		0.244
e		1.27			0.050	
e3		3.81			0.150	
F (1)	3.8		4.0	0.15		0.157
L	0.4		1.27	0.016		0.050
M			0.6			0.024
S	8° (max.)					

# KMT32B Magnetic Angle Sensor

## PACKAGES

### TDFN8

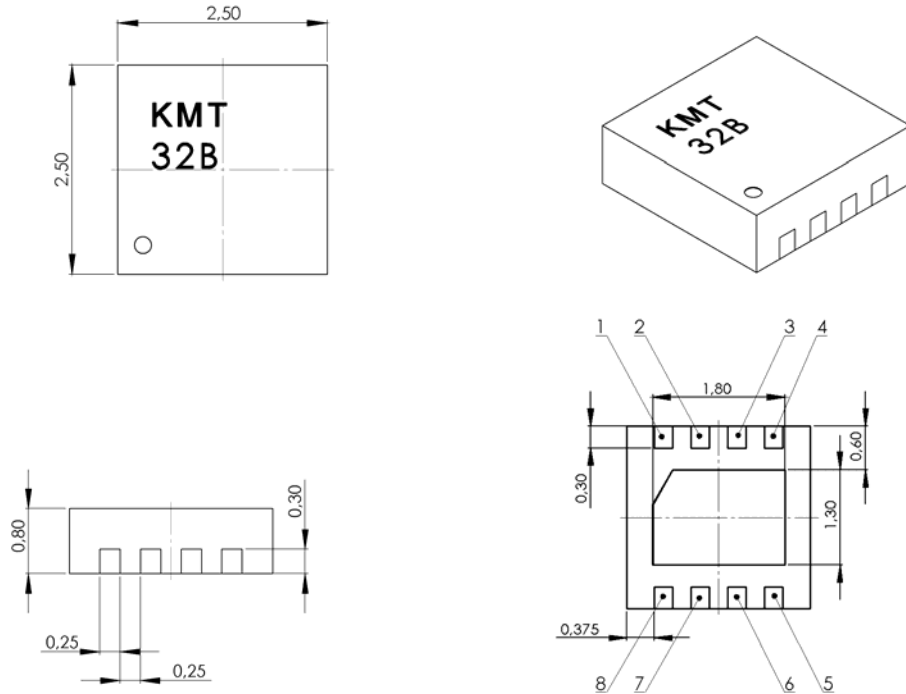

## DIE

unit:  $\mu\text{m}$

chipsize: app. 1480 x 1250

padsize: 120 x 120

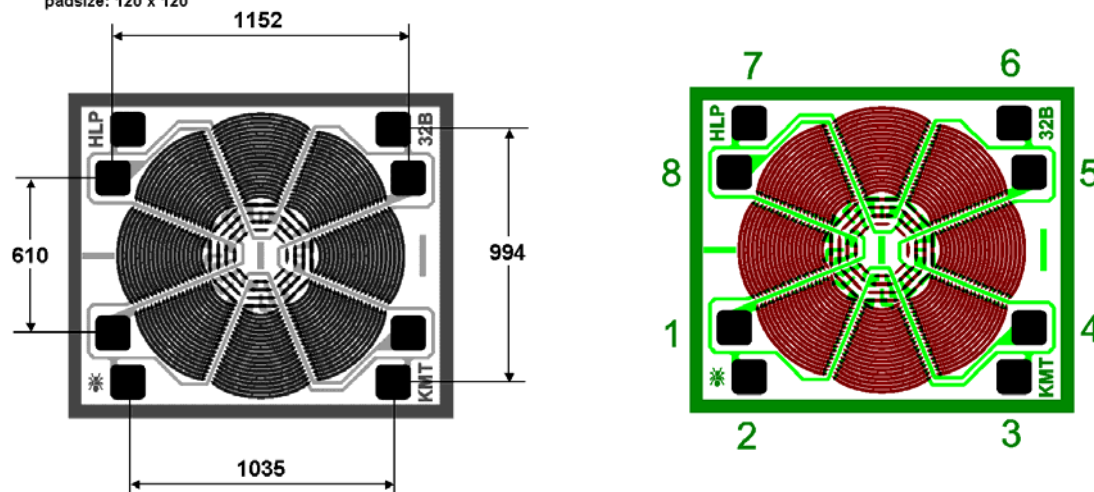

# KMT32B Magnetic Angle Sensor

## Pin assignment:

Pin	Symbol	Function
1	-Vo1	negative output Bridge 1
2	-Vo2	negative output Bridge 2
3	Vcc2	positive supply voltage Bridge 2
4	Vcc1	positive supply voltage Bridge 1
5	+Vo1	positive output Bridge 1
6	+Vo2	positive output Bridge 2
7	GND2	negative supply voltage Bridge 2
8	GND1	negative supply voltage Bridge 1

The bottom plate is designated to be a heat sink. It has no electrical connection to any pin.  
The sensitive area is positioned in the center of the housing.

## ORDERING CODE

Device	Package	Part Number
KMT32B/SM	SM8	G-MRCO-014
KMT32B/SO	SO8	G-MRCO-015
KMT32B/TD	TDFN8	G-MRCO-016
KMT32B	Die	G-MRCH-011

## ORDERING INFORMATION

### NORTH AMERICA

**Measurement Specialties, Inc.**  
1000 Lucas Way  
Hampton, VA 23666  
**Sales and Customer Service**  
Tel: +1-800-745-8008 or  
+1-757-766-1500  
Fax: +1-757-766-4297  
enduser@meas-spec.com

### EUROPE

**MEAS Deutschland GmbH**  
**HL Planartechnik**  
Hauert 13  
44227 Dortmund  
**Sales and Customer Service**  
Tel: +49 (0)231 / 9740-0  
Fax: +49 (0)231 / 9740-20  
info.de@meas-spec.com

### ASIA

**Measurement Specialties**  
**(China), Ltd.**  
F1.6-4D, Tian An  
Development Compound  
Shenzhen, China 518048  
**Sales and Customer Service**  
Tel: +86 755 8330 1004  
Fax: +86 755 8330 6797  
sale.china@meas-spec.com

The information in this sheet has been carefully reviewed and is believed to be accurate; however, no responsibility is assumed for inaccuracies. Furthermore, this information does not convey to the purchaser of such devices any license under the patent rights to the manufacturer. Measurement Specialties, Inc. reserves the right to make changes without further notice to any product herein. Measurement Specialties, Inc. makes no warranty, representation or guarantee regarding the suitability of its product for any particular purpose, nor does Measurement Specialties, Inc. assume any liability arising out of the application or use of any product or circuit and specifically disclaims any and all liability, including without limitation consequential or incidental damages. Typical parameters can and do vary in different applications. All operating parameters must be validated for each customer application by customer's technical experts. Measurement Specialties, Inc. does not convey any license under its patent rights nor the rights of others.