

THIS DRAWING IS UNPUBLISHED. RELEASED FOR PUBLICATION ,19 .  
 © COPYRIGHT 19 BY AMP INCORPORATED. ALL INTERNATIONAL RIGHTS RESERVED.

LOC		DIST		P		F		REVISIONS		DATE	APPD
G	14							ZONE	LTR	DESCRIPTION	
								C		REVISED PER 0L20-0220-97	02OCT97

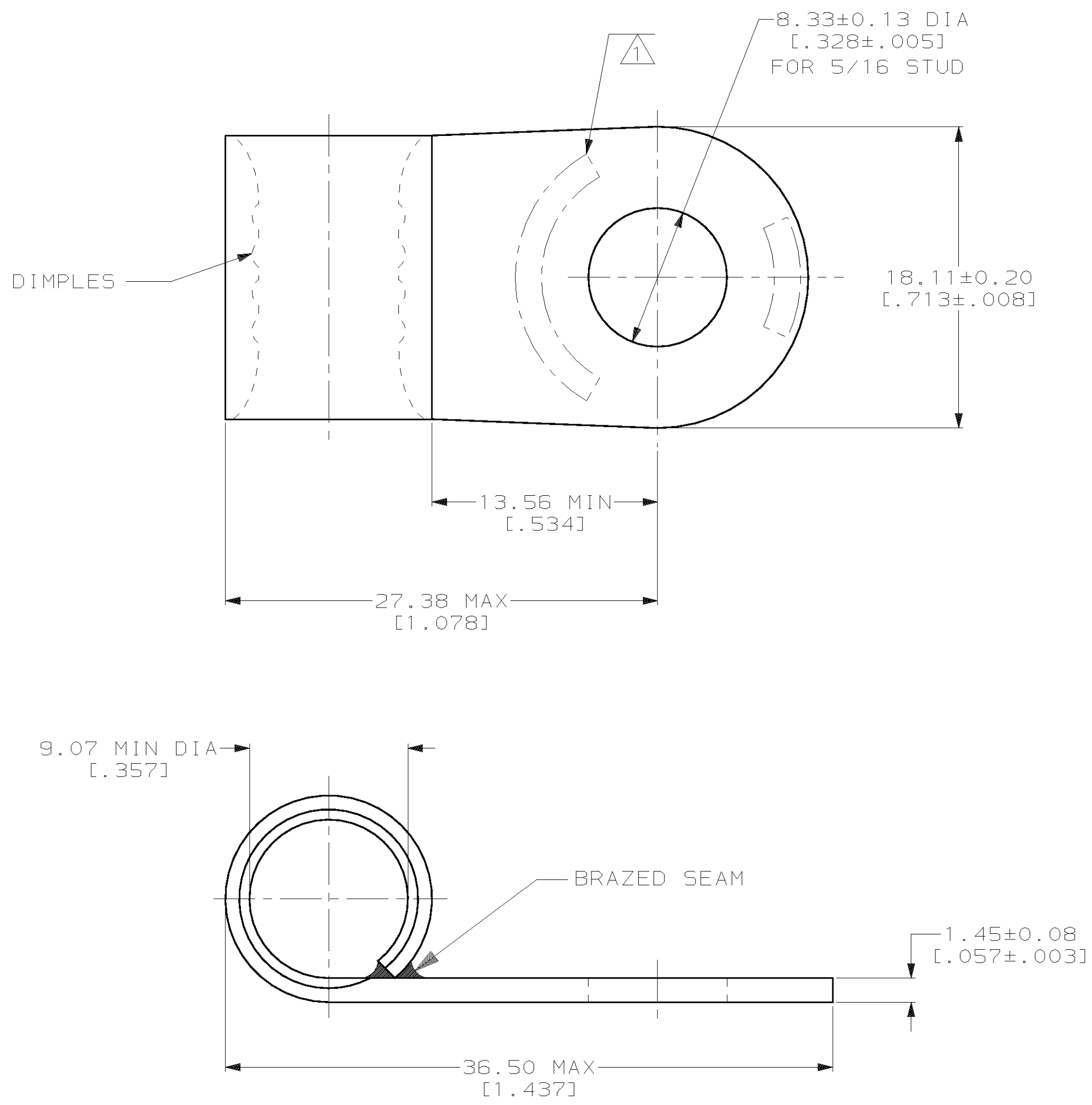

<b>AMP</b> WIRE RANGE	<b>UL</b> E13288 Listed
2 AWG SOLID OR STRANDED	2 AWG STRANDED
<b>SP</b> LR7189 Certified	MILITARY P/N AND CLASS
2 AWG SOLID OR STRANDED	NOT APPLICABLE

1 STAMP AMP 2W\* 60-75 APPROX AS SHOWN

<b>AMP INCORPORATED</b> CUSTOMER SERVICE SYSTEMS		MAX RECOMMENDED OPERATING TEMPERATURE: 170°C MAX	DO NOT SCALE PRINT. UNLESS SPECIFIED DIMENSIONS IN mm [INCHES] TOLERANCES ON: 2 PLC DEC ± - 3 PLC DEC ± - ANGLES ± -	DR 4-8-93 TA BRINKMAN	<b>AMP</b> AMP Incorporated Harrisburg, PA 17105-3608
FOR ADDITIONAL PRODUCT INFORMATION OR COPIES OF DRAWINGS AND TECHNICAL DOCUMENTS	PRODUCT INFORMATION CENTER 1-800-522-6752	VOLTAGE RATING: NOT APPLICABLE	MATERIAL COPPER PER ASTM B-152 ANNEALED	CHK 4-8-93 DA PATTERSON	
FOR APPLICATION TOOLING INFORMATION	TOOLING ASSISTANCE CENTER 1-800-722-1111	WIRE CROSS SECTIONAL AREA RANGE: 26.7-42.4mm <sup>2</sup> [52,600-83,700] CIR MILS SOLID OR STRANDED	FINISH TIN PLATE 0.00254 [0.000100] MIN THK PER ASTM B-545	APPD 4-8-93 DE MILLER	NAME TERMINAL, RING TONGUE, FLAG, SOLISTRAND™
FOR ORDER ENTRY	1-800-526-5142	THIS DRAWING IS A CONTROLLED DOCUMENT FOR AMP INCORPORATED. IT IS SUBJECT TO CHANGE AND THE CONTROLLING ENGINEERING ORGANIZATION SHOULD BE CONTACTED FOR THE LATEST REVISION.		APPD 4-8-93 JL MECKLEY	SIZE C 00779
				PRODUCT SPEC -	DRAWING NO C-321064
				APPLICATION SPEC -	SCALE 4:1
				WEIGHT -	SHEET 1 OF 1