

Apr.1.2017 Copyright 2017 HIROSE ELECTRIC CO., LTD. All Rights Reserved.

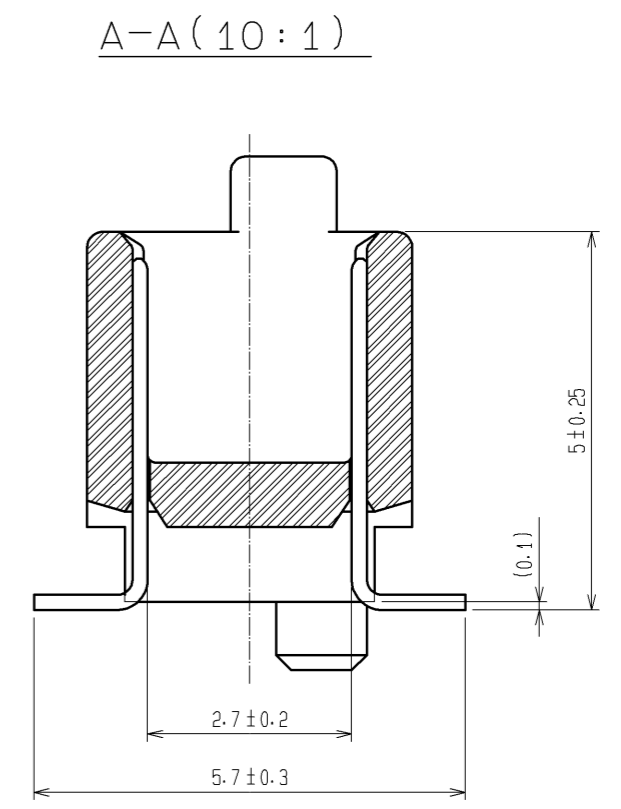

RECOMMENDED LAND PATTERN DIMENSION OF PCB (MOUNTING SIDE)  
(RECOMMENDED METAL MASK THICKNESS t=0.15)

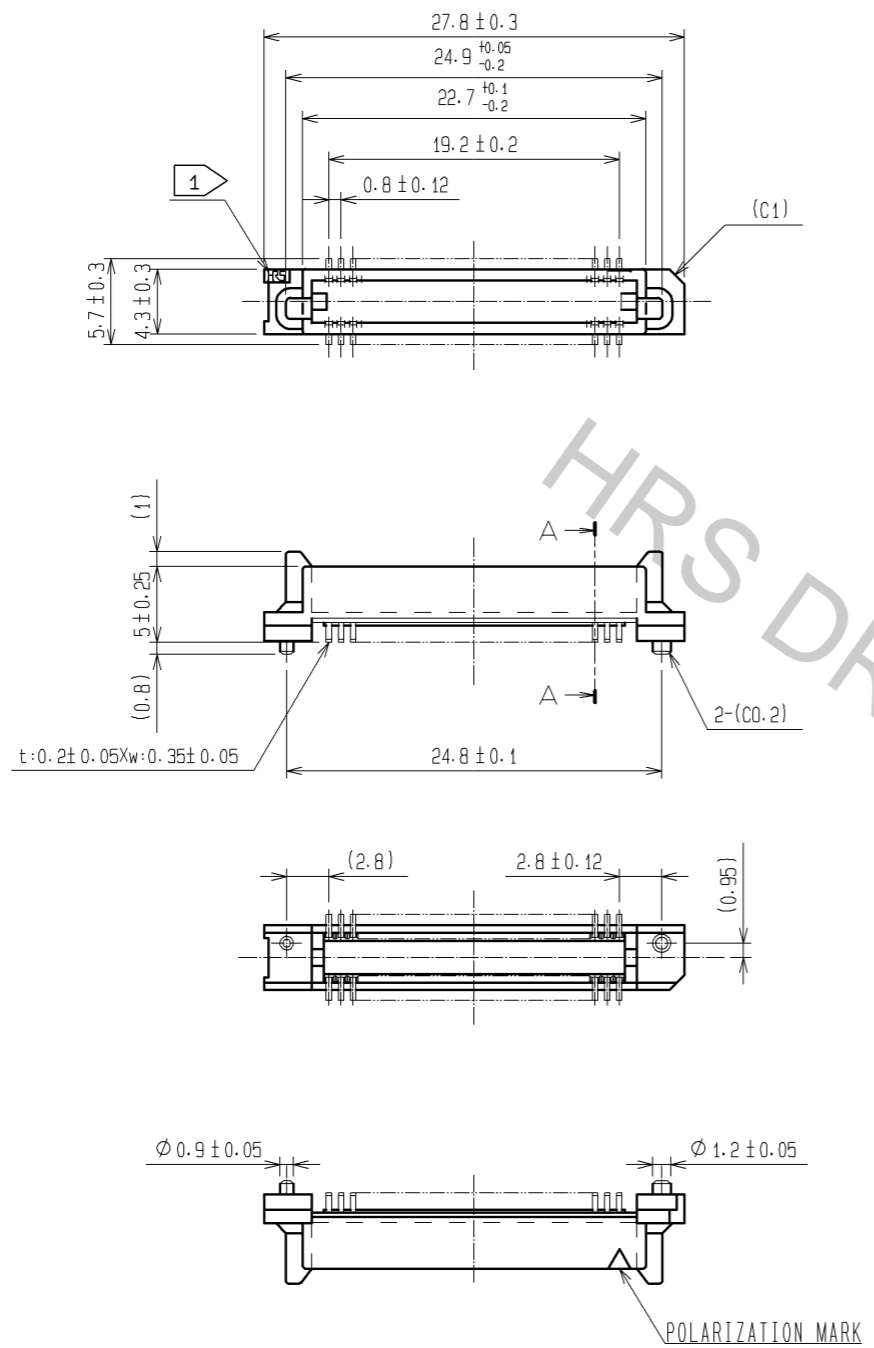
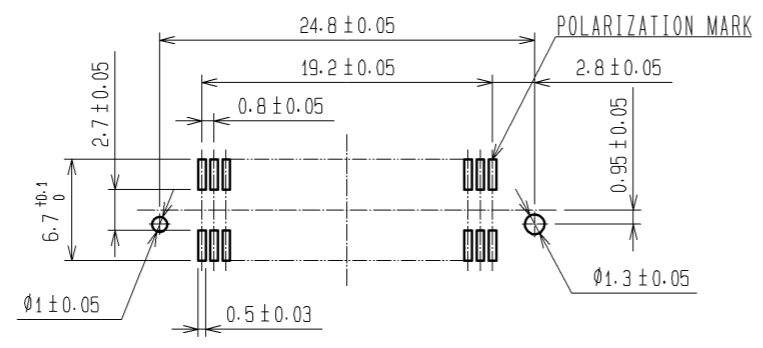

- NOTES
1. HRS MARK SHOULD BE OPTIONAL.
  2. LEAD CO-PLANARITY SHALL BE 0.1mm MAX.
  3. FOR MODIFICATION, ETC., PREVENTIVE HOLE FOR SINK MARK MAY BE ADDED ACCORDING TO CIRCUMSTANCES.
  4. THE DIMENSIONS IN PARENTHESES ARE FOR REFERENCE.

1	PPS	LIGHT BROWN UL94V-0	2	PHOSPHOR BRONZE	CONTACT AREA:GOLD 0.1μm min. LEAD AREA:TIN-PLATING 1μm min. UNDER PLATING:NICKEL 1μm min.		
NO.	MATERIAL	FINISH . REMARKS	NO.	MATERIAL	FINISH . REMARKS		
UNITS mm		SCALE 2 : 1	COUNT △	DESCRIPTION OF REVISIONS	DESIGNED	CHECKED	DATE
<b>HRS</b> HIROSE ELECTRIC CO., LTD.		APPROVED : HS. OKAWA	08.06.26	DRAWING NO.	EDC3-071638-25		
		CHECED : HT. YAMAGUCHI	08.06.25	PART NO.	FX6-50P-0.8SV1(C71)		
		DESIGNED : SY. KAMIGA	08.06.23	CODE NO.	CL576-0024-9-71		
		DRAWN : TP. MATSUMOTO	08.06.18		△ 1/1		