

TPA IN CLOSED (AS SHIPPED) POSITION

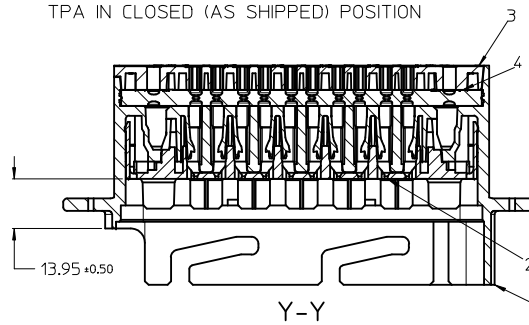

NOTES:

1. MATERIALS:  
HOUSINGS: SPS/NYLON BLEND, GLASS FILLED, UL 94 HB  
SEAL: SILICONE RUBBER
2. MX150 BLADE TERMINALS PER SD-33000-001 TO BE USED WITH THIS ASSEMBLY IN CAVITIES B, C, D, E AND F CRIMPED WITH CABLE INSULATION OUTER DIAMETER IN THE RANGE 1.5mm TO 2.7mm
3. MX150L BLADE TERMINALS PER SD-19431-00\* TO BE USED WITH THIS ASSEMBLY IN CAVITIES A AND G CRIMPED WITH CABLE INSULATION OUTER DIAMETER IN THE RANGE 3.0mm TO 5.0mm
4. PRODUCT SPECIFICATION: PS-85083-001
5. PACKAGING SPECIFICATION: PK-85071-001
6. MATES WITH: SRC 60+6AG POWER RECEPTACLE HOUSING ASSEMBLY PART NUMBER 850840700 PER SD-85084-700
7. APPLICATION SPECIFICATION: AS-85083-001
8. FLANGE GASKET OPTIONS: REFER TO SD-85071-016

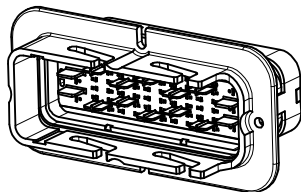

| No. | DESCRIPTION      | QTY. | COLOUR   |
|-----|------------------|------|----------|
| 4   | MALE BACK SEAL   | 1    | RUST RED |
| 3   | MALE REAR COVER  | 1    | BLACK    |
| 2   | MALE FRONT COVER | 1    | GREEN    |
| 1   | MALE HOUSING     | 1    | BLACK    |

BILL OF MATERIAL

RECOMMENDED PANEL CUTOUT DIMENSIONS

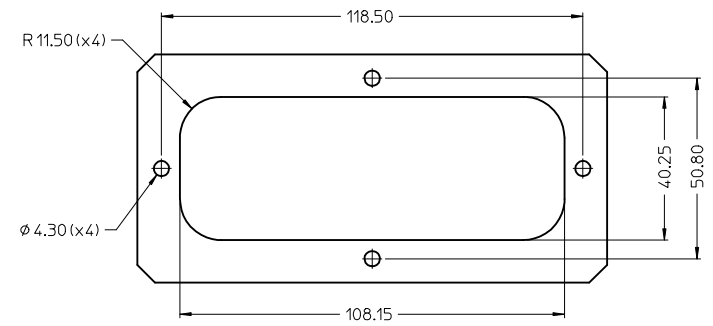

TPA IN PRE-LOAD POSITION

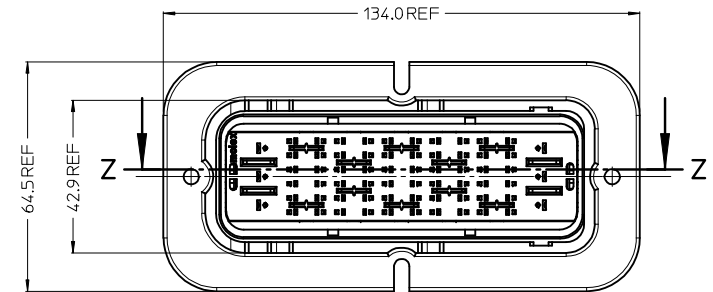
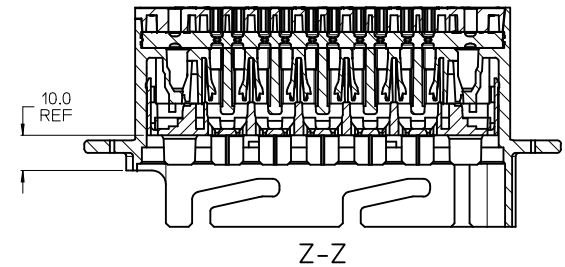

|  |                               |   |  |   |                                     |   |                        |  |  |
|--|-------------------------------|---|--|---|-------------------------------------|---|------------------------|--|--|
| <b>ADD SHEETS 2,688</b><br>EC NO: PG2015-0070<br>DRWN: J WALLACE 2013/12/17<br>CHKD: SMC GREVY 2014/07/18<br>APPR: F DUGGAN 2014/07/21 | QUALITY SYMBOLS<br>▽=0<br>▽=0 | GENERAL TOLERANCES (UNLESS SPECIFIED)   |  | DIMENSION STYLE<br><b>MM ONLY</b>   | SCALE<br><b>1:1</b>                 | DESIGN UNITS<br><b>METRIC</b>                               | THIRD ANGLE PROJECTION |  |  |
|  |                               | 4 PLACES ± --- + ---<br>3 PLACES ± --- + ---<br>2 PLACES ± 0.20 + ---<br>1 PLACE ± 0.5 + ---<br>0 PLACE ± --- + --- | mm INCH<br>± --- ± ---<br>± 0.20 ± ---<br>± 0.5 ± ---<br>± --- ± --- | DRAWN BY<br>TVOGT   | DATE<br>2009/03/26                  | TITLE<br><b>SRC MIXED POWER MALE BLADE HOUSING ASSEMBLY</b> |                        |  |  |
|  |                               |   |  | CHECKED BY<br>RSILLER   | DATE<br>2009/03/30                  |   |                        |  |  |
|  |                               |   |  | APPROVED BY<br>AVOGT  | DATE<br>2009/03/31                  |   |                        |  |  |
|  |                               | ANGULAR ± .5 °  |  | MATERIAL NO.<br><b>850830300</b>  | DOCUMENT NO.<br><b>SD-85083-300</b> | SHEET NO.<br><b>1 OF 8</b>                                  |                        |  |  |
|  |                               | DRAFT WHERE APPLICABLE MUST REMAIN WITHIN DIMENSIONS  |  | THIS DRAWING CONTAINS INFORMATION THAT IS PROPRIETARY TO MOLEX INCORPORATED AND SHOULD NOT BE USED WITHOUT WRITTEN PERMISSION |                                     |   |                        |  |  |

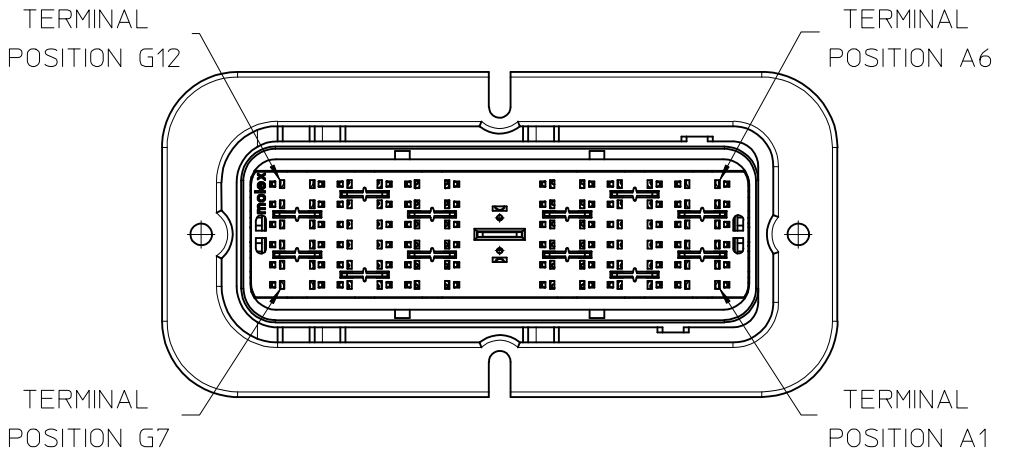
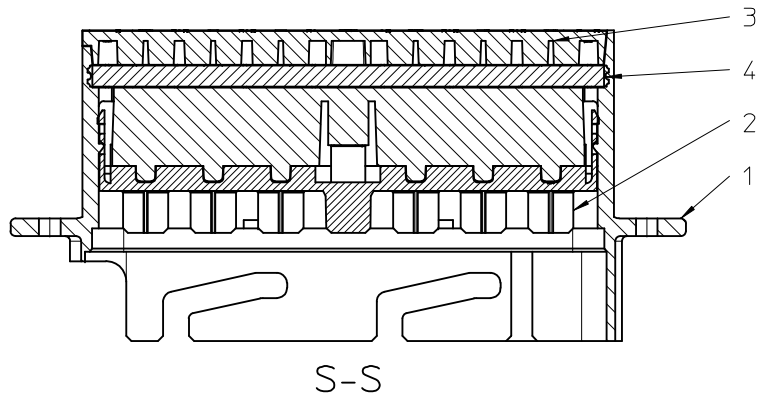

|                  |                  |      |          |
|------------------|------------------|------|----------|
| 4                | MALE BACK SEAL   | 1    | RUST RED |
| 3                | MALE REAR COVER  | 1    | BLACK    |
| 2                | MALE FRONT COVER | 1    | GREEN    |
| 1                | MALE HOUSING     | 1    | BLACK    |
| No.              | DESCRIPTION      | QTY. | COLOUR   |
| BILL OF MATERIAL |                  |      |          |

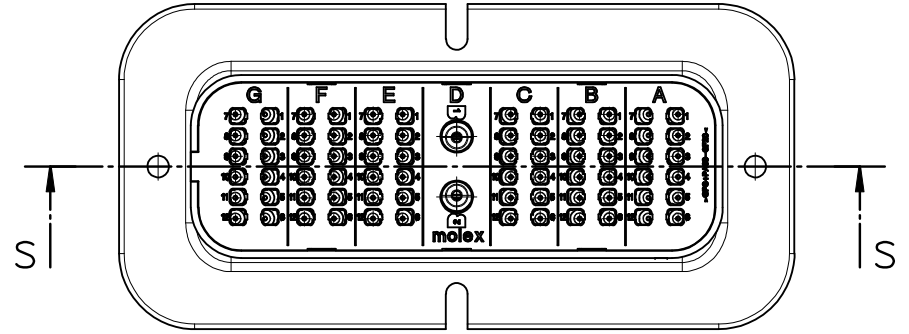

NOTES:

1. REFERENCE SHEET 1 FOR UNSPECIFIED NOTES AND DIMENSIONS
2. MX150 BLADE TERMINALS PER SD-33000-001 TO BE USED WITH THIS ASSEMBLY IN CAVITIES A, B, C, E, F AND G CRIMPED WITH CABLE INSULATION OUTER DIAMETER IN THE RANGE 1.5mm TO 2.7mm
3. MX150L BLADE TERMINALS PER SD-19431-00\* TO BE USED WITH THIS ASSEMBLY IN CAVITY D CRIMPED WITH CABLE INSULATION OUTER DIAMETER IN THE RANGE 3.0mm TO 5.0mm
4. MATES WITH: SRC 72+2D POWER RECEPTACLE HOUSING ASSEMBLY PART NUMBER 850847202 PER SD-85084-700

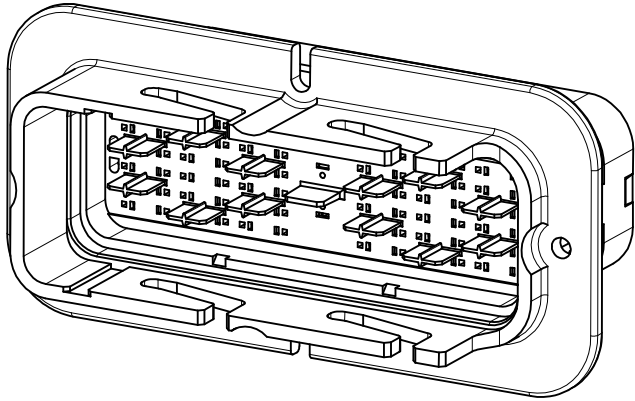

|   |                 |   |   |                                       |  |                        |  |
|---|-----------------|---|---|---------------------------------------|--|------------------------|--|
| SEE SHEET ONE<br>EC NO: IPG2015-0070<br>DRWN: J WALLACE 2013/12/17<br>CHKD: SMC GREVY 2014/07/18<br>APPR: F DUGGAN 2014/10/12 | QUALITY SYMBOLS | GENERAL TOLERANCES (UNLESS SPECIFIED)   | DIMENSION STYLE   | SCALE                                 | DESIGN UNITS   | THIRD ANGLE PROJECTION |  |
|   | ▽=0<br>∇=0      | mm INCH   | MM ONLY   | 1:1                                   | METRIC   |                        |  |
|   |                 | 4 PLACES ± --- ± ---<br>3 PLACES ± --- ± ---<br>2 PLACES ± 0.20 ± ---<br>1 PLACE ± 0.5 ± ---<br>0 PLACE ± --- ± --- | DRAWN BY DATE<br>TVOGT 2009/03/26   | CHECKED BY DATE<br>RSILLER 2009/03/30 | TITLE<br>SRC MIXED POWER MALE BLADE HOUSING ASSEMBLY |                        |  |
|   |                 | ANGULAR ± .5 °<br>DRAFT WHERE APPLICABLE MUST REMAIN WITHIN DIMENSIONS  | APPROVED BY DATE<br>AVOGT 2009/03/31  | MATERIAL NO.<br>850837202             | DOCUMENT NO.<br>SD-85083-300                         | SHEET NO.<br>2 OF 8    |  |
|   |                 |   | THIS DRAWING CONTAINS INFORMATION THAT IS PROPRIETARY TO MOLEX INCORPORATED AND SHOULD NOT BE USED WITHOUT WRITTEN PERMISSION |                                       |  |                        |  |

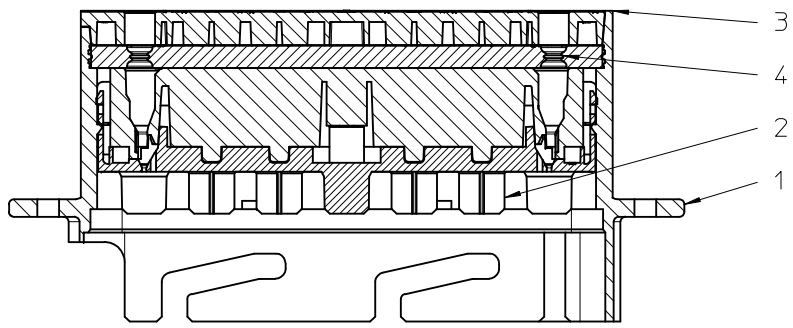

T-T

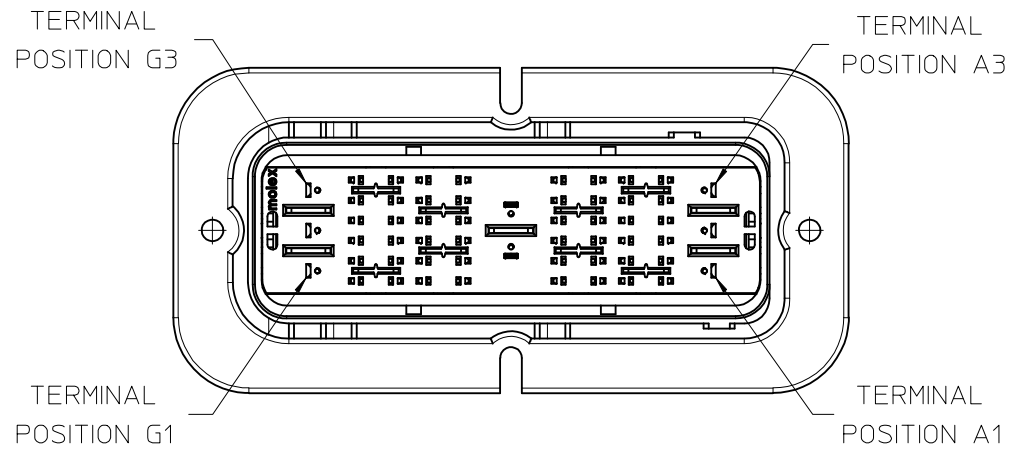

|     |                  |      |          |
|-----|------------------|------|----------|
| 4   | MALE BACK SEAL   | 1    | RUST RED |
| 3   | MALE REAR COVER  | 1    | BLACK    |
| 2   | MALE FRONT COVER | 1    | GREEN    |
| 1   | MALE HOUSING     | 1    | BLACK    |
| No. | DESCRIPTION      | QTY. | COLOUR   |

BILL OF MATERIAL

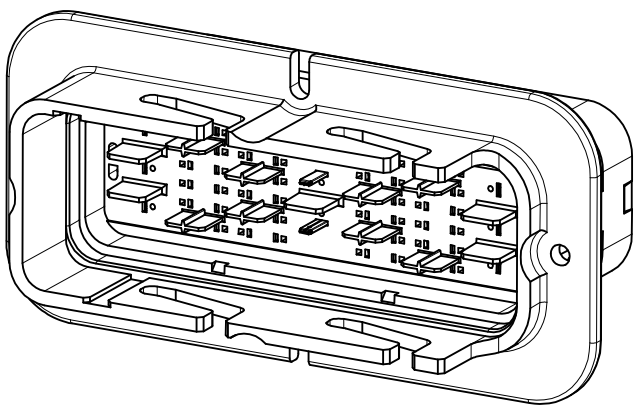
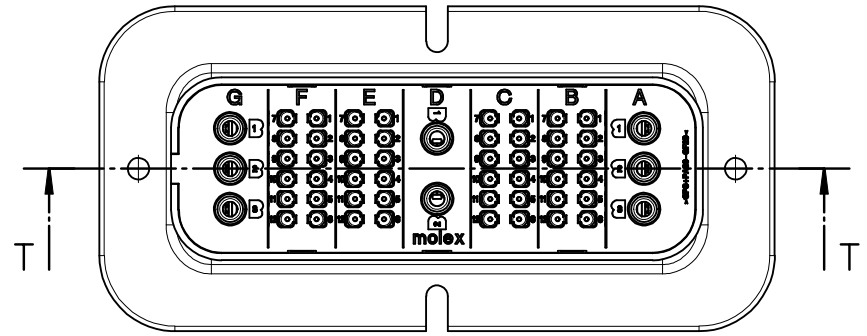

NOTES:

1. REFERENCE SHEET 1 FOR UNSPECIFIED NOTES AND DIMENSIONS
2. MX150 BLADE TERMINALS PER SD-33000-001 TO BE USED WITH THIS ASSEMBLY IN CAVITIES B, C, E AND F CRIMPED WITH CABLE INSULATION OUTER DIAMETER IN THE RANGE 1.5mm TO 2.7mm
3. MX150L BLADE TERMINALS PER SD-19431-00\* TO BE USED WITH THIS ASSEMBLY IN CAVITIES A, D AND G, CRIMPED WITH CABLE INSULATION OUTER DIAMETER IN THE RANGE 3.0mm TO 5.0mm
4. MATES WITH: SRC 48+8ADG POWER RECEPTACLE HOUSING ASSEMBLY PART NUMBER 850844808 PER SD-85084-700

|  |                               |   |                                     |                            |      |          |       |       |          |       |       |          |        |       |         |       |       |         |       |       |                                   |                     |                               |                        |
|--|-------------------------------|---|-------------------------------------|----------------------------|------|----------|-------|-------|----------|-------|-------|----------|--------|-------|---------|-------|-------|---------|-------|-------|-----------------------------------|---------------------|-------------------------------|------------------------|
| SEE SHEET ONE<br>EC NO: IPG2015-0070<br>DRWN: J WALLACE 2013/12/17<br>CHKD: SMCREEVY 2014/07/18<br>APPR: F DUGGAN 2014/10/21 | QUALITY SYMBOLS<br>▽=0<br>◻=0 | GENERAL TOLERANCES (UNLESS SPECIFIED)<br><table border="1"> <tr> <td></td> <td>mm</td> <td>INCH</td> </tr> <tr> <td>4 PLACES</td> <td>± ---</td> <td>± ---</td> </tr> <tr> <td>3 PLACES</td> <td>± ---</td> <td>± ---</td> </tr> <tr> <td>2 PLACES</td> <td>± 0.20</td> <td>± ---</td> </tr> <tr> <td>1 PLACE</td> <td>± 0.5</td> <td>± ---</td> </tr> <tr> <td>0 PLACE</td> <td>± ---</td> <td>± ---</td> </tr> </table> |                                     | mm                         | INCH | 4 PLACES | ± --- | ± --- | 3 PLACES | ± --- | ± --- | 2 PLACES | ± 0.20 | ± --- | 1 PLACE | ± 0.5 | ± --- | 0 PLACE | ± --- | ± --- | DIMENSION STYLE<br><b>MM ONLY</b> | SCALE<br><b>1:1</b> | DESIGN UNITS<br><b>METRIC</b> | THIRD ANGLE PROJECTION |
|  |                               | mm  | INCH                                |                            |      |          |       |       |          |       |       |          |        |       |         |       |       |         |       |       |                                   |                     |                               |                        |
|  | 4 PLACES                      | ± ---   | ± ---                               |                            |      |          |       |       |          |       |       |          |        |       |         |       |       |         |       |       |                                   |                     |                               |                        |
|  | 3 PLACES                      | ± ---   | ± ---                               |                            |      |          |       |       |          |       |       |          |        |       |         |       |       |         |       |       |                                   |                     |                               |                        |
| 2 PLACES   | ± 0.20                        | ± ---   |                                     |                            |      |          |       |       |          |       |       |          |        |       |         |       |       |         |       |       |                                   |                     |                               |                        |
| 1 PLACE  | ± 0.5                         | ± ---   |                                     |                            |      |          |       |       |          |       |       |          |        |       |         |       |       |         |       |       |                                   |                     |                               |                        |
| 0 PLACE  | ± ---                         | ± ---   |                                     |                            |      |          |       |       |          |       |       |          |        |       |         |       |       |         |       |       |                                   |                     |                               |                        |
| DRAWN BY<br>TVOGT  | DATE<br>2009/03/26            | TITLE<br><b>SRC MIXED POWER MALE BLADE HOUSING ASSEMBLY</b>   |                                     |                            |      |          |       |       |          |       |       |          |        |       |         |       |       |         |       |       |                                   |                     |                               |                        |
| CHECKED BY<br>RSILLER  | DATE<br>2009/03/30            | <b>molex</b>  |                                     |                            |      |          |       |       |          |       |       |          |        |       |         |       |       |         |       |       |                                   |                     |                               |                        |
| APPROVED BY<br>AVOGT   | DATE<br>2009/03/31            | MATERIAL NO.<br><b>850834808</b>  | DOCUMENT NO.<br><b>SD-85083-300</b> | SHEET NO.<br><b>3 OF 8</b> |      |          |       |       |          |       |       |          |        |       |         |       |       |         |       |       |                                   |                     |                               |                        |

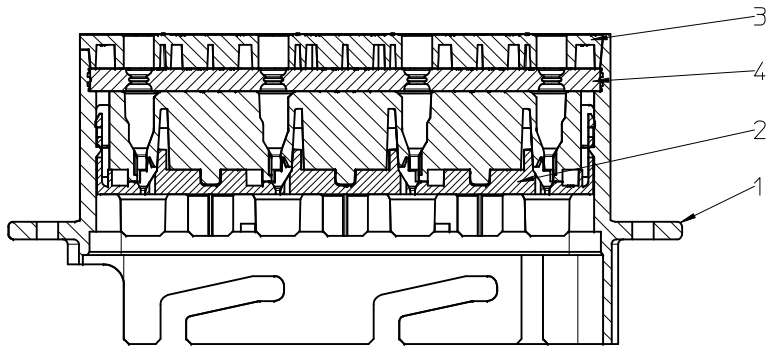

W-W

|                  |                  |      |          |
|------------------|------------------|------|----------|
| 4                | MALE BACK SEAL   | 1    | RUST RED |
| 3                | MALE REAR COVER  | 1    | BLACK    |
| 2                | MALE FRONT COVER | 1    | GREEN    |
| 1                | MALE HOUSING     | 1    | BLACK    |
| No.              | DESCRIPTION      | QTY. | COLOUR   |
| BILL OF MATERIAL |                  |      |          |

TERMINAL POSITION G3

TERMINAL POSITION A3

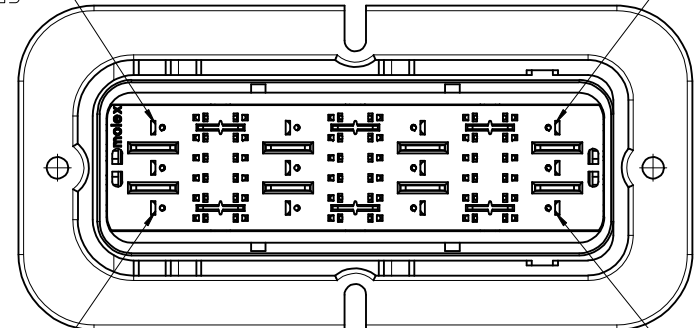

TERMINAL POSITION G1

TERMINAL POSITION A1

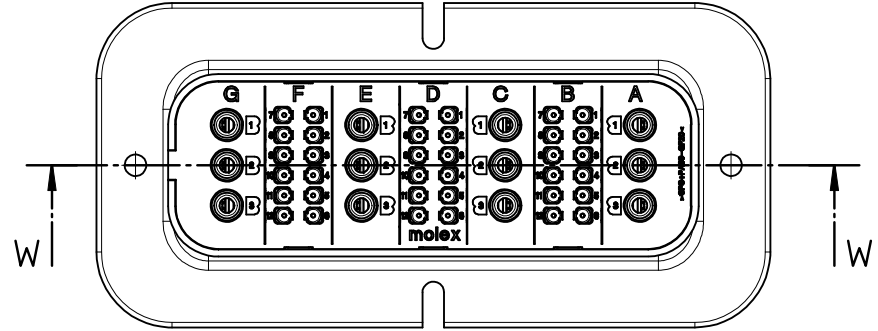

NOTES:

1. REFERENCE SHEET 1 FOR UNSPECIFIED NOTES AND DIMENSIONS
2. MX150 BLADE TERMINALS PER SD-33000-001 TO BE USED WITH THIS ASSEMBLY IN CAVITIES B, D AND F CRIMPED WITH CABLE INSULATION OUTER DIAMETER IN THE RANGE 1.5mm TO 2.7mm
3. MX150L BLADE TERMINALS PER SD-19431-00\* TO BE USED WITH THIS ASSEMBLY IN CAVITIES A, C, E AND G, CRIMPED WITH CABLE INSULATION OUTER DIAMETER IN THE RANGE 3.0mm TO 5.0mm
4. MATES WITH: SRC 36+12ACEG POWER RECEPTACLE HOUSING ASSEMBLY PART NUMBER 850843612 PER SD-85084-700

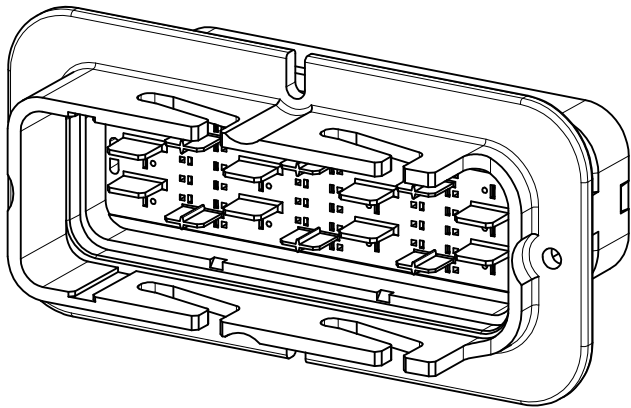

|  |                     |  |                      |                            |                    |   |                        |                        |
|--|---------------------|--|----------------------|----------------------------|--------------------|---|------------------------|------------------------|
| SEE SHEET ONE<br>EC NO: IPG2015-0070<br>DRWN: J WALLACE 2013/12/17<br>CHKD: SMC GREEVY 2014/07/18<br>APPR: F DUGGAN 2014/07/21 | QUALITY SYMBOLS     | GENERAL TOLERANCES (UNLESS SPECIFIED)                |                      | DIMENSION STYLE<br>MM ONLY |                    | SCALE<br>1:1  | DESIGN UNITS<br>METRIC | THIRD ANGLE PROJECTION |
|  | ▽=0<br>◻=0          | mm   | INCH                 | DRAWN BY<br>TVOGT          | DATE<br>2009/03/26 | TITLE<br>SRC MIXED POWER MALE BLADE HOUSING ASSEMBLY  |                        |                        |
|  |                     | 4 PLACES ± --- ± ---                                 | 3 PLACES ± --- ± --- | CHECKED BY<br>RSILLER      | DATE<br>2009/03/30 | molex<br>DOCUMENT NO.<br>SD-85083-300   |                        |                        |
|  |                     | 2 PLACES ± 0.20 ± ---                                | 1 PLACE ± 0.5 ± ---  | APPROVED BY<br>AVOGT       | DATE<br>2009/03/31 |   |                        |                        |
|  | 0 PLACE ± --- ± --- | ANGULAR ± .5 °                                       |                      | MATERIAL NO.<br>850833612  |                    | THIS DRAWING CONTAINS INFORMATION THAT IS PROPRIETARY TO MOLEX INCORPORATED AND SHOULD NOT BE USED WITHOUT WRITTEN PERMISSION |                        |                        |
|  |                     | DRAFT WHERE APPLICABLE MUST REMAIN WITHIN DIMENSIONS |                      | SIZE<br>A3                 |                    |   |                        |                        |

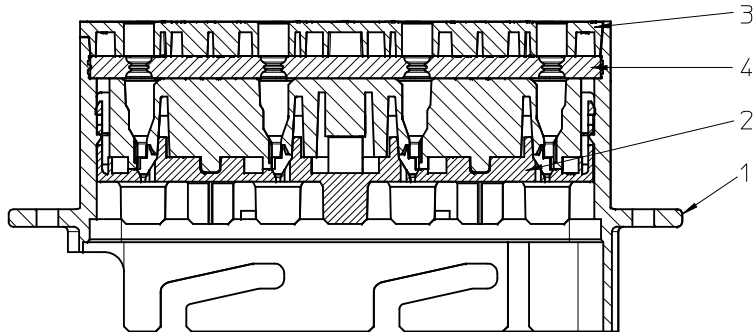

V-V

| 4                | MALE BACK SEAL   | 1    | RUST RED |
|------------------|------------------|------|----------|
| 3                | MALE REAR COVER  | 1    | BLACK    |
| 2                | MALE FRONT COVER | 1    | GREEN    |
| 1                | MALE HOUSING     | 1    | BLACK    |
| No.              | DESCRIPTION      | QTY. | COLOUR   |
| BILL OF MATERIAL |                  |      |          |

TERMINAL POSITION G3

TERMINAL POSITION A3

TERMINAL POSITION G1

TERMINAL POSITION A1

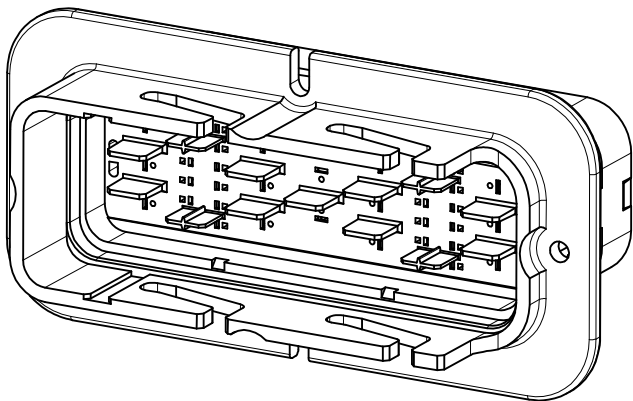
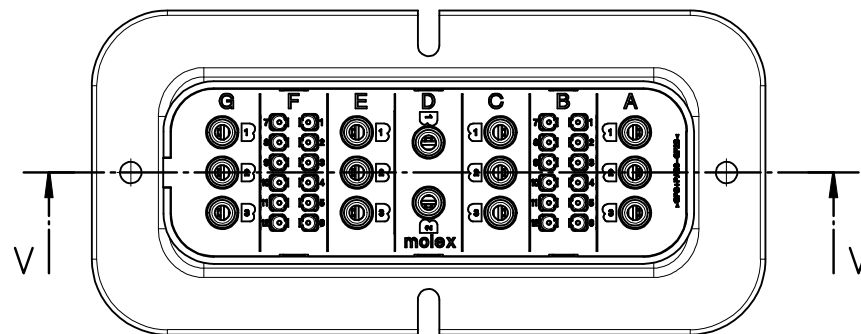

NOTES:

1. REFERENCE SHEET 1 FOR UNSPECIFIED NOTES AND DIMENSIONS
2. MX150 BLADE TERMINALS PER SD-33000-001 TO BE USED WITH THIS ASSEMBLY IN CAVITIES B AND F CRIMPED WITH CABLE INSULATION OUTER DIAMETER IN THE RANGE 1.5mm TO 2.7mm
3. MX150L BLADE TERMINALS PER SD-19431-00\* TO BE USED WITH THIS ASSEMBLY IN CAVITIES A, C, D, E AND G, CRIMPED WITH CABLE INSULATION OUTER DIAMETER IN THE RANGE 3.0mm TO 5.0mm
4. MATES WITH: SRC 24+14ACDEG POWER RECEPTACLE HOUSING ASSEMBLY PART NUMBER 850842414 PER SD-85084-700

|  |  |  |                                     |                     |                        |                        |       |       |          |       |       |          |        |       |         |       |       |         |       |       |   |          |      |       |            |            |      |         |            |             |      |       |            |       |  |
|--|--|--|-------------------------------------|---------------------|------------------------|------------------------|-------|-------|----------|-------|-------|----------|--------|-------|---------|-------|-------|---------|-------|-------|---|----------|------|-------|------------|------------|------|---------|------------|-------------|------|-------|------------|-------|--|
| SEE SHEET ONE<br>EC NO: IPG2015-0070<br>DRWN: J WALLACE 2013/12/17<br>CHKD: SMC GREEVY 2014/07/18<br>APPR: F DUGGAN 2014/07/21 | QUALITY SYMBOLS                                      | GENERAL TOLERANCES (UNLESS SPECIFIED)  | DIMENSION STYLE<br>MM ONLY          | SCALE<br>1:1        | DESIGN UNITS<br>METRIC | THIRD ANGLE PROJECTION |       |       |          |       |       |          |        |       |         |       |       |         |       |       |   |          |      |       |            |            |      |         |            |             |      |       |            |       |  |
|  | ▽=0<br>∇=0   | <table border="1"> <tr> <td></td> <td>mm</td> <td>INCH</td> </tr> <tr> <td>4 PLACES</td> <td>± ---</td> <td>± ---</td> </tr> <tr> <td>3 PLACES</td> <td>± ---</td> <td>± ---</td> </tr> <tr> <td>2 PLACES</td> <td>± 0.20</td> <td>± ---</td> </tr> <tr> <td>1 PLACE</td> <td>± 0.5</td> <td>± ---</td> </tr> <tr> <td>0 PLACE</td> <td>± ---</td> <td>± ---</td> </tr> </table> |                                     | mm                  | INCH                   | 4 PLACES               | ± --- | ± --- | 3 PLACES | ± --- | ± --- | 2 PLACES | ± 0.20 | ± --- | 1 PLACE | ± 0.5 | ± --- | 0 PLACE | ± --- | ± --- | <table border="1"> <tr> <td>DRAWN BY</td> <td>DATE</td> </tr> <tr> <td>TVOGT</td> <td>2009/03/26</td> </tr> <tr> <td>CHECKED BY</td> <td>DATE</td> </tr> <tr> <td>RSILLER</td> <td>2009/03/30</td> </tr> <tr> <td>APPROVED BY</td> <td>DATE</td> </tr> <tr> <td>AVOGT</td> <td>2009/03/31</td> </tr> </table> | DRAWN BY | DATE | TVOGT | 2009/03/26 | CHECKED BY | DATE | RSILLER | 2009/03/30 | APPROVED BY | DATE | AVOGT | 2009/03/31 | TITLE |  |
|  |  | mm   | INCH                                |                     |                        |                        |       |       |          |       |       |          |        |       |         |       |       |         |       |       |   |          |      |       |            |            |      |         |            |             |      |       |            |       |  |
| 4 PLACES   | ± ---  | ± ---  |                                     |                     |                        |                        |       |       |          |       |       |          |        |       |         |       |       |         |       |       |   |          |      |       |            |            |      |         |            |             |      |       |            |       |  |
| 3 PLACES   | ± ---  | ± ---  |                                     |                     |                        |                        |       |       |          |       |       |          |        |       |         |       |       |         |       |       |   |          |      |       |            |            |      |         |            |             |      |       |            |       |  |
| 2 PLACES   | ± 0.20   | ± ---  |                                     |                     |                        |                        |       |       |          |       |       |          |        |       |         |       |       |         |       |       |   |          |      |       |            |            |      |         |            |             |      |       |            |       |  |
| 1 PLACE  | ± 0.5  | ± ---  |                                     |                     |                        |                        |       |       |          |       |       |          |        |       |         |       |       |         |       |       |   |          |      |       |            |            |      |         |            |             |      |       |            |       |  |
| 0 PLACE  | ± ---  | ± ---  |                                     |                     |                        |                        |       |       |          |       |       |          |        |       |         |       |       |         |       |       |   |          |      |       |            |            |      |         |            |             |      |       |            |       |  |
| DRAWN BY   | DATE   |  |                                     |                     |                        |                        |       |       |          |       |       |          |        |       |         |       |       |         |       |       |   |          |      |       |            |            |      |         |            |             |      |       |            |       |  |
| TVOGT  | 2009/03/26   |  |                                     |                     |                        |                        |       |       |          |       |       |          |        |       |         |       |       |         |       |       |   |          |      |       |            |            |      |         |            |             |      |       |            |       |  |
| CHECKED BY   | DATE   |  |                                     |                     |                        |                        |       |       |          |       |       |          |        |       |         |       |       |         |       |       |   |          |      |       |            |            |      |         |            |             |      |       |            |       |  |
| RSILLER  | 2009/03/30   |  |                                     |                     |                        |                        |       |       |          |       |       |          |        |       |         |       |       |         |       |       |   |          |      |       |            |            |      |         |            |             |      |       |            |       |  |
| APPROVED BY  | DATE   |  |                                     |                     |                        |                        |       |       |          |       |       |          |        |       |         |       |       |         |       |       |   |          |      |       |            |            |      |         |            |             |      |       |            |       |  |
| AVOGT  | 2009/03/31   |  |                                     |                     |                        |                        |       |       |          |       |       |          |        |       |         |       |       |         |       |       |   |          |      |       |            |            |      |         |            |             |      |       |            |       |  |
| ANGULAR ± .5 °   | DRAFT WHERE APPLICABLE MUST REMAIN WITHIN DIMENSIONS | MATERIAL NO.<br><b>850832414</b>   | DOCUMENT NO.<br><b>SD-85083-300</b> | SHEET NO.<br>5 OF 8 |                        |                        |       |       |          |       |       |          |        |       |         |       |       |         |       |       |   |          |      |       |            |            |      |         |            |             |      |       |            |       |  |
| THIS DRAWING CONTAINS INFORMATION THAT IS PROPRIETARY TO MOLEX INCORPORATED AND SHOULD NOT BE USED WITHOUT WRITTEN PERMISSION  |  |  |                                     |                     |                        |                        |       |       |          |       |       |          |        |       |         |       |       |         |       |       |   |          |      |       |            |            |      |         |            |             |      |       |            |       |  |

10 9 8 7 6 5 4 3 2 1

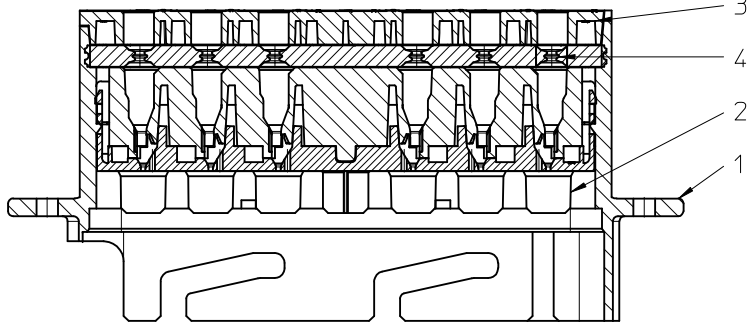

R-R

|                  |                  |      |          |
|------------------|------------------|------|----------|
| 4                | MALE BACK SEAL   | 1    | RUST RED |
| 3                | MALE REAR COVER  | 1    | BLACK    |
| 2                | MALE FRONT COVER | 1    | GREEN    |
| 1                | MALE HOUSING     | 1    | BLACK    |
| No.              | DESCRIPTION      | QTY. | COLOUR   |
| BILL OF MATERIAL |                  |      |          |

TERMINAL POSITION G3  
TERMINAL POSITION A3

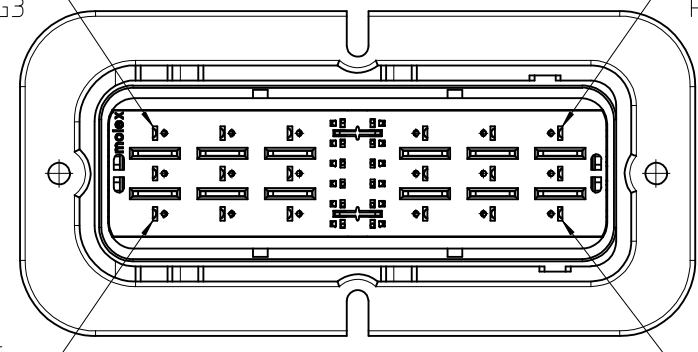

TERMINAL POSITION G1  
TERMINAL POSITION A1

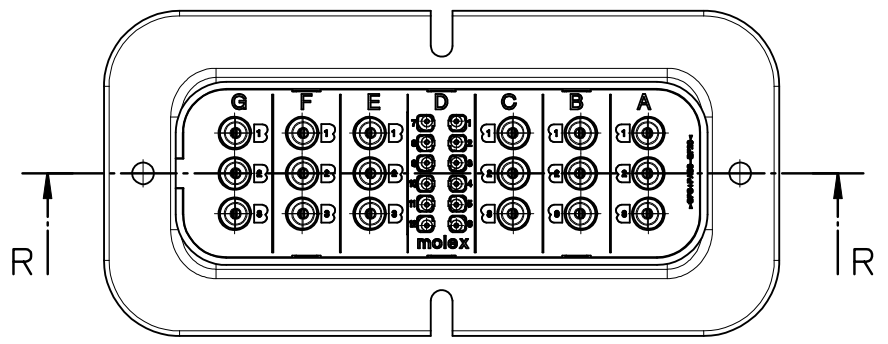

R

R

NOTES:

1. REFERENCE SHEET 1 FOR UNSPECIFIED NOTES AND DIMENSIONS
2. MX150 BLADE TERMINALS PER SD-33000-001 TO BE USED WITH THIS ASSEMBLY IN CAVITY D CRIMPED WITH CABLE INSULATION OUTER DIAMETER IN THE RANGE 1.5mm TO 2.7mm
3. MX150L BLADE TERMINALS PER SD-19431-00\* TO BE USED WITH THIS ASSEMBLY IN CAVITY A, B, C, E, F AND G CRIMPED WITH CABLE INSULATION OUTER DIAMETER IN THE RANGE 3.0mm TO 5.0mm
4. MATES WITH: SRC 12+18ABCEFG POWER RECEPTACLE HOUSING ASSEMBLY PART NUMBER 850841218 PER SD-85084-700

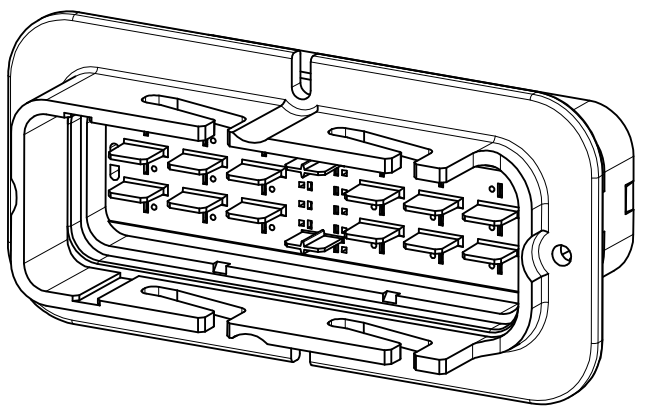

|  |             |  |   |   |   |                  |   |  |  |
|--|-------------|--|---|---|---|------------------|---|--|--|
| SEE SHEET ONE<br>EC NO: IPG2015-0070<br>DRWN: J WALLACE 2013/12/17<br>CHKD: S MCGREEVY 2014/07/18<br>APPR: F DUGGAN 2014/10/21 | DESCRIPTION | QUALITY SYMBOLS                                      | GENERAL TOLERANCES (UNLESS SPECIFIED)   | DIMENSION STYLE   | SCALE   | DESIGN UNITS     | THIRD ANGLE PROJECTION                      |  |  |
|  |             | ▽=0<br>∇=0   | mm INCH   | MM ONLY   | 1:1   | METRIC           |   |  |  |
|  |             |  | 4 PLACES ± --- ± ---<br>3 PLACES ± --- ± ---<br>2 PLACES ± 0.20 ± ---<br>1 PLACE ± 0.5 ± ---<br>0 PLACE ± --- ± --- | DRAWN BY TVOGT<br>CHECKED BY RSILLER<br>APPROVED BY AVOGT   | DATE 2009/03/26<br>DATE 2009/03/30<br>DATE 2009/03/31 | TITLE            | SRC MIXED POWER MALE BLADE HOUSING ASSEMBLY |  |  |
|  |             |  | ANGULAR ± .5 °  | MATERIAL NO. 850831218  | DOCUMENT NO. SD-85083-300                             | SHEET NO. 6 OF 8 |   |  |  |
|  |             | DRAFT WHERE APPLICABLE MUST REMAIN WITHIN DIMENSIONS | SIZE A3   | THIS DRAWING CONTAINS INFORMATION THAT IS PROPRIETARY TO MOLEX INCORPORATED AND SHOULD NOT BE USED WITHOUT WRITTEN PERMISSION |   |                  |   |  |  |

9 8 7 6 5 4 3 2 1

10 9 8 7 6 5 4 3 2 1

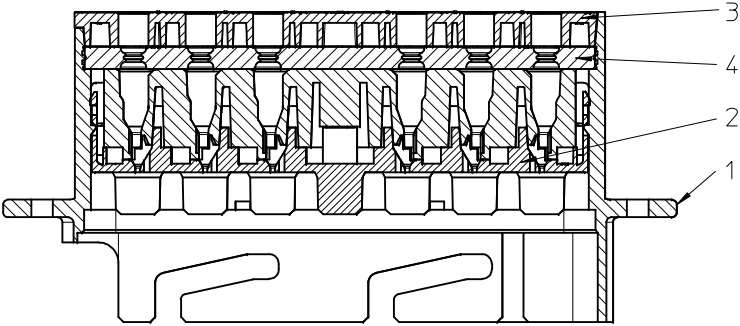

U-U

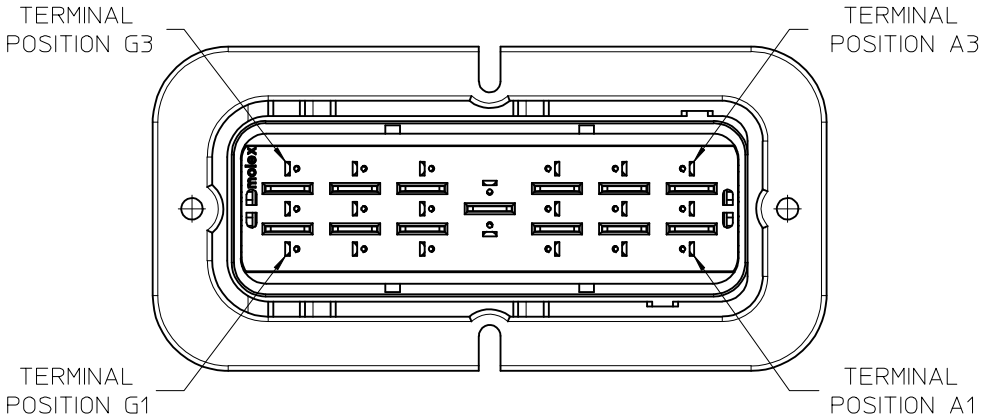

|                  |                  |      |          |
|------------------|------------------|------|----------|
| 4                | MALE BACK SEAL   | 1    | RUST RED |
| 3                | MALE REAR COVER  | 1    | BLACK    |
| 2                | MALE FRONT COVER | 1    | GREEN    |
| 1                | MALE HOUSING     | 1    | BLACK    |
| No.              | DESCRIPTION      | QTY. | COLOUR   |
| BILL OF MATERIAL |                  |      |          |

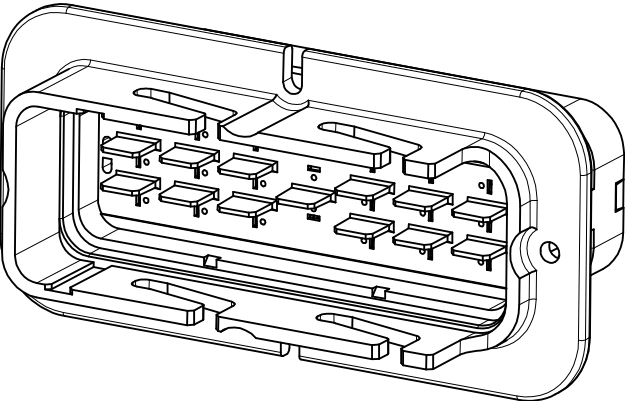
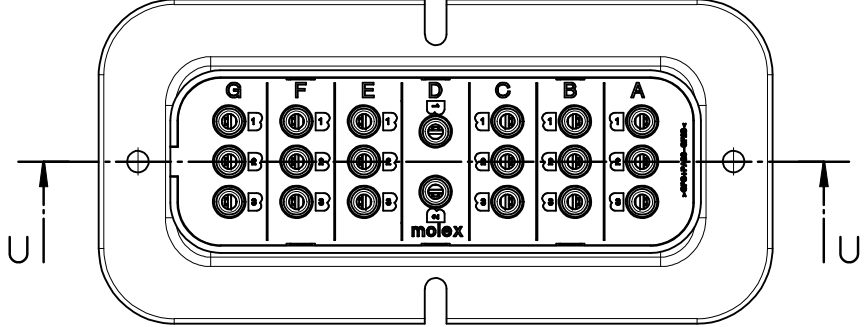

- NOTES:
1. REFERENCE SHEET 1 FOR UNSPECIFIED NOTES AND DIMENSIONS
  2. MX150L BLADE TERMINALS PER SD-19431-00\* TO BE USED WITH THIS ASSEMBLY IN ALL CAVITIES CRIMPED WITH CABLE INSULATION OUTER DIAMETER IN THE RANGE 3.0mm TO 5.0mm
  3. MATES WITH: SRC 0+20ABCDEFGH POWER RECEPTACLE HOUSING ASSEMBLY PART NUMBER 850840020 PER SD-85084-700

|  |  |                                       |                           |                              |   |  |                        |                        |
|--|--|---------------------------------------|---------------------------|------------------------------|---|--|------------------------|------------------------|
| SEE SHEET ONE<br>EC NO: IPG2015-0070<br>DRWN: J WALLACE 2013/12/17<br>CHKD: S M GREEVY 2014/07/18<br>APPR: F DUGGAN 2014/07/21 | QUALITY SYMBOLS                                      | GENERAL TOLERANCES (UNLESS SPECIFIED) |                           | DIMENSION STYLE<br>MM ONLY   |   | SCALE<br>1:1   | DESIGN UNITS<br>METRIC | THIRD ANGLE PROJECTION |
|  | ▽=0  | mm                                    | INCH                      | DRAWN BY<br>TVOGT            | DATE<br>2009/03/26  | TITLE<br>SRC MIXED POWER MALE BLADE HOUSING ASSEMBLY |                        |                        |
|  | ∇=0  | 4 PLACES ± --- ± ---                  | 3 PLACES ± --- ± ---      | CHECKED BY<br>RSILLER        | DATE<br>2009/03/30  | <b>molex</b>   |                        |                        |
|  |  | 2 PLACES ± 0.20 ± ---                 | 1 PLACE ± 0.5 ± ---       | APPROVED BY<br>AVOGT         | DATE<br>2009/03/31  |  |                        |                        |
|  | ANGULAR ± .5 °                                       |                                       | MATERIAL NO.<br>850830020 | DOCUMENT NO.<br>SD-85083-300 |   | SHEET NO.<br>7 OF 8                                  |                        |                        |
|  | DRAFT WHERE APPLICABLE MUST REMAIN WITHIN DIMENSIONS |                                       |                           | SIZE<br>A3                   | THIS DRAWING CONTAINS INFORMATION THAT IS PROPRIETARY TO MOLEX INCORPORATED AND SHOULD NOT BE USED WITHOUT WRITTEN PERMISSION |  |                        |                        |

9 8 7 6 5 4 3 2 1

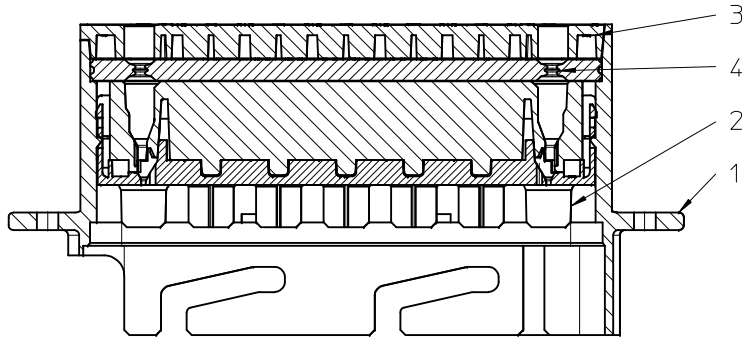

Q-Q

|                  |                  |      |          |
|------------------|------------------|------|----------|
| 4                | MALE BACK SEAL   | 1    | RUST RED |
| 3                | MALE REAR COVER  | 1    | BLACK    |
| 2                | MALE FRONT COVER | 1    | GREEN    |
| 1                | MALE HOUSING     | 1    | BLACK    |
| No.              | DESCRIPTION      | QTY. | COLOUR   |
| BILL OF MATERIAL |                  |      |          |

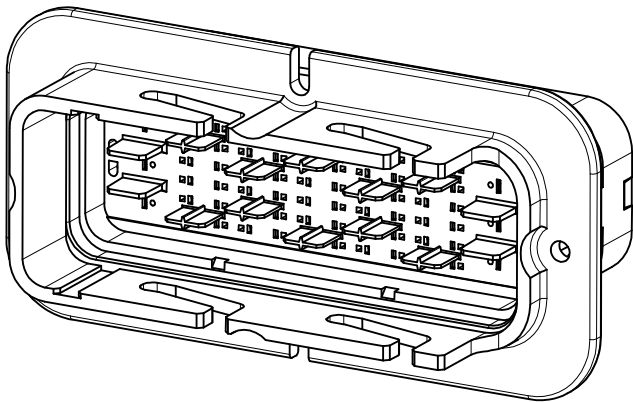
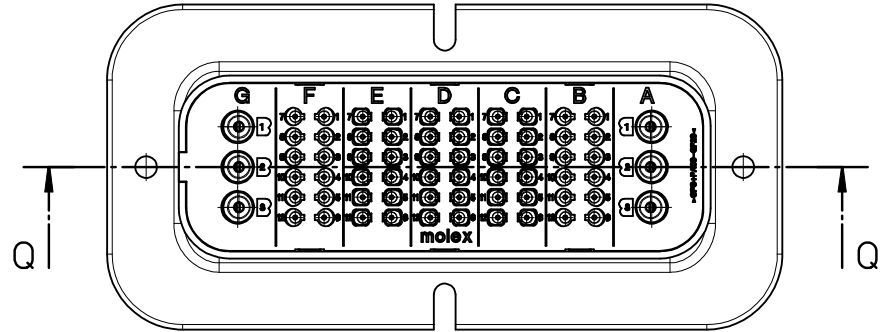
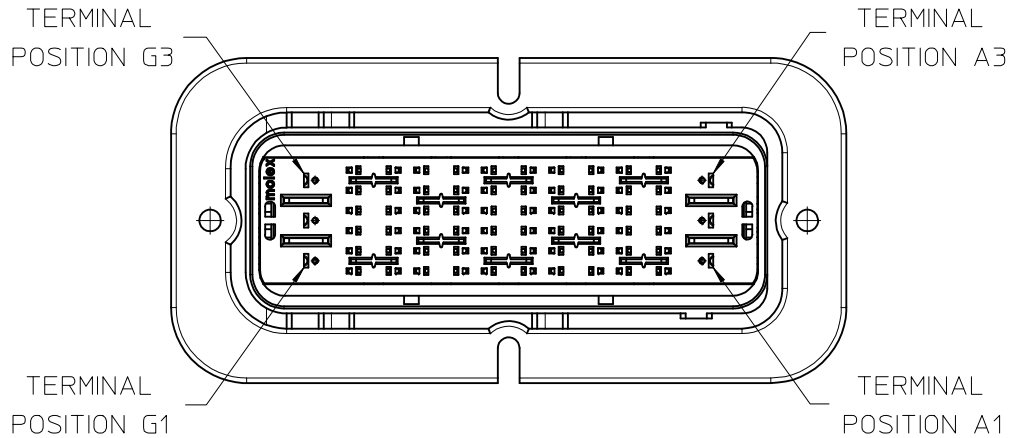

NOTES:

1. REFERENCE SHEET 1 FOR UNSPECIFIED NOTES AND DIMENSIONS
2. MX150 BLADE TERMINALS PER SD-33000-001 TO BE USED WITH THIS ASSEMBLY IN CAVITIES B, C, D, E AND F CRIMPED WITH CABLE INSULATION OUTER DIAMETER IN THE RANGE 1.5mm TO 2.7mm
3. SRC BLADE TERMINALS PER SD-93642-001 MAY BE USED WITH THIS ASSEMBLY IN CAVITIES B AND F CRIMPED WITH 2.5mm<sup>2</sup> (13AWG) CABLE INSULATION OUTER DIAMETER IN THE RANGE 2.7mm TO 3.0mm
4. MX150L BLADE TERMINALS PER SD-19431-00\* TO BE USED WITH THIS ASSEMBLY IN CAVITIES A AND G CRIMPED WITH CABLE INSULATION OUTER DIAMETER IN THE RANGE 3.0mm TO 5.0mm
5. MATES WITH: SRC 60+6AG POWER 2.5 RECEPTACLE HOUSING ASSEMBLY PART NUMBER 850846025 PER SD-85084-700

|  |             |  |                                       |   |                            |                      |  |                           |                        |  |
|--|-------------|--|---------------------------------------|---|----------------------------|----------------------|--|---------------------------|------------------------|--|
| SEE SHEET ONE<br>EC NO: IPG2015-0070<br>DRWN: J WALLACE 2013/12/17<br>CHKD: SMC GREEVY 2014/07/18<br>APPR: F DUGGAN 2014/07/21 | DESCRIPTION | QUALITY SYMBOLS                                      | GENERAL TOLERANCES (UNLESS SPECIFIED) |   | DIMENSION STYLE<br>MM ONLY |                      | SCALE<br>1:1   | DESIGN UNITS<br>METRIC    | THIRD ANGLE PROJECTION |  |
|  |             | ▽=0  | mm                                    | INCH  | DRAWN BY<br>TVOGT          | DATE<br>2009/03/26   | TITLE<br>SRC MIXED POWER MALE BLADE HOUSING ASSEMBLY |                           |                        |  |
|  |             | ∇=0  | 4 PLACES ± --- ± ---                  | 3 PLACES ± --- ± ---  | CHECKED BY<br>RSILLER      | DATE<br>2009/03/30   |  |                           |                        |  |
|  |             |  |                                       | 2 PLACES ± 0.20 ± ---   | 1 PLACE ± 0.5 ± ---        | APPROVED BY<br>AVOGT | DATE<br>2009/03/31                                   | MATERIAL NO.<br>850836025 |                        |  |
|  |             | 0 PLACE ± --- ± ---                                  | ANGULAR ± .5 °                        | DOCUMENT NO.<br>SD-85083-300  |                            | SHEET NO.<br>8 OF 8  |  |                           |                        |  |
|  |             | DRAFT WHERE APPLICABLE MUST REMAIN WITHIN DIMENSIONS |                                       | THIS DRAWING CONTAINS INFORMATION THAT IS PROPRIETARY TO MOLEX INCORPORATED AND SHOULD NOT BE USED WITHOUT WRITTEN PERMISSION |                            |                      |  |                           |                        |  |