

THIS DRAWING IS UNPUBLISHED. RELEASED FOR PUBLICATION
 © COPYRIGHT BY ALL RIGHTS RESERVED.

LOC		DIST		REVISIONS			
P	LTR	DESCRIPTION	DATE	DWN	APVD		
AP	-	D1	19MAR11	RK	HMR	REVISED PER ECO-11-005139	

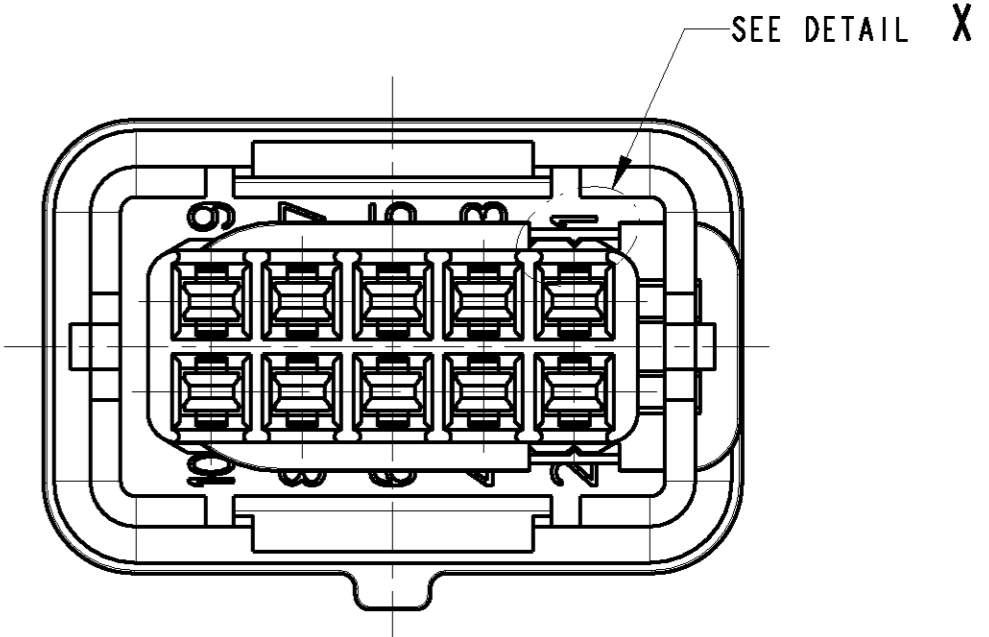

SECTION A-A

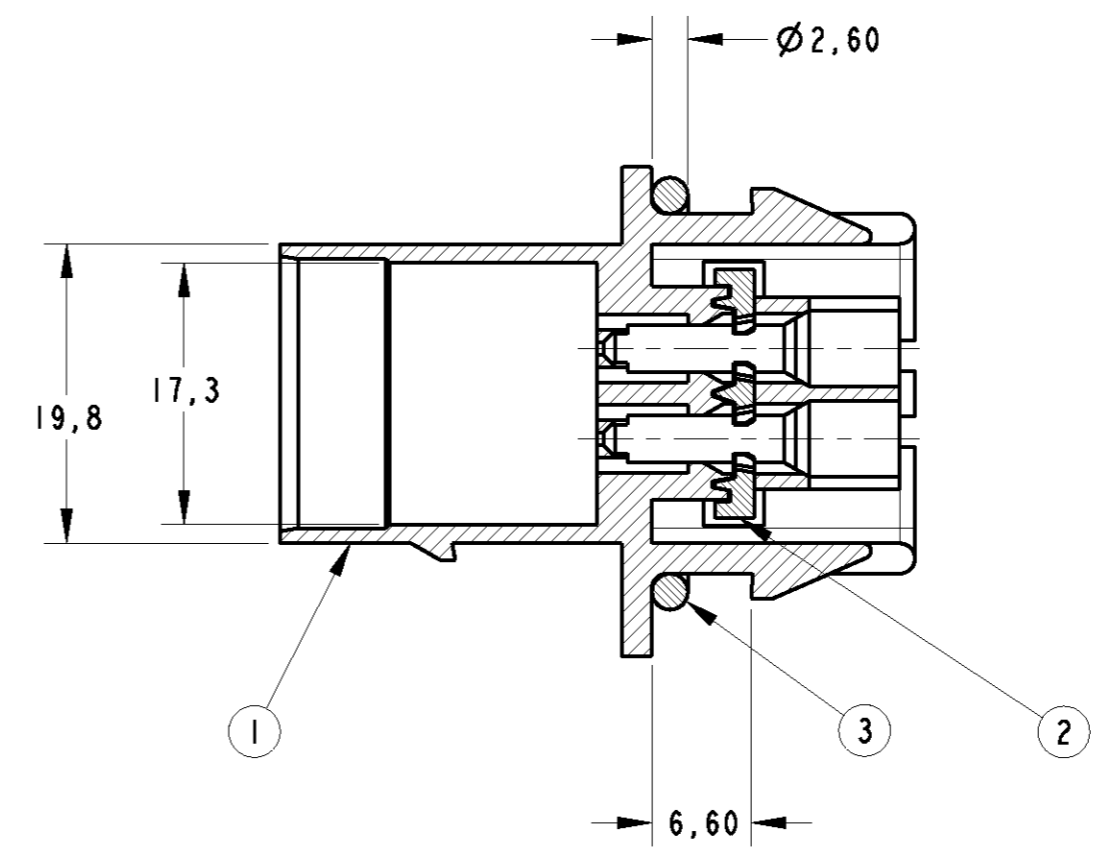
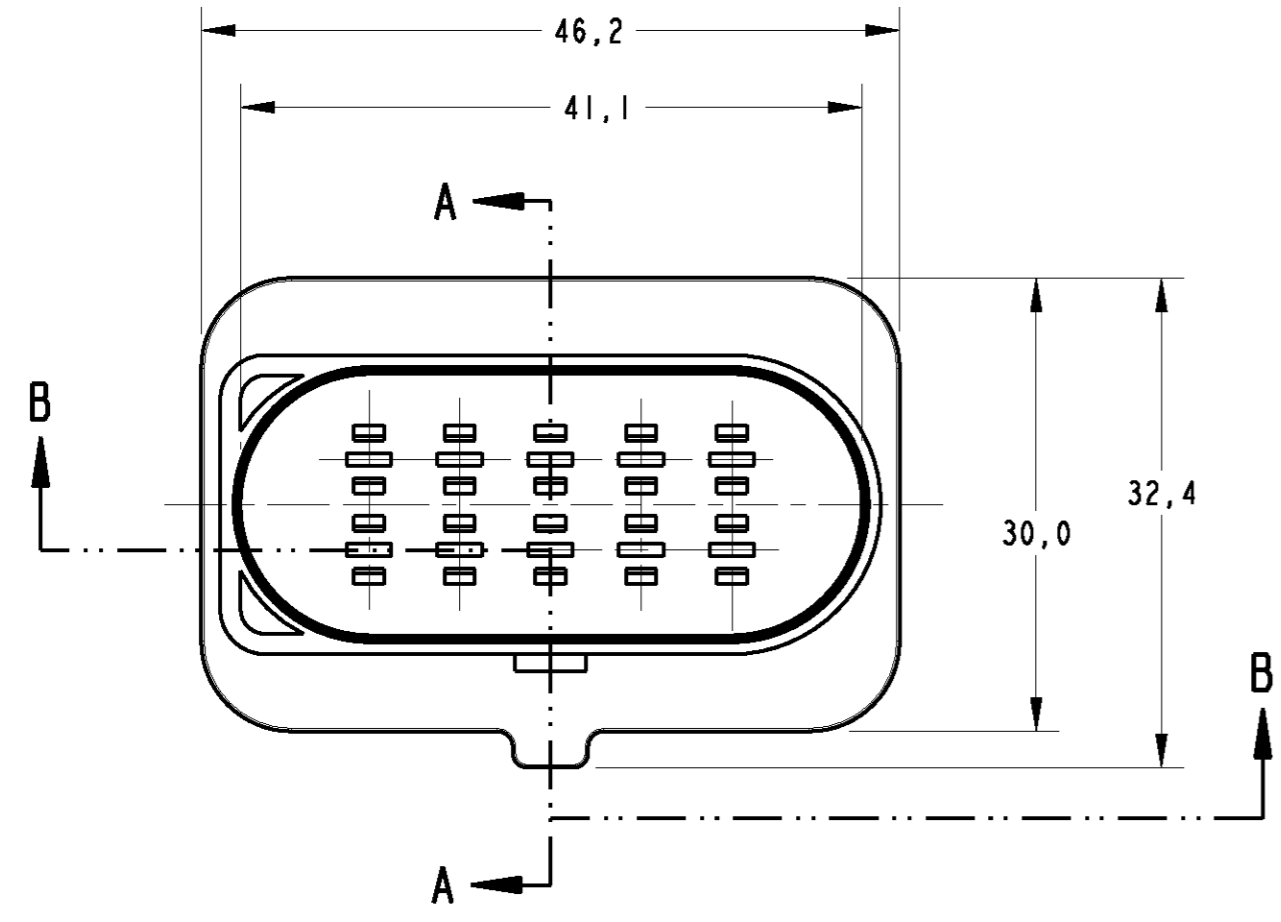
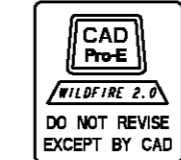
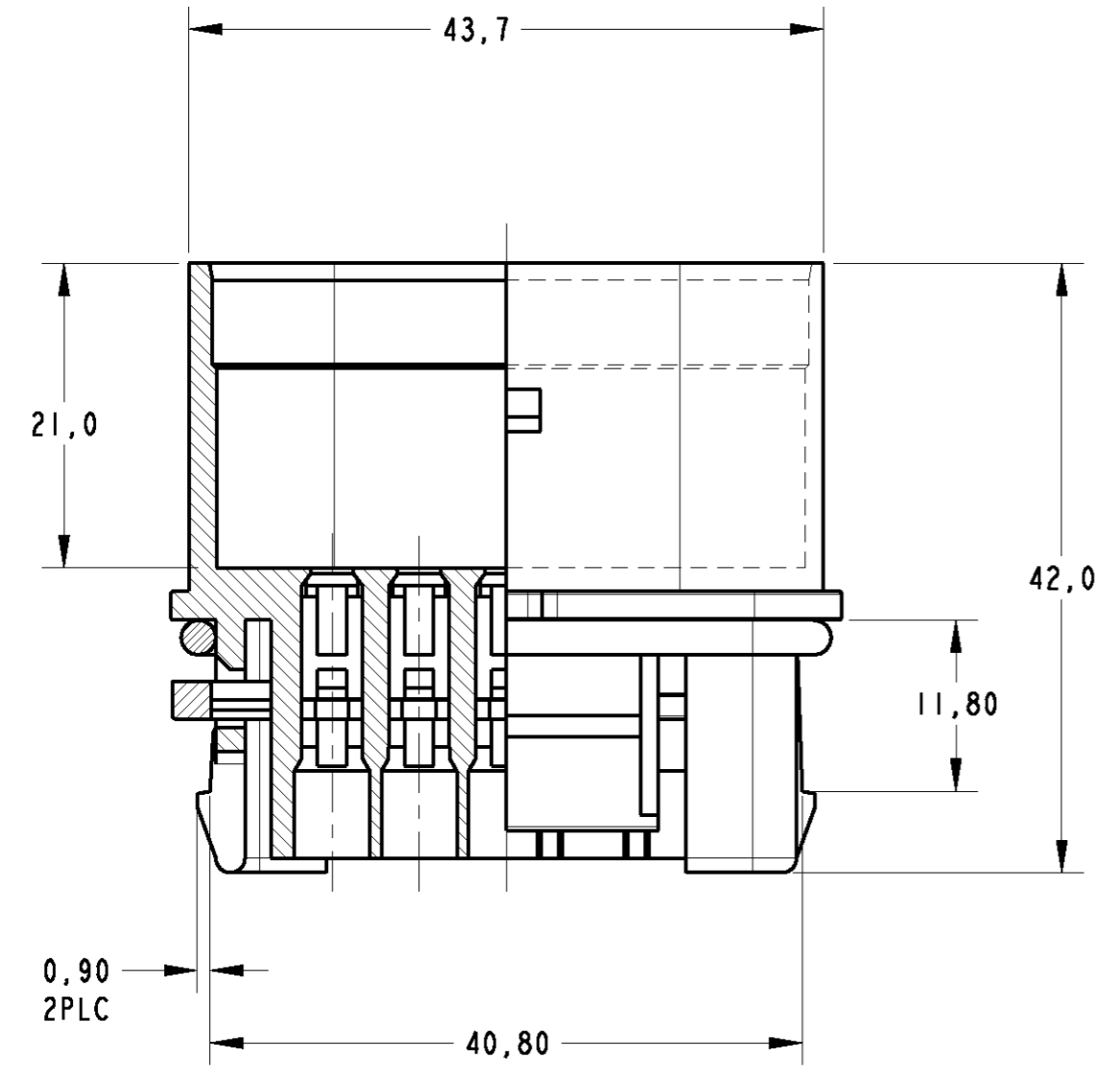

SECTION B-B

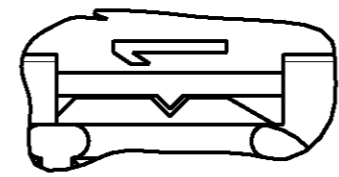

DETAIL X
 SCALE 5:1
 AS PEÇAS SÃO FORNECIDAS COMO MOSTRADAS.
 THE PARTS MUST BE SUPPLIED AS SHOWN.

- 1 - USAR TERMINAIS CONFORME DESENHO DE CLIENTE 1355364.
- 1 - USED WITH TERMINALS ACC. TO CUSTOMER DRAWING 1355364.
- 2 - USADO COM 493577.
- 3 - USED ON 493577.

GRAVAÇÃO MARKING	
LOGOTIPO TE	TE LOGO
CÓDIGO PAÍS PRODUTOR	MANUFACTURER COUNTRY CODE
NOMENCLATURA MATERIAL	MATERIAL NOMENCLATURE
NÚMERO COMPONENTE TE	CONNECTIVITY COMPONENT NUMBER
NÚMERO CAVIDADE	CAVITY NUMBER
IDENTIFICAÇÃO CIRCUITO	CIRCUIT IDENTIFICATION
NÚMERO PEÇA CLIENTE	CUSTOMER PART NUMBER
REV. + LETRA	REV. DES. REV. + DWG REV. LETTER

REQ. PER ASSY	DESCRIPTION	MATERIAL	FINISH
1 - 4	ORING	SILICONE	NATURAL
- 1	3 ORING	NBR	PRETO / BLACK
1 1	2 SPACER, 10 POSN. J.P.TIMER TAB.	PBT+10% FV/GF	VIOLETA / VIOLET
1 1	1 HSG., 10 POSN. J.P.TIMER, TAB.	PA 6.6+25% FV/GF	PRETO / BLACK

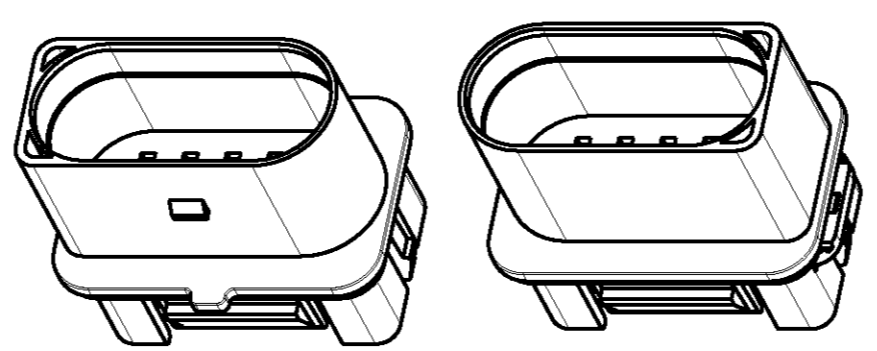

PERSPECTIVE VIEWS
 SCALE 1:1

DIMENSIONS: mm		TOLERANCES UNLESS OTHERWISE SPECIFIED:		DWN M.R.BRIZ 10AUG98		CHK P.L.FARIA 25SEP98		APVD P.R.SILVA 25MAY98		NAME HSG. ASS'Y 10 POSN. J. P. TIMER TAB.	
0 PLC ±		1 PLC ±0.3		PRODUCT SPEC -		APPLICATION SPEC -		WEIGHT -		SIZE A2	
2 PLC ±		3 PLC ±		MATERIAL SEE TABLE		SEE TABLE		CUSTOMER DRAWING		SCALE 2:1	
4 PLC ±		ANGLES ±1°		FINISH		CAGE CODE 00779		DRAWING NO. C-493571		RESTRICTED TO -	
SHEET 1		OF 1		REV D1		SHEET 1		OF 1		REV D1	

493571