

# **Instruction manual for Evaluation Board of TB67H400AFNG**

May 13, 2016

Re v.1.0

## 【Outline】

The TB67H400AFNG is a dual channel H-bridge driver corresponding to the constant current PWM control system and the direct PWM control system. It can control two brushed DC motors independently.

BiCD process is adopted. Rating of 50V and 4.0A per channel is realized.

In operating in Large mode, 1ch high current (max. 8.0A) drive is also possible.

This evaluation board mounts necessary components to evaluate the IC.

Brushed DC motor can be controlled by the constant current PWM drive and the direct PWM drive.

Please sense controllability of brushed DC motor applying the TB67H400AFTG.

## 【Note】

In using, please be careful about thermal condition sufficiently.

As for each control signal, please refer to the IC specification by accessing to the below URL.

<http://toshiba.semicon-storage.com/info/lookup.jsp?pid=TB67H400AFNG&lang=en&region=apc&sug=1>

Further, the application of this evaluation board is limited to the purpose of evaluating and learning the motor control. Please do not ship them to a market.

# Connection to Evaluation board

Corresponding table

(Silk name vs. Signal name)

(Note) Silk name and signal name on the board are different because the series products have the common board.

Silk name	Signal name
GND7	NC
GND6	NC
L_OUT	NC
VREFB	VREF
45	NC
VREFA	HBMODE
OSCM	OSCM
3	INA1
4	INA2
5	PWMA
7	PWMB
8	INB1
9	INB2
10	TBLKAB

Power source of VM (10V to 47V)

Brushed DC motor

Brushed DC motor

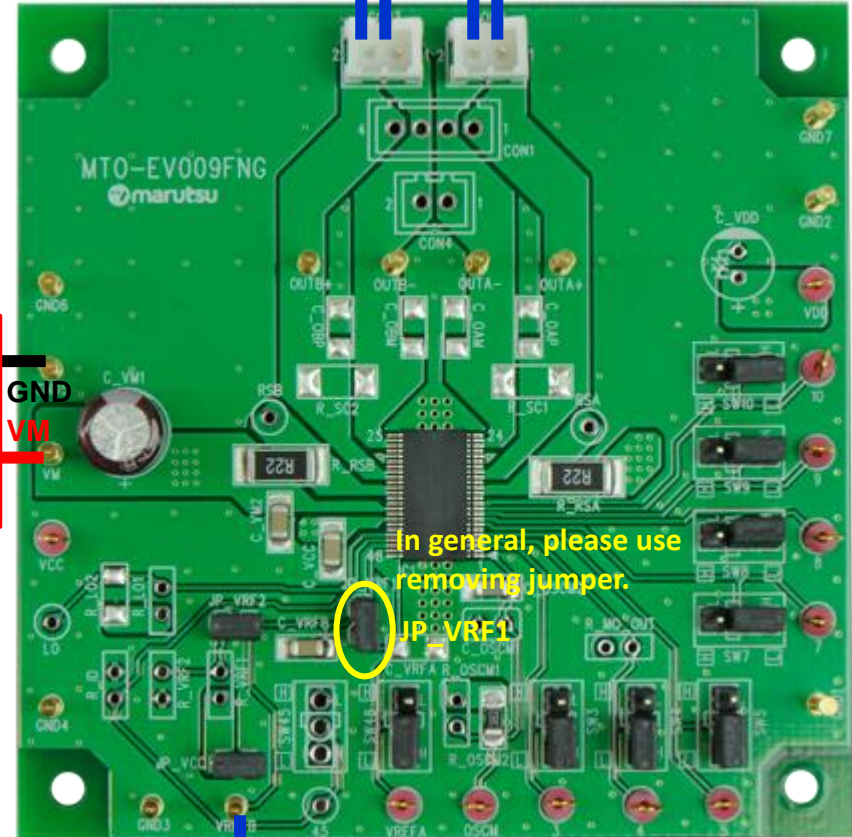

In general, please use removing jumper.

Vref(for A/B-axis)

Reference voltage for motor current set Vref (0V to 3.6V)



# Setting evaluation board2

## Setting chopping frequency of the constant current of the motor

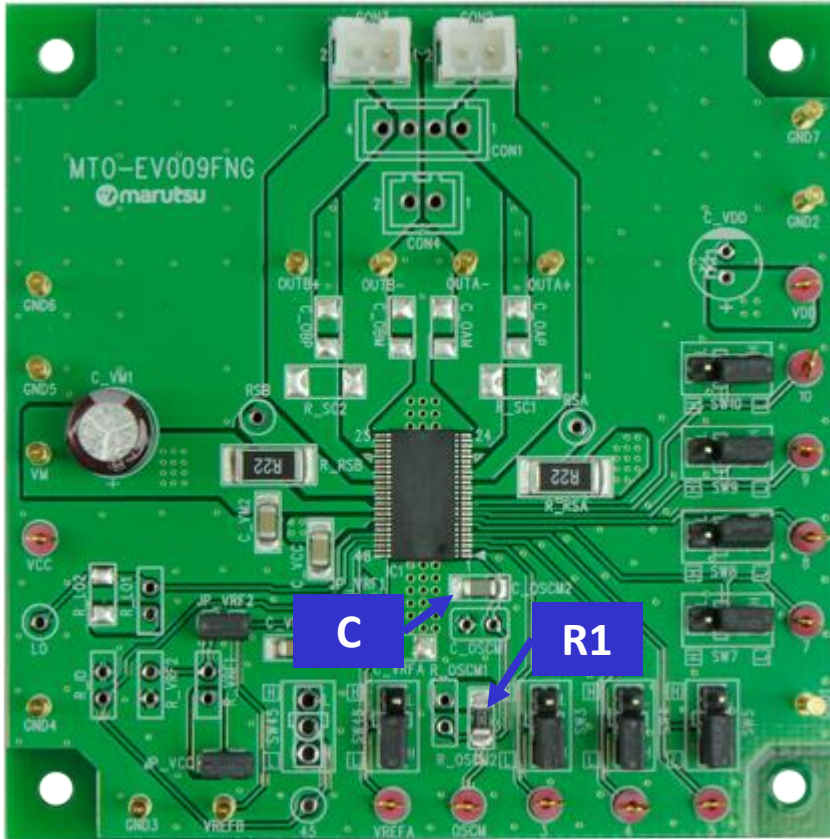

### Formula of setting chopping frequency

$$f_{OSCM} = 1 / [0.56 \times \{C \times (R1 + 500)\}]$$

$$f_{chop} = f_{OSCM} / 16$$

Recommended frequency range:

$f_{chop}$ =40kHz to 150kHz

100kHz configuration

Mounted parts are as follows;

Capacitor (C=270pF), Resistance (R1=3.6kΩ)

### Waveform of motor current

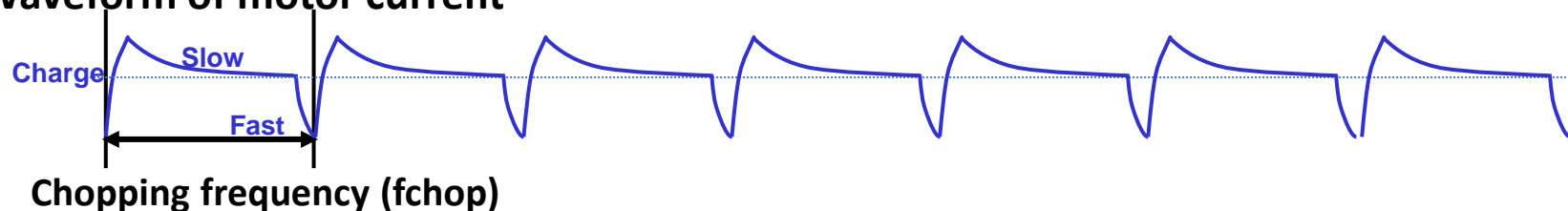

# Setting evaluation board3

## Setting motor operation

【Enhanced figure of jumper part】

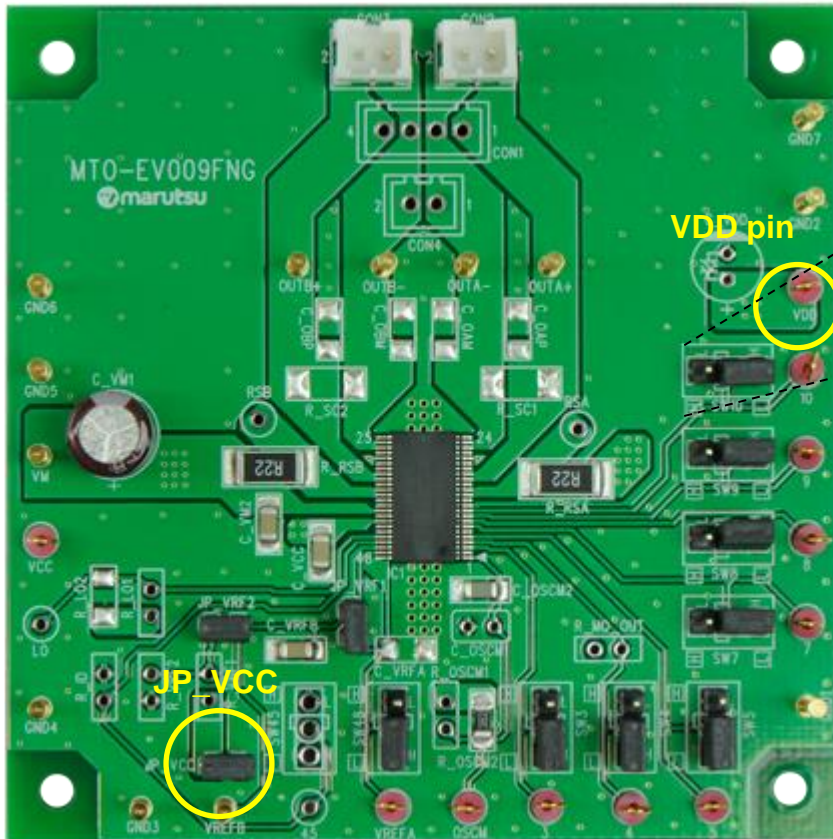

Jumper indicated above is adopted on this evaluation board to set operation of the TB67H400AFNG.

To select the function by the jumper, short-circuit JP\_VCC or supply the voltage of high level by VDD pin.

In above, fixed level of the silk near the jumper is indicated inside the white frame. Please change the short position according to the configuration of the usage function.

In case of inputting the signal externally, please remove the short pin.

# The processing method for Large mode

## Setting motor operation

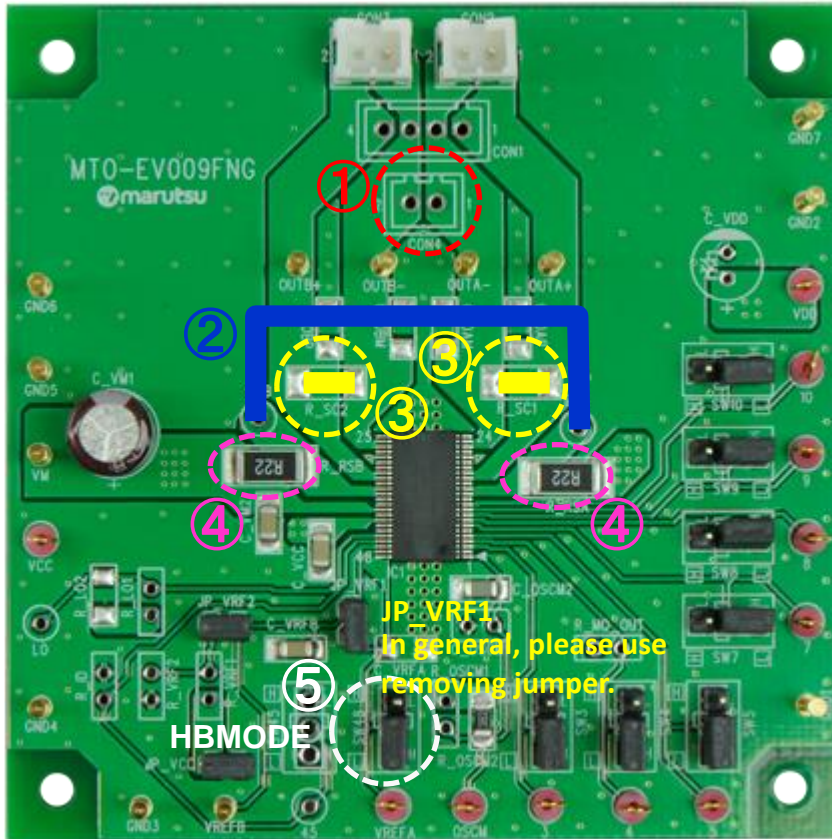

- ①: Implementation of the motor connector  
Please implement the motor connector.
- ②: Short of RSA terminal and RSB terminal  
Please connect RSA terminal and RSB terminal by wire, using hole for check pins.
- ③: 0Ω (short) resistor implementation  
When large mode uses, it should connect OUTA+(OUTB+) line and OUTA-(OUTB-) line. So, please implement 0Ω(short) resistor on these area.
- ④: RRSA and RRSB's resistor value adjustment  
In according to your motor drive current, please adjust resistance value.
- ⑤: HBMODE pin  
Please insert short pin to "H" level side. The TB67H400AFNG is set to Large mode.

# Circuit of evaluation board

