

THIS DRAWING IS UNPUBLISHED. RELEASED FOR PUBLICATION . 19
 © COPYRIGHT 19 BY AMP INCORPORATED, HARRISBURG, PA. ALL INTERNATIONAL RIGHTS RESERVED. AMP PRODUCTS MAY BE COVERED BY U.S. AND FOREIGN PATENTS AND/OR PATENTS PENDING.

| | | | | 1 | LOC G | DIST 19 |
|-----------|---|------|-----|--------------------------------|---------|-----------------|
| REVISIONS | | | | | | |
| P | F | ZONE | LTR | DESCRIPTION | DATE | APPROVED |
| ✓ | | | D | REL-1 86-1169-001, -Z P85-0528 | 5/13/86 | PM/ [Signature] |
| | ✓ | | A | REV PER G-4725 | 7/12/88 | JT/ [Signature] |
| ✓ | | | B | REV/0720-0220-92 | 1/93 | Lo/m.e. |

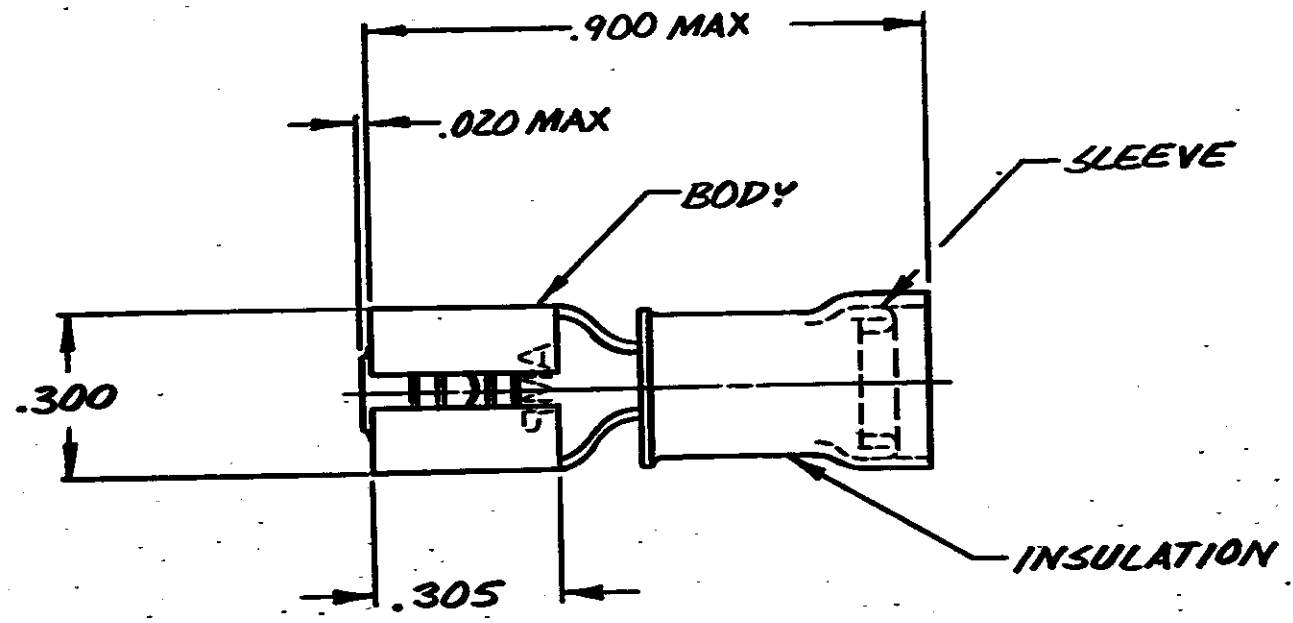

| QTY | PACKAGE TYPE | PART NO |
|-------|---------------|---------|
| — | LOOSE PIECE | 55675-1 |
| 4,000 | ON TAPE, REEL | 55675-2 |

- 1. FOR .135 MAX INSULATION DIA.
- 2. FITS .032 TAB THK.

| BODY: BRASS MIL-C-50 | 55675-2 |
|-------------------------|---------|
| SLEEVE: COPPER QQ-C-576 | |
| TIN PL MIL-T-10721 | 55675-1 |
| INSULATION: NYLON RED | |
| MATERIAL & FINISH | PART NO |

| | | | | |
|--|-------------|--------------------|--|---|
| UNLESS OTHERWISE SPECIFIED DIMENSIONS ARE IN INCHES. TOLERANCES ON: DECIMALS ± .015 ANGLES ± — | CONTRACT NO | | AMP AMP INCORPORATED Harrisburg, Pa. | |
| | DR | P. Fortney 5/14/86 | | |
| | MATERIAL | SEE TABLE | NAME | RECEPTACLE, PIDG, FASTON, 22-18, 250 |
| | FINISH | SEE TABLE | SIZE | B |
| | OTHER APPD | DSGN APPD | FSCM NO | 00779 |
| | | | DRAWING NO | 55675 |
| | | | SCALE | NTS |
| | | | SHEET | 1 OF 1 |

CUSTOMER DRAWING