

THIS DRAWING IS UNPUBLISHED. RELEASED FOR PUBLICATION .19
 © COPYRIGHT 19 BY AMP INCORPORATED. ALL RIGHTS RESERVED.

LOC	DIST	REVISIONS			
P	LTR	DESCRIPTION	DATE	DWN	APVD
AF	50	C	REV PER 0G3A-0242-00	28JUL00	JR EH

SUGGESTED MATING TAB

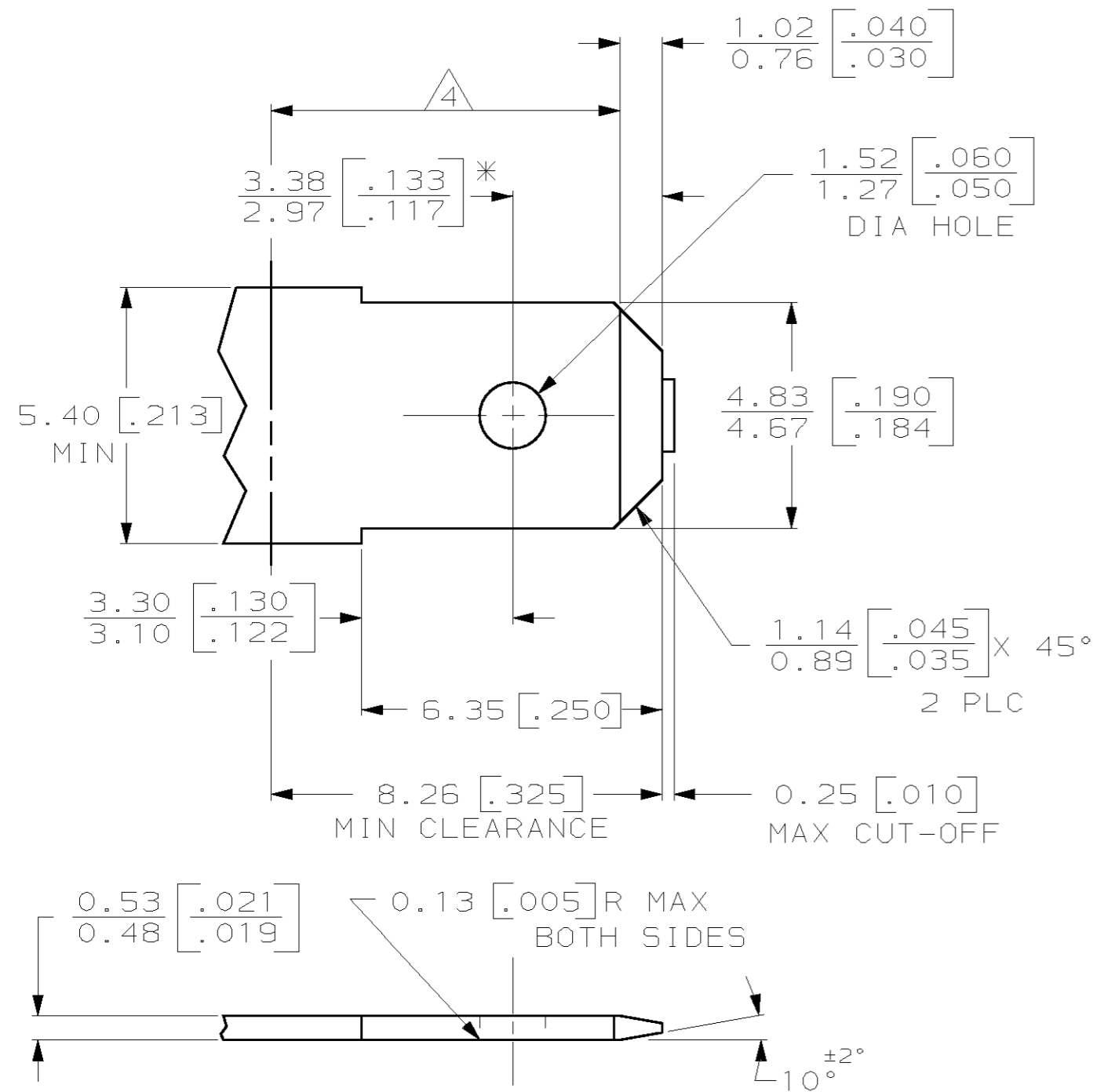

- MATL: #2 HARD BRASS OR NICKEL PLATE STEEL.
 - NO BURRS PERMISSIBLE AT HOLE.
 - TIN PLATING IS REQUIRED ON BRASS WHEN TERMINAL TEMPERATURE IS OVER 225°F.
 - MUST BE FLAT WITHIN 0.076 [0.003] OVER THIS LENGTH.
 - HOLE MUST BE SYMMETRICAL ABOUT TAB ϕ WITHIN 0.076 [0.003].
- * TO BE USED ONLY WHEN SHOULDER IS ELIMINATED.

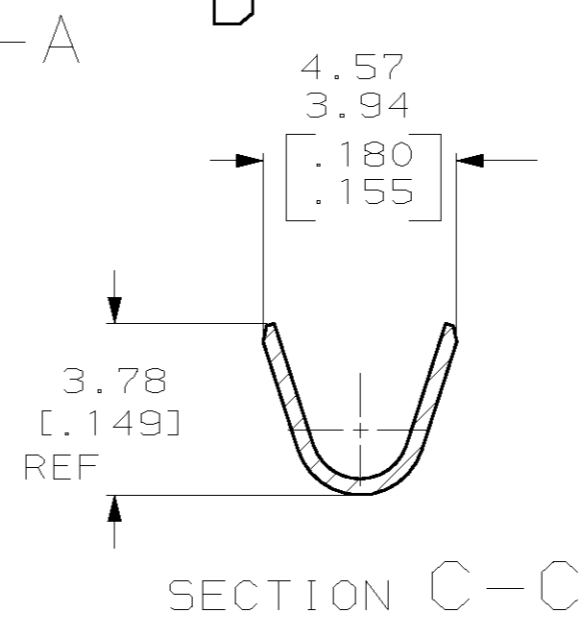
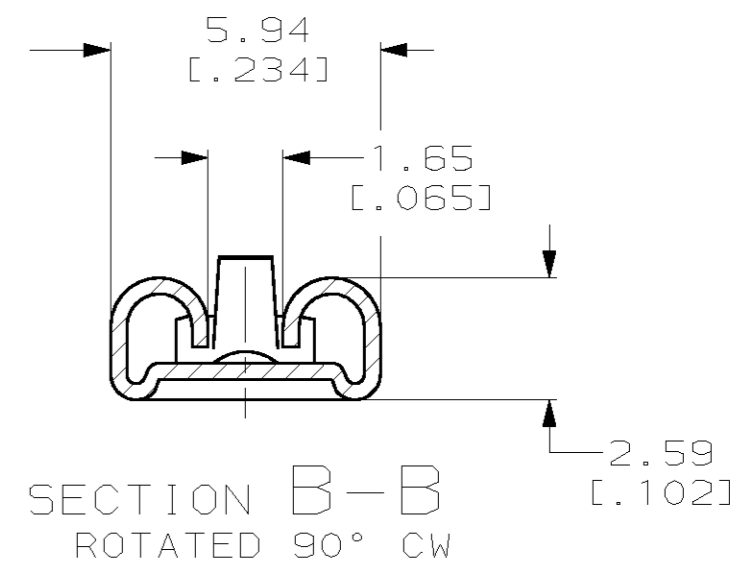
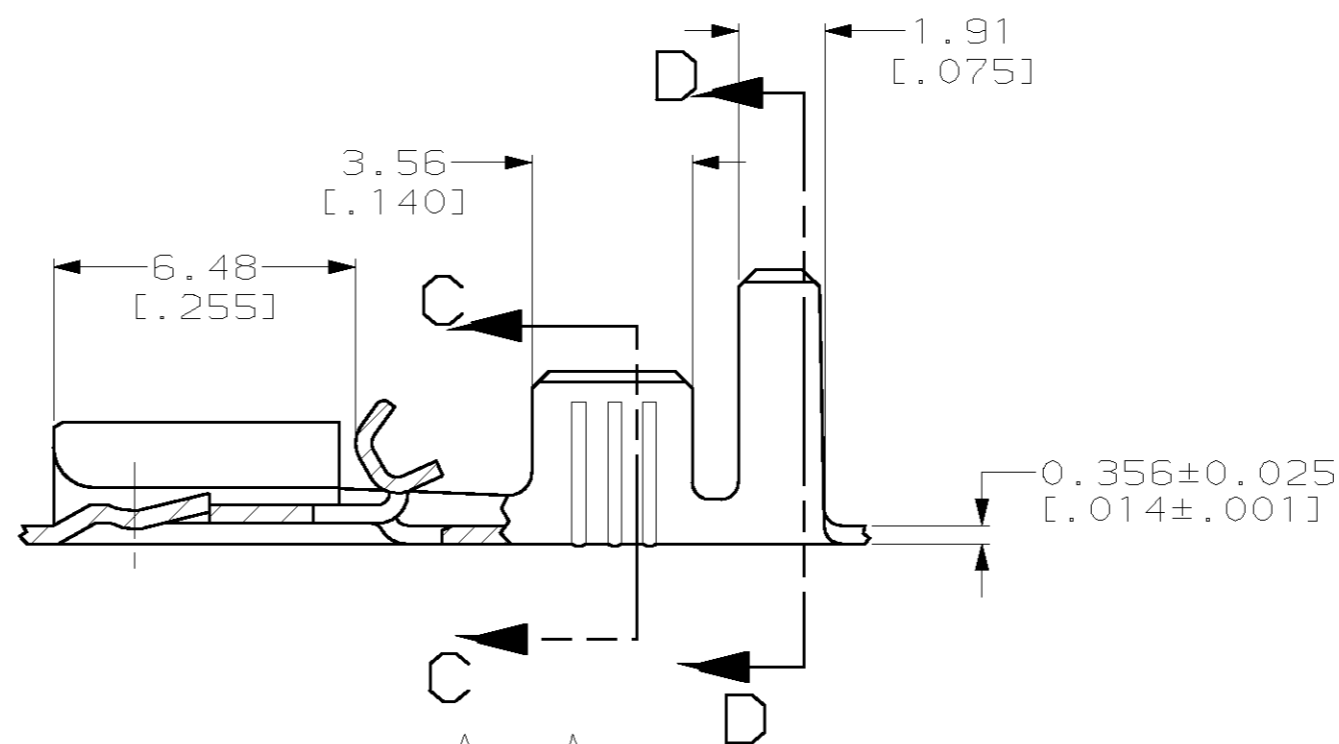
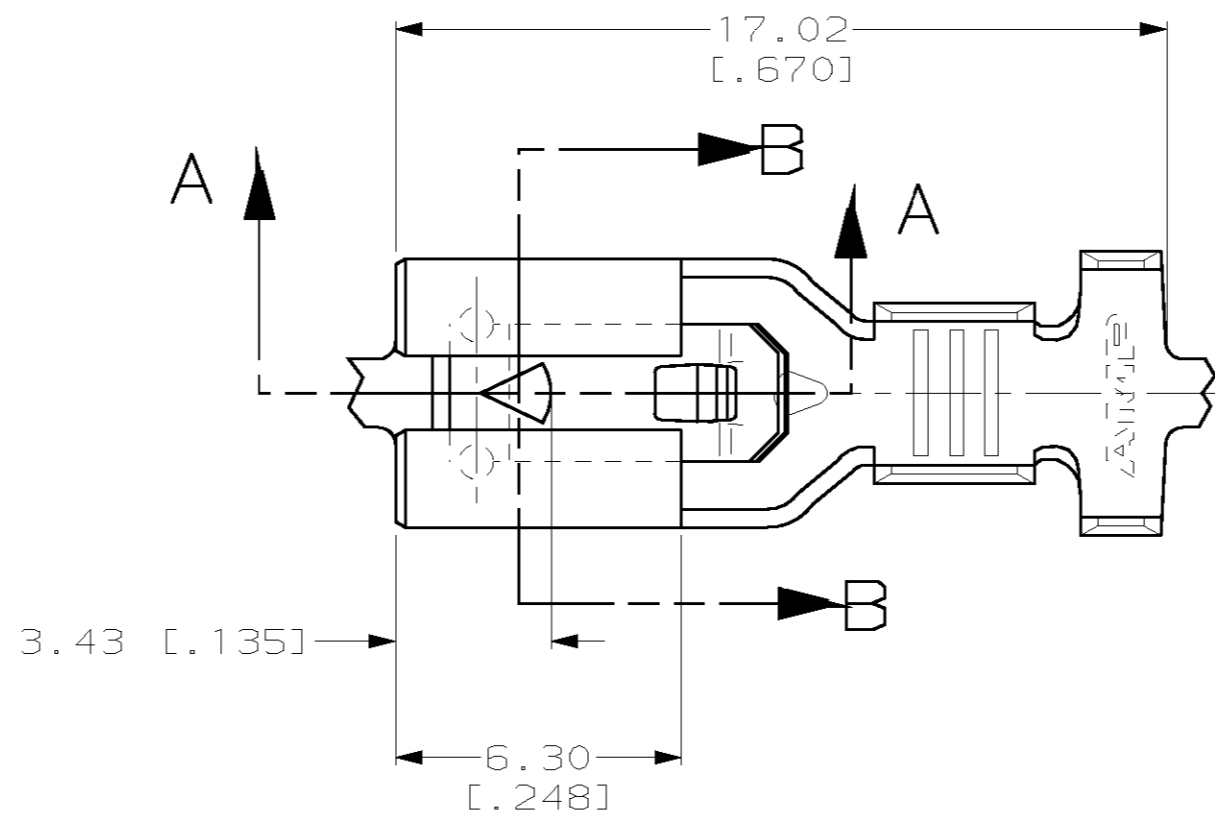

- CONTINUOUS STRIP ON REELS.
- ACCEPTS [#18-#14] SINGLE WIRE SIZES AND COMBINATION OF TWO [#18'5]. WIRE CRIMP IS 3.05 [0.120], F TYPE
- FITS INSULATION RANGE OF 3.81-5.08 [0.150-.200] DIA OR TWO WIRES AT 2.79 [0.110] MAX DIA. INSULATION CRIMP IS 5.59 [0.220], F TYPE

0.002032 [0.000800] MIN TIN	1217114-2
-	1217114-1
FINISH	PART NO.

THIS DRAWING IS A CONTROLLED DOCUMENT.		DWN	JR RUTH	9/17/98
DIMENSIONS: MM [INCHES]		CHK	MS FEHER	9/17/98
TOLERANCES UNLESS OTHERWISE SPECIFIED:		APVD	E HOWARD	9/17/98
0 PLC	±-	PRODUCT SPEC	AMP Incorporated Harrisburg, PA 17105-3608	
1 PLC	±-	APPLICATION SPEC	RECEPTACLE, POSITIVE-LOCK, MARK III, 4.75 [0.187] SERIES	
2 PLC	±0.25 [0.010]	WEIGHT	-	SIZE
3 PLC	±-	CUSTOMER DRAWING	-	CAGE CODE
4 PLC	±-	SCALE	6:1	DRAWING NO
ANGLES	±-	SHEET	1 OF 1	RESTRICTED TO
FINISH	SEE TABLE	REV	C	