

## MSC8157

### MSC8157 Six-Core Digital Signal Processor

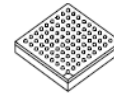

FC-PBGA-783  
29 mm x 29 mm

- Six StarCore SC3850 DSP subsystems, each with an SC3850 DSP core, 32 KB L1 instruction cache, 32 KB L1 data cache, unified 512 KB L2 cache configurable as M2 memory in 64 KB increments, memory management unit (MMU), extended programmable interrupt controller (EPIC), two general-purpose 32-bit timers, debug and profiling support, low-power Wait, Stop, and power-down processing modes, and ECC/EDC support.
- Chip-level arbitration and switching system (CLASS) that provides full fabric non-blocking arbitration between the cores and other initiators and the M2 memory, shared M3 memory, DDR SRAM controller, device configuration control and status registers, MAPLE-B, and other targets.
- 3072 KB 128-bit wide M3 memory, 2048 KBs of which can be turned off to save power.
- 96 KB boot ROM.
- Three input clocks (one global and two differential).
- Six PLLs (three global, two Serial RapidIO, one DDR PLLs).
- Second generation Multi-Accelerator Platform Engine for Baseband (MAPLE-B2) with a second generation programmable system interface (PSIF2); Turbo encoding and decoding; Viterbi decoding; FFT/iFFT and DFT/iDFT processing; downlink chip rate processing; CRC processing and insertion; equalization processing and matrix inversion; uplink batch and fast processing. Some MAPLE-B2 processors can be disabled when not required to reduce overall power consumption.
- One DDR controllers with up to a 667 MHz clock (1333 MHz data rate), 64/32 bit data bus, supporting up to a total 2 Gbyte in up to four banks (two per controller) and support for DDR3.
- DMA controller with 32 unidirectional channels supporting 16 memory-to-memory channels with up to 1024 buffer descriptors per channel, and programmable priority, buffer, and multiplexing configuration. It is optimized for DDR SDRAM.
- High-speed serial interface with a 10-lane SerDes PHY that supports two Serial RapidIO interfaces, one PCI Express interface, six CPRI lanes, and two SGMII interfaces (multiplexed). The Serial RapidIO interfaces support x1/x2/x4 operation up to 5 Gbaud with an enhanced messaging unit (eMSG) and two DMA units. The PCI Express controller supports 32- and 64-bit addressing, x1/x2/x4 link. The six CPRI controllers can support six lanes up to 6.144 Gbaud.
- QUICC Engine technology subsystem with dual RISC processors, 48 KB multi-master RAM, 48 KB instruction RAM, supporting two communication controllers for two Gigabit Ethernet interfaces (RGMII or SGMII), to offload scheduling tasks from the DSP cores, and an SPI.
- I/O Interrupt Concentrator consolidates all chip maskable interrupt and non-maskable interrupt sources and routes then to INT\_OUT/CP\_TX\_INT, NMI\_OUT/CP\_RX\_INT, and the cores.
- UART that permits full-duplex operation with a bit rate of up to 6.25 Mbps.
- Two general-purpose 32-bit timers for RTOS support per SC3850 core, four timer modules with four 16-bit fully programmable timers, two timer modules with four 32-bit fully programmable timers; and eight software watchdog timers (SWT).
- Eight programmable hardware semaphores.
- Up to 32 virtual interrupts and a virtual  $\overline{\text{NMI}}$  asserted by simple write access.
- I<sup>2</sup>C interface.
- Up to 32 GPIO ports, sixteen of which can be configured as external interrupts.
- Boot interface options include Ethernet, Serial RapidIO interface, I<sup>2</sup>C, and SPI.
- Supports **IEEE** Std. 1149.6 JTAG interface
- Low power CMOS design, with low-power standby and power-down modes, and optimized power-management circuitry.
- 45 nm SOI CMOS technology.

Freescale reserves the right to change the detail specifications as may be required to permit improvements in the design of its products.

# Table of Contents

1	Block Diagram .....	3	3.5	DC Electrical Characteristics .....	54
2	Pin Assignment .....	4	3.6	AC Timing Characteristics .....	69
	2.1 FC-PBGA Ball Layout Diagram .....	4	4	Hardware Design Considerations .....	92
	2.2 Signal Lists .....	5	5	Ordering Information .....	92
3	Electrical Characteristics .....	52	6	Package Information .....	93
	3.1 Maximum Ratings .....	52	7	Product Documentation .....	94
	3.2 Recommended Operating Conditions .....	53	8	Revision History .....	95
	3.3 Thermal Characteristics .....	54			
	3.4 CLKIN/MCLKIN Requirements .....	54			

# 1 Block Diagram

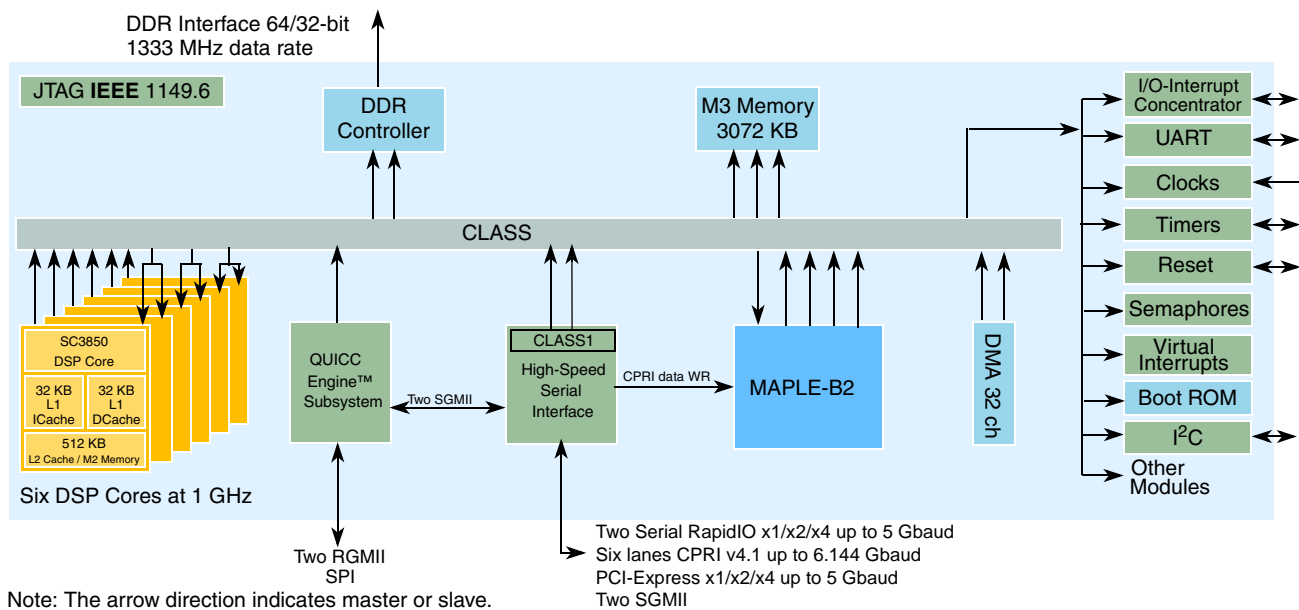

Figure 1. MSC8157 Block Diagram

# 2 Pin Assignment

This section includes a MSC8157 package ball grid array layout and table listing the signal allocation by ball location.

## 2.1 FC-PBGA Ball Layout Diagram

The top view of the FC-PBGA package is shown in [Figure 2](#) with the ball location index numbers. Only the first multiplexed signal is shown. See [Table 1](#) for a complete signal list by ball location.

	1	2	3	4	5	6	7	8	9	10	11	12	13	14	15	16	17	18	19	20	21	22	23	24	25	26	27	28			
A		VSS	MDQ57	GVDD	VSS	MDQ63	GVDD	NC	NC	NC	NC	CLKOUT	EEO	VSS	MCLKIN (optional)	VSS	CLKIN	VSS	VSS	GPI029	GPI031	GE1_TX_CTL	GE1_GTX_CLK	GE1_TX_CLK	GE1_TX_CLK	GE1_TX_CLK	GE1_TX_CLK	GE1_TX_CLK	A		
B	MDQ60	MDQ59	MDQ57	MDQ57	MDQ62	MDQ58	MDQ56	NC	VSS	NC	VSS	NC	VSS	TDO	TMS	VSS	VSS	VSS	VSS	GE2_TX_CLK	VSS	VSS	VSS	GPI025	VSS	GE_MDC	VSS	GPI018	B		
C	VSS	GVDD	MDQ61	VSS	GVDD	MDM7	VSS	NC	NC	NC	NC	NC	NC	EEO	NC	DFT_TEST	PORESET	VSS	GPI015	GE2_TX_CLK	GE2_TX_CLK	GE2_TX_CLK	GE2_TX_CLK	GE2_TX_CLK	GE2_TX_CLK	GPI030	GPI020	GE_MDI0	GPI021	C	
D	MDQ49	MDQ48	MDQ56	MDQ56	MDQ50	MDQ51	MDQ52	NC	VSS	NC	VSS	NC	VSS	NC	NMI	VSS	HRESET_IN	VSS	VSS	GPI013	NVDD	GE2_TX_CLK	VSS	GPI05	NVDD	GPI016	VSS	GPI010	D		
E	MDQ53	VSS	MDQ55	GVDD	VSS	MDQ54	GVDD	VSS	NC	NC	NC	NC	NC	NC	INT_OUT	HRESET	TCK	VSS	NVDD	GE2_RD3	VSS	VSS	NVDD	GPI027	VSS	GPI00	GPI017	GPI01	E		
F	MDQ40	MDQ41	MDQ55	MDQ55	MDQ43	MDQ47	MDM6	VDD	VSS	VDD	NC	NC	VSS	NC	NMI_OUT	VSS	TDI	VSS	GE2_RD2	GE2_RX_CTL	GE2_RX_CTL	GE2_RX_CTL	GE2_RX_CTL	GE2_RX_CTL	GPI026	GPI06	GPI022	GPI023	GPI08	F	
G	VSS	GVDD	MDM5	VSS	GVDD	MDQ46	VDD	VSS	VDD	VSS	NC	NC	NC	NC	QVDD	STOP_BS	TRST	VSS	GPI028	GE1_RD3	GE1_RD3	GE1_RX_CLK	VSS	GE1_RX_CTL	NVDD	GPI019	VSS	GPI011	G		
H	MDQ38	MDQ54	MDQ54	MDQ44	MDQ45	MDQ42	VSS	VDD	VSS	VDD	VSS	VSS	NC	QVDD	VSS	VDD	VSS	VDD	VSS	NVDD	VSS	GE1_RD0	NVDD	GE1_RD0	VSS	GPI014	NVDD	GPI012	H		
J	MDQ37	VSS	MDQ35	GVDD	MDQ33	MDQ36	VDD	VSS	VDD	VSS	VDD	VSS	VDD	VSS	VDD	VSS	VDD	VSS	VDD	VSS	NVDD	GPI024	GPI09	RCW_LSEL0	RCW_LSEL3	RCW_LSEL2	RC21	GPI03	J		
K	MCAS	MCS0	MCS1	MDQ39	MDQ32	MDQ34	VSS	VDD	VSS	VDD	VSS	VDD	VSS	VDD	VSS	VDD	VSS	VDD	VSS	VDD	VSS	GPI04	VSS	RCW_LSEL1	NVDD	GPI07	VSS	GPI02	K		
L	VSS	GVDD	NC	VSS	GVDD	MDM4	VDD	VSS	VDD	VSS	VDD	VSS	VDD	VSS	VDD	VSS	VDD	VSS	VDD	VSS	NVDD	NC	NC	VSS	VSS	VSS	SXCVSS	SXCVDD	L		
M	MCK0	MCK0	MA13	MWE	NC	NC	VSS	VDD	VSS	VDD	VSS	VDD	VSS	VDD	VSS	VDD	VSS	VDD	VSS	VDD	VSS	VDD	NC	NC	SD_A_TX	SD_A_TX	SXPVDD	SXPVSS	SD_A_RX	SD_A_RX	M
N	MRA5	VSS	NC	GVDD	VSS	MDT1	CRPEVDD	VSS	CRPEVDD	VSS	CRPEVDD	VSS	VDD	VSS	VDD	VSS	VDD	VSS	VDD	VSS	VDD	VSS	NC	NC	SXPVDD	SXPVSS	SD_B_TX	SD_B_TX	SXCVSS	SXCVDD	N
P	MCK2	MA10	NC	MA4	NC	MDT0	VSS	CRPEVDD	VSS	CRPEVDD	VSS	VDD	VSS	VDD	VSS	VDD	VSS	VDD	VSS	VDD	VSS	VDD	NC	NC	SD_IMP_CAL_RX	NC	SXPVDD	SXPVSS	SD_B_RX	SD_B_RX	P
R	MCK2	GVDD	MA0	VSS	GVDD	MBA0	GVDD	VSS	VDD	VSS	CRPEVDD	VSS	VDD	VSS	VDD	VSS	VDD	VSS	VDD	VSS	VDD	VSS	NC	NC	NC	NC	SD_C_TX	SD_C_TX	SXCVSS	SXCVDD	R
T	VSS	VSS	MCK1	MA1	MA3	MAPAR_OUT	VSS	GVDD	VSS	VDD	VSS	VDD	VSS	VDD	VSS	VDD	VSS	VDD	VSS	VDD	VSS	VDD	NC	NC	NC	NC	SXPVDD	SXPVSS	SD_C_RX	SD_C_RX	T
U	MAVDD	VSS	MCK1	GVDD	VSS	MBA1	GVDD	VSS	VDD	VSS	VDD	VSS	VDD	VSS	VDD	VSS	VDD	VSS	VDD	VSS	VDD	VSS	NC	NC	NC	NC	SD_D_TX	SD_D_TX	SXCVSS	SXCVDD	U
V	MVREF	VSS	MA8	MA2	MA6	MCKE1	VSS	GVDD	VSS	VDD	VSS	VDD	VSS	VDD	VSS	VDD	VSS	VDD	VSS	VDD	VSS	VDD	NC	NC	NC	NC	NC	NC	SD_D_RX	SD_D_RX	V
W	VSS	VSS	MA5	VSS	GVDD	MMD1C1	GVDD	VSS	VDD	VSS	M3VDD	VSS	M3VDD	VSS	M3VDD	VSS	CPRIVDD	VSS	VDD	VSS	VDD	VSS	NC	NC	NC	SD_PLL1_AVDD	SD_PLL1_AGND	NC	SXCVSS	SXCVDD	W
Y	MA11	MA9	MA12	MA7	NC	MMD1C0	VSS	GVDD	VSS	VDD	VSS	M3VDD	VSS	M3VDD	VSS	CPRIVDD	VSS	CPRIVDD	VSS	CPRIVDD	VSS	CPRIVDD	NC	NC	NC	NC	NC	NC	SD_REF_CLK1	SD_REF_CLK1	Y
AA	MDQ58	VSS	MA14	GVDD	VSS	MA15	MCKE0	VSS	GVDD	VSS	M3VDD	VSS	M3VDD	VSS	CPRIVDD	VSS	CPRIVDD	VSS	CPRIVDD	VSS	CPRIVDD	NC	NC	NC	NC	SD_IMP_CAL_TX	NC	NC	SD_E_TX	SD_E_TX	AA
AB	MDQ58	MDM8	MECC2	MECC1	NC	MAPAR_IN	MBA2	MDQ2	MDQ1	MDQ0	VSS	M3VDD	VSS	M3VDD	VSS	CPRIVDD	VSS	CPRIVDD	VSS	CPRIVDD	NC	NC	NC	NC	NC	NC	SXPVDD	SXPVSS	SD_E_RX	SD_E_RX	AB
AC	VSS	GVDD	MECC4	VSS	GVDD	MDQ25	VSS	GVDD	MDQ3	VSS	GVDD	VSS	M3VDD	VSS	CPRIVDD	VSS	NC	NC	NC	NC	NC	NC	NC	NC	NC	NC	SD_F_TX	SD_F_TX	SXCVSS	SXCVDD	AC
AD	MECC7	MECC6	MECC0	MECC5	MECC3	MDQ24	MDM0	MDQ50	MDQ50	MDQ4	MDQ6	VSS	VSS	VSS	VSS	VSS	NC	SD_PLL2_AVDD	NC	NC	NC	NC	NC	NC	NC	SXPVDD	SXPVSS	SD_F_RX	SD_F_RX	AD	
AE	MDQ52	VSS	MDQ18	GVDD	VSS	MDQ29	GVDD	VSS	MDQ5	GVDD	VSS	MDQ9	VSS	VSS	VSS	VSS	NC	SD_PLL2_AGND	NC	SD_I_TX	SXPVDD	SD_I_TX	SXPVDD	NC	SD_G_TX	SD_G_TX	SXCVSS	SXCVDD	AE		
AF	MDQ52	MDQ17	MDQ21	MDQ16	MDQ30	MDQ27	MDQ28	MDQ7	MDQ14	MDQ11	MDQ8	MDQ10	VSS	VSS	VSS	VSS	NC	NC	NC	SD_I_TX	SXPVSS	SD_I_TX	SXPVSS	NC	NC	SXPVDD	SXPVSS	SD_G_RX	SD_G_RX	AF	
AG	VSS	GVDD	MDQ22	VSS	GVDD	MDQ26	VSS	GVDD	MDQ13	VSS	GVDD	MDQ12	VSS	VSS	VSS	VSS	NC	SXCVSS	SD_REF_CLK2	SXCVSS	SD_I_RX	SXCVSS	SD_I_RX	SXCVSS	SD_H_TX	SD_H_TX	SXCVSS	SXCVDD	AG		
AH	MDQ20	MDQ19	MDQ23	MDM2	MDQ53	MDQ53	MDM3	MDQ31	MDQ51	MDQ51	MDQ15	MDM1	VSS	PLLO_AVDD	PLL1_AVDD	PLL2_AVDD	NC	SXCVDD	SD_REF_CLK2	SXCVDD	SD_I_RX	SXCVDD	SD_I_RX	SXCVDD	SXPVDD	SXPVSS	SD_H_RX	SD_H_RX	AH		
	1	2	3	4	5	6	7	8	9	10	11	12	13	14	15	16	17	18	19	20	21	22	23	24	25	26	27	28			

Figure 2. MSC8157 FC-PBGA Package, Top View

**NOTE**

See [Figure 31](#) as a reference for correct ball grid layout.

## 2.2 Signal Lists

[Table 1](#) presents the signal list sorted by ball number. [Table 2](#) presents the signal list by signal name. When designing a board, make sure that the power rail for each signal is appropriately considered. The specified power rail must be tied to the voltage level specified in this document if any of the related signal functions are used (active)

**NOTE**

The information in [Table 1](#) distinguishes among three concepts. First, the power pins are the balls of the device package used to supply specific power levels for different device subsystems (as opposed to signals). Second, the power rails are the electrical lines on the board that transfer power from the voltage regulators to the device. They are indicated here as the reference power rails for signal lines; therefore, the actual power inputs are listed as N/A with regard to the power rails. Third, symbols used in these tables are the names for the voltage levels (absolute, recommended, and so on) and not the power supplies themselves.

**Table 1. Signal List by Ball Number**

Ball Number	Signal Name <sup>1,2</sup>	Pin Type <sup>3</sup>	Power Rail Name
A2	VSS	Ground	N/A
A3	MDQ57	I/O	GVDD
A4	GVDD	Power	N/A
A5	VSS	Ground	N/A
A6	MDQ63	I/O	GVDD
A7	GVDD	Power	N/A
A8	NC	Non-user	N/A
A9	NC	Non-user	N/A
A10	NC	Non-user	N/A
A11	NC	Non-user	N/A
A12	NC	Non-user	N/A
A13	CLKOUT	O	QVDD
A14	EE0	I	QVDD
A15	VSS	Ground	N/A
A16	MCLKIN (optional)	I	QVDD
A17	VSS	Ground	N/A
A18	CLKIN	I	QVDD
A19	VSS	Ground	N/A
A20	GPIO29/UART_TXD/CP_LOS2	I/O	NVDD
A21	GPIO31/I2C_SDA	I/O	NVDD
A22	GE1_TX_CTL	O	NVDD

Table 1. Signal List by Ball Number (continued)

Ball Number	Signal Name <sup>1,2</sup>	Pin Type <sup>3</sup>	Power Rail Name
A23	GE1_GTX_CLK	O	NVDD
A24	GE1_TD0	O	NVDD
A25	GE1_TX_CLK	I	NVDD
A26	GE1_TD2	O	NVDD
A27	GE1_TD1	O	NVDD
A28	GE1_TD3	O	NVDD
B1	MDQ60	I/O	GVDD
B2	MDQ59	I/O	GVDD
B3	MDQS7	I/O	GVDD
B4	MDQS7	I/O	GVDD
B5	MDQ62	I/O	GVDD
B6	MDQ58	I/O	GVDD
B7	MDQ56	I/O	GVDD
B8	NC	Non-user	N/A
B9	VSS	Ground	N/A
B10	NC	Non-user	N/A
B11	VSS	Ground	N/A
B12	NC	Non-user	N/A
B13	VSS	Ground	N/A
B14	TDO	O	QVDD
B15	TMS	I	QVDD
B16	VSS	Ground	N/A
B17	VSS	Ground	N/A
B18	VSS	Ground	N/A
B19	VSS	Ground	N/A
B20	GE2_TX_CLK	I	NVDD
B21	VSS	Ground	N/A
B22	VSS	Non-user	N/A
B23	VSS	Ground	N/A
B24	GPIO25/TMR2/RCW_SRC1	I/O	NVDD
B25	VSS	Ground	N/A
B26	GE_MDC	O	NVDD
B27	VSS	Ground	N/A
B28	GPIO18/SPI_MOSI/CP_LOS4	I/O	NVDD

Table 1. Signal List by Ball Number (continued)

Ball Number	Signal Name <sup>1,2</sup>	Pin Type <sup>3</sup>	Power Rail Name
C1	VSS	Ground	N/A
C2	GVDD	Power	N/A
C3	MDQ61	I/O	GVDD
C4	VSS	Ground	N/A
C5	GVDD	Power	N/A
C6	MDM7	O	GVDD
C7	VSS	Ground	N/A
C8	NC	Non-user	N/A
C9	NC	Non-user	N/A
C10	NC	Non-user	N/A
C11	NC	Non-user	N/A
C12	NC	Non-user	N/A
C13	NC	Non-user	N/A
C14	EE1	O	QVDD
C15	NC	Non-user	N/A
C16	DFT_TEST	I	QVDD
C17	$\overline{\text{PORESET}}$	I	QVDD
C18	VSS	Ground	N/A
C19	GPIO15/DDN0/IRQ15/RC15	I/O	NVDD
C20	GE2_TD2/CP_LOS3	I/O	NVDD
C21	GE2_GTX_CLK/CP_LOS4	I/O	NVDD
C22	GE2_TX_CTL	O	NVDD
C23	GE2_TD1	O	NVDD
C24	GE2_TD0	O	NVDD
C25	GPIO30/I2C_SCL	I/O	NVDD
C26	GPIO20/SPI_SL/CP_LOS6	I/O	NVDD
C27	GE_MDIO	I/O	NVDD
C28	GPIO21/TMR6	I/O	NVDD
D1	MDQ49	I/O	GVDD
D2	MDQ48	I/O	GVDD
D3	$\overline{\text{MDQS6}}$	I/O	GVDD
D4	MDQS6	I/O	GVDD
D5	MDQ50	I/O	GVDD
D6	MDQ51	I/O	GVDD

Table 1. Signal List by Ball Number (continued)

Ball Number	Signal Name <sup>1,2</sup>	Pin Type <sup>3</sup>	Power Rail Name
D7	MDQ52	I/O	GVDD
D8	NC	Non-user	N/A
D9	VSS	Ground	N/A
D10	NC	Non-user	N/A
D11	VSS	Ground	N/A
D12	NC	Non-user	N/A
D13	VSS	Ground	N/A
D14	NC	Non-user	N/A
D15	NMI	I	QVDD
D16	VSS	Ground	N/A
D17	HRESET_IN	I	QVDD
D18	VSS	Ground	N/A
D19	VSS	Non-user	N/A
D20	GPIO13/IRQ13/RC13	I/O	NVDD
D21	NVDD	Power	N/A
D22	GE2_TD3/CP_LOS5	I/O	NVDD
D23	VSS	Ground	N/A
D24	GPIO5/IRQ5/RC5/CP_SYNC4	I/O	NVDD
D25	NVDD	Power	N/A
D26	GPIO16/TMR5/RC16	I/O	NVDD
D27	VSS'	Ground	N/A
D28	GPIO10/IRQ10/RC10	I/O	NVDD
E1	MDQ53	I/O	GVDD
E2	VSS	Ground	N/A
E3	MDQ55	I/O	GVDD
E4	GVDD	Power	N/A
E5	VSS	Ground	N/A
E6	MDQ54	I/O	GVDD
E7	GVDD	Power	N/A
E8	VSS	Ground	N/A
E9	NC	Non-user	N/A
E10	NC	Non-user	N/A
E11	NC	Non-user	N/A
E12	NC	Non-user	N/A



Table 1. Signal List by Ball Number (continued)

Ball Number	Signal Name <sup>1,2</sup>	Pin Type <sup>3</sup>	Power Rail Name
E13	NC	Non-user	N/A
E14	NC	Non-user	N/A
E15	INT_OUT/CP_TX_INT	O	QVDD
E16	HRESET	I/O	QVDD
E17	TCK	I	QVDD
E18	VSS	Ground	N/A
E19	NVDD	Power	N/A
E20	GE2_RD3/CP_LOS2	I	NVDD
E21	VSS	Ground	N/A
E22	VSS	Non-user	N/A
E23	NVDD	Power	N/A
E24	GPIO27/TMR4/RCW_SRC0	I/O	NVDD
E25	VSS	Ground	N/A
E26	GPIO0/IRQ0/RC0/CP_SYNC1	I/O	NVDD
E27	GPIO17/SPI_SCK/CP_LOS3	I/O	NVDD
E28	GPIO1/IRQ1/RC1/CP_SYNC2	I/O	NVDD
F1	MDQ40	I/O	GVDD
F2	MDQ41	I/O	GVDD
F3	MDQS5	I/O	GVDD
F4	MDQS5	I/O	GVDD
F5	MDQ43	I/O	GVDD
F6	MDQ47	I/O	GVDD
F7	MDM6	O	GVDD
F8	VDD	Power	N/A
F9	VSS	Ground	N/A
F10	VDD	Power	N/A
F11	NC	Non-user	N/A
F12	NC	Non-user	N/A
F13	VSS	Ground	N/A
F14	NC	Non-user	N/A
F15	NMI_OUT/CP_RX_INT	O	QVDD
F16	VSS	Ground	N/A
F17	TDI	I	QVDD
F18	VSS	Ground	N/A

Table 1. Signal List by Ball Number (continued)

Ball Number	Signal Name <sup>1,2</sup>	Pin Type <sup>3</sup>	Power Rail Name
F19	GE2_RD2/CP_LOS1	I	NVDD
F20	GE2_RX_CTL	I	NVDD
F21	GE2_RD0/CP_LOS6	I	NVDD
F22	GE2_RX_CLK	I	NVDD
F23	GE2_RD1	I	NVDD
F24	GPIO26/TMR3	I/O	NVDD
F25	GPIO6/IRQ6/RC6/CP_SYNC5	I/O	NVDD
F26	GPIO22	I/O	NVDD
F27	GPIO23/TMR0/BOOT_SPI_SL	I/O	NVDD
F28	GPIO8/IRQ8/RC8	I/O	NVDD
G1	VSS	Ground	N/A
G2	GVDD	Power	N/A
G3	MDM5	O	GVDD
G4	VSS	Ground	N/A
G5	GVDD	Power	N/A
G6	MDQ46	I/O	GVDD
G7	VDD	Power	N/A
G8	VSS	Ground	N/A
G9	VDD	Power	N/A
G10	VSS	Ground	N/A
G11	NC	Non-user	N/A
G12	NC	Non-user	N/A
G13	NC	Non-user	N/A
G14	NC	Non-user	N/A
G15	QVDD	Power	N/A
G16	STOP_BS	I	QVDD
G17	TRST	I	QVDD
G18	VSS	Ground	N/A
G19	GPIO28/UART_RXD/CP_LOS1	I/O	NVDD
G20	GE1_RD3	I	NVDD
G21	GE1_RD2	I	NVDD
G22	GE1_RX_CLK	I	NVDD
G23	VSS	Ground	N/A
G24	GE1_RX_CTL	I	NVDD

Table 1. Signal List by Ball Number (continued)

Ball Number	Signal Name <sup>1,2</sup>	Pin Type <sup>3</sup>	Power Rail Name
G25	NVDD	Power	N/A
G26	GPIO19/SPI_MISO/CP_LOS5	I/O	NVDD
G27	VSS	Ground	N/A
G28	GPIO11/ $\overline{\text{IRQ11}}$ /RC11	I/O	NVDD
H1	MDQ38	I/O	GVDD
H2	$\overline{\text{MDQS4}}$	I/O	GVDD
H3	MDQS4	I/O	GVDD
H4	MDQ44	I/O	GVDD
H5	MDQ45	I/O	GVDD
H6	MDQ42	I/O	GVDD
H7	VSS	Ground	N/A
H8	VDD	Power	N/A
H9	VSS	Ground	N/A
H10	VDD	Power	N/A
H11	VSS	Ground	N/A
H12	VSS	Non-user	N/A
H13	NC	Non-user	N/A
H14	QVDD	Power	N/A
H15	VSS	Ground	N/A
H16	VDD	Power	N/A
H17	VSS	Ground	N/A
H18	VDD	Power	N/A
H19	VSS	Ground	N/A
H20	NVDD	Power	N/A
H21	VSS	Ground	N/A
H22	GE1_RD0	I	NVDD
H23	NVDD	Power	N/A
H24	GE1_RD1	I	NVDD
H25	VSS	Ground	N/A
H26	GPIO14/ $\overline{\text{DRQ0}}$ / $\overline{\text{IRQ14}}$ /RC14	I/O	NVDD
H27	NVDD	Power	N/A
H28	GPIO12/ $\overline{\text{IRQ12}}$ /RC12	I/O	NVDD
J1	MDQ37	I/O	GVDD
J2	VSS	Ground	N/A

Table 1. Signal List by Ball Number (continued)

Ball Number	Signal Name <sup>1,2</sup>	Pin Type <sup>3</sup>	Power Rail Name
J3	MDQ35	I/O	GVDD
J4	GVDD	Power	N/A
J5	MDQ33	I/O	GVDD
J6	MDQ36	I/O	GVDD
J7	VDD	Power	N/A
J8	VSS	Ground	N/A
J9	VDD	Power	N/A
J10	VSS	Ground	N/A
J11	VDD	Power	N/A
J12	VSS	Ground	N/A
J13	VDD	Power	N/A
J14	VSS	Ground	N/A
J15	VDD	Power	N/A
J16	VSS	Ground	N/A
J17	VDD	Power	N/A
J18	VSS	Ground	N/A
J19	VDD	Power	N/A
J20	VSS	Ground	N/A
J21	NVDD	Power	N/A
J22	GPIO24/TMR1/RCW_SRC2	I/O	NVDD
J23	GPIO9/IRQ9/RC9	I/O	NVDD
J24	RCW_LSEL0/RC17	I/O	NVDD
J25	RCW_LSEL3/RC20	I/O	NVDD
J26	RCW_LSEL2/RC19	I/O	NVDD
J27	RC21	I	NVDD
J28	GPIO3/DRQ1/IRQ3/RC3	I/O	NVDD
K1	MCAS	O	GVDD
K2	MCS0	O	GVDD
K3	MCS1	O	GVDD
K4	MDQ39	I/O	GVDD
K5	MDQ32	I/O	GVDD
K6	MDQ34	I/O	GVDD
K7	VSS	Ground	N/A
K8	VDD	Power	N/A

Table 1. Signal List by Ball Number (continued)

Ball Number	Signal Name <sup>1,2</sup>	Pin Type <sup>3</sup>	Power Rail Name
K9	VSS	Ground	N/A
K10	VDD	Power	N/A
K11	VSS	Ground	N/A
K12	VDD	Power	N/A
K13	VSS	Ground	N/A
K14	VDD	Power	N/A
K15	VSS	Ground	N/A
K16	VDD	Power	N/A
K17	VSS	Ground	N/A
K18	VDD	Power	N/A
K19	VSS	Ground	N/A
K20	VDD	Power	N/A
K21	VSS	Ground	N/A
K22	GPIO4/DDN1/IRQ4/RC4	I/O	NVDD
K23	VSS	Ground	N/A
K24	RCW_LSEL1/RC18	I/O	NVDD
K25	NVDD	Power	N/A
K26	GPIO7/IRQ7/RC7/CP_SYNC6	I/O	NVDD
K27	VSS	Ground	N/A
K28	GPIO2/IRQ2/RC2/CP_SYNC3	I/O	NVDD
L1	VSS	Ground	N/A
L2	GVDD	Power	N/A
L3	NC	Non-user	N/A
L4	VSS	Ground	N/A
L5	GVDD	Power	N/A
L6	MDM4	O	GVDD
L7	VDD	Power	N/A
L8	VSS	Ground	N/A
L9	VDD	Power	N/A
L10	VSS	Ground	N/A
L11	VDD	Power	N/A
L12	VSS	Ground	N/A
L13	VDD	Power	N/A
L14	VSS	Ground	N/A

Table 1. Signal List by Ball Number (continued)

Ball Number	Signal Name <sup>1,2</sup>	Pin Type <sup>3</sup>	Power Rail Name
L15	VDD	Power	N/A
L16	VSS	Ground	N/A
L17	VDD	Power	N/A
L18	VSS	Ground	N/A
L19	VDD	Power	N/A
L20	VSS	Ground	N/A
L21	NVDD	Power	N/A
L22	NC	NC	N/A
L23	NC	NC	N/A
L24	VSS	Non-user	N/A
L25	VSS	Non-user	N/A
L26	VSS	Non-user	N/A
L27	SXCVSS	Ground	N/A
L28	SXCVDD	Power	N/A
M1	$\overline{\text{MCK0}}$	O	GVDD
M2	MCK0	O	GVDD
M3	MA13	O	GVDD
M4	$\overline{\text{MWE}}$	O	GVDD
M5	NC	Non-user	N/A
M6	NC	Non-user	N/A
M7	VSS	Ground	N/A
M8	VDD	Power	N/A
M9	VSS	Ground	N/A
M10	VDD	Power	N/A
M11	VSS	Ground	N/A
M12	VDD	Power	N/A
M13	VSS	Ground	N/A
M14	VDD	Power	N/A
M15	VSS	Ground	N/A
M16	VDD	Power	N/A
M17	VSS	Ground	N/A
M18	VDD	Power	N/A
M19	VSS	Ground	N/A
M20	VDD	Power	N/A

Table 1. Signal List by Ball Number (continued)

Ball Number	Signal Name <sup>1,2</sup>	Pin Type <sup>3</sup>	Power Rail Name
M21	NC	NC	N/A
M22	NC	NC	N/A
M23	SD_A_TX	O	SXPVDD
M24	$\overline{\text{SD\_A\_TX}}$	O	SXPVDD
M25	SXPVDD	Power	N/A
M26	SXPVSS	Ground	N/A
M27	$\overline{\text{SD\_A\_RX}}$	I	SXCVDD
M28	SD_A_RX	I	SXCVDD
N1	$\overline{\text{MRAS}}$	O	GVDD
N2	VSS	Ground	N/A
N3	NC	Non-user	N/A
N4	GVDD	Power	N/A
N5	VSS	Ground	N/A
N6	MODT1	O	GVDD
N7	CRPEVDD	Power	N/A
N8	VSS	Ground	N/A
N9	CRPEVDD	Power	N/A
N10	VSS	Ground	N/A
N11	CRPEVDD	Power	N/A
N12	VSS	Ground	N/A
N13	VDD	Power	N/A
N14	VSS	Ground	N/A
N15	VDD	Power	N/A
N16	VSS	Ground	N/A
N17	VDD	Power	N/A
N18	VSS	Ground	N/A
N19	VDD	Power	N/A
N20	VSS	Ground	N/A
N21	NC	NC	N/A
N22	NC	NC	N/A
N23	SXPVDD	Power	N/A
N24	SXPVSS	Ground	N/A
N25	SD_B_TX	O	SXPVDD
N26	$\overline{\text{SD\_B\_TX}}$	O	SXPVDD

Table 1. Signal List by Ball Number (continued)

Ball Number	Signal Name <sup>1,2</sup>	Pin Type <sup>3</sup>	Power Rail Name
N27	SXCVSS	Ground	N/A
N28	SXCVDD	Power	N/A
P1	MCK2	O	GVDD
P2	MA10	O	GVDD
P3	NC	Non-user	N/A
P4	MA4	O	GVDD
P5	NC	Non-user	N/A
P6	MODT0	O	GVDD
P7	VSS	Ground	N/A
P8	CRPEVDD	Power	N/A
P9	VSS	Ground	N/A
P10	CRPEVDD	Power	N/A
P11	VSS	Ground	N/A
P12	VDD	Power	N/A
P13	VSS	Ground	N/A
P14	VDD	Power	N/A
P15	VSS	Ground	N/A
P16	VDD	Power	N/A
P17	VSS	Ground	N/A
P18	VDD	Power	N/A
P19	VSS	Ground	N/A
P20	VDD	Power	N/A
P21	NC	NC	N/A
P22	SD_IMP_CAL_RX	I	SXCVDD
P23	NC	NC	N/A
P24	NC	NC	N/A
P25	SXPVDD	Power	N/A
P26	SXPVSS	Ground	N/A
P27	SD_B_RX	I	SXCVDD
P28	SD_B_RX	I	SXCVDD
R1	MCK2	O	GVDD
R2	GVDD	Power	N/A
R3	MA0	O	GVDD
R4	VSS	Ground	N/A



Table 1. Signal List by Ball Number (continued)

Ball Number	Signal Name <sup>1,2</sup>	Pin Type <sup>3</sup>	Power Rail Name
R5	GVDD	Power	N/A
R6	MBA0	O	GVDD
R7	GVDD	Power	N/A
R8	VSS	Ground	N/A
R9	VDD	Power	N/A
R10	VSS	Ground	N/A
R11	CRPEVDD	Power	N/A
R12	VSS	Ground	N/A
R13	VDD	Power	N/A
R14	VSS	Ground	N/A
R15	VDD	Power	N/A
R16	VSS	Ground	N/A
R17	VDD	Power	N/A
R18	VSS	Ground	N/A
R19	VDD	Power	N/A
R20	VSS	Ground	N/A
R21	NC	NC	N/A
R22	NC	NC	N/A
R23	NC	NC	N/A
R24	NC	NC	N/A
R25	SD_C_TX	O	SXPVDD
R26	$\overline{\text{SD\_C\_TX}}$	O	SXPVDD
R27	SXCVSS	Ground	N/A
R28	SXCVDD	Power	N/A
T1	VSS	Ground	N/A
T2	VSS	Ground	N/A
T3	$\overline{\text{MCK1}}$	O	GVDD
T4	MA1	O	GVDD
T5	MA3	O	GVDD
T6	MAPAR_OUT	O	GVDD
T7	VSS	Ground	N/A
T8	GVDD	Power	N/A
T9	VSS	Ground	N/A
T10	VDD	Power	N/A

Table 1. Signal List by Ball Number (continued)

Ball Number	Signal Name <sup>1,2</sup>	Pin Type <sup>3</sup>	Power Rail Name
T11	VSS	Ground	N/A
T12	VDD	Power	N/A
T13	VSS	Ground	N/A
T14	VDD	Power	N/A
T15	VSS	Ground	N/A
T16	VDD	Power	N/A
T17	VSS	Ground	N/A
T18	VDD	Power	N/A
T19	VSS	Ground	N/A
T20	VDD	Power	N/A
T21	NC	NC	N/A
T22	NC	Non-user	N/A
T23	NC	Non-user	N/A
T24	NC	NC	N/A
T25	SXPVDD	Power	N/A
T26	SXPVSS	Ground	N/A
T27	$\overline{\text{SD\_C\_RX}}$	I	SXCVDD
T28	SD_C_RX	I	SXCVDD
U1	MAVDD	Power	N/A
U2	VSS	Ground	N/A
U3	MCK1	O	GVDD
U4	GVDD	Power	N/A
U5	VSS	Ground	N/A
U6	MBA1	O	GVDD
U7	GVDD	Power	N/A
U8	VSS	Ground	N/A
U9	VDD	Power	N/A
U10	VSS	Ground	N/A
U11	VDD	Power	N/A
U12	VSS	Ground	N/A
U13	VDD	Power	N/A
U14	VSS	Ground	N/A
U15	VDD	Power	N/A
U16	VSS	Ground	N/A

Table 1. Signal List by Ball Number (continued)

Ball Number	Signal Name <sup>1,2</sup>	Pin Type <sup>3</sup>	Power Rail Name
U17	VDD	Power	N/A
U18	VSS	Ground	N/A
U19	VDD	Power	N/A
U20	VSS	Ground	N/A
U21	NC	NC	N/A
U22	NC	NC	N/A
U23	NC	NC	N/A
U24	NC	NC	N/A
U25	SD_D_TX	O	SXPVDD
U26	$\overline{\text{SD\_D\_TX}}$	O	SXPVDD
U27	SXCVSS	Ground	N/A
U28	SXCVDD	Power	N/A
V1	MVREF	Power	N/A
V2	VSS	Ground	N/A
V3	MA8	O	GVDD
V4	MA2	O	GVDD
V5	MA6	O	GVDD
V6	MCKE1	O	GVDD
V7	VSS	Ground	N/A
V8	GVDD	Power	N/A
V9	VSS	Ground	N/A
V10	VDD	Power	N/A
V11	VSS	Ground	N/A
V12	VDD	Power	N/A
V13	VSS	Ground	N/A
V14	VDD	Power	N/A
V15	VSS	Ground	N/A
V16	VDD	Power	N/A
V17	VSS	Ground	N/A
V18	VDD	Power	N/A
V19	VSS	Ground	N/A
V20	VDD	Power	N/A
V21	NC	NC	N/A
V22	NC	NC	N/A

Table 1. Signal List by Ball Number (continued)

Ball Number	Signal Name <sup>1,2</sup>	Pin Type <sup>3</sup>	Power Rail Name
V23	NC	NC	N/A
V24	NC	NC	N/A
V25	NC	NC	N/A
V26	NC	NC	N/A
V27	$\overline{\text{SD\_D\_RX}}$	I	SXCVDD
V28	SD_D_RX	I	SXCVDD
W1	VSS	Ground	N/A
W2	VSS	Ground	N/A
W3	MA5	O	GVDD
W4	VSS	Ground	N/A
W5	GVDD	Power	N/A
W6	MMDIC1	I/O	GVDD
W7	GVDD	Power	N/A
W8	VSS	Ground	N/A
W9	VDD	Power	N/A
W10	VSS	Ground	N/A
W11	M3VDD	Power	N/A
W12	VSS	Ground	N/A
W13	M3VDD	Power	N/A
W14	VSS	Ground	N/A
W15	M3VDD	Power	N/A
W16	VSS	Ground	N/A
W17	CPRIVDD	Power	N/A
W18	VSS	Ground	N/A
W19	VDD	Power	N/A
W20	VSS	Ground	N/A
W21	NC	NC	N/A
W22	NC	NC	N/A
W23	NC	NC	N/A
W24	SD_PLL1_AVDD	Power	N/A
W25	SD_PLL1_AGND	Ground	N/A
W26	NC	NC	N/A
W27	SXCVSS	Ground	N/A
W28	SXCVDD	Power	N/A

Table 1. Signal List by Ball Number (continued)

Ball Number	Signal Name <sup>1,2</sup>	Pin Type <sup>3</sup>	Power Rail Name
Y1	MA11	O	GVDD
Y2	MA9	O	GVDD
Y3	MA12	O	GVDD
Y4	MA7	O	GVDD
Y5	NC	Non-user	N/A
Y6	MMDIC0	I/O	GVDD
Y7	VSS	Ground	N/A
Y8	GVDD	Power	N/A
Y9	VSS	Ground	N/A
Y10	VDD	Power	N/A
Y11	VSS	Ground	N/A
Y12	M3VDD	Power	N/A
Y13	VSS	Ground	N/A
Y14	M3VDD	Power	N/A
Y15	VSS	Ground	N/A
Y16	CPRIVDD	Power	N/A
Y17	VSS	Ground	N/A
Y18	CPRIVDD	Power	N/A
Y19	VSS	Ground	N/A
Y20	VDD	Power	N/A
Y21	NC	NC	N/A
Y22	NC	NC	N/A
Y23	NC	NC	N/A
Y24	NC	NC	N/A
Y25	NC	NC	N/A
Y26	NC	NC	N/A
Y27	SD_REF_CLK1	I	SXCVDD
Y28	$\overline{\text{SD\_REF\_CLK1}}$	I	SXCVDD
AA1	MDQS8	I/O	GVDD
AA2	VSS	Ground	N/A
AA3	MA14	O	GVDD
AA4	GVDD	Power	N/A
AA5	VSS	Ground	N/A
AA6	MA15	O	GVDD

Table 1. Signal List by Ball Number (continued)

Ball Number	Signal Name <sup>1,2</sup>	Pin Type <sup>3</sup>	Power Rail Name
AA7	MCKE0	O	GVDD
AA8	VSS	Ground	N/A
AA9	GVDD	Power	N/A
AA10	VSS	Ground	N/A
AA11	M3VDD	Power	N/A
AA12	VSS	Ground	N/A
AA13	M3VDD	Power	N/A
AA14	VSS	Ground	N/A
AA15	CPRIVDD	Power	N/A
AA16	VSS	Ground	N/A
AA17	CPRIVDD	Power	N/A
AA18	VSS	Ground	N/A
AA19	CPRIVDD	Power	N/A
AA20	NC	NC	N/A
AA21	SD_IMP_CAL_TX	I	SXPVDD
AA22	NC	NC	N/A
AA23	NC	NC	N/A
AA24	NC	NC	N/A
AA25	SD_E_TX	O	SXPVDD
AA26	$\overline{\text{SD\_E\_TX}}$	O	SXPVDD
AA27	SXCVSS	Ground	N/A
AA28	SXCVDD	Power	N/A
AB1	$\overline{\text{MDQS8}}$	I/O	GVDD
AB2	MDM8	O	GVDD
AB3	MECC2	I/O	GVDD
AB4	MECC1	I/O	GVDD
AB5	NC	Non-user	N/A
AB6	MAPAR_IN	I	GVDD
AB7	MBA2	O	GVDD
AB8	MDQ2	I/O	GVDD
AB9	MDQ1	I/O	GVDD
AB10	MDQ0	I/O	GVDD
AB11	VSS	Ground	N/A
AB12	M3VDD	Power	N/A

**Table 1. Signal List by Ball Number (continued)**

Ball Number	Signal Name <sup>1,2</sup>	Pin Type <sup>3</sup>	Power Rail Name
AB13	VSS	Ground	N/A
AB14	M3VDD	Power	N/A
AB15	VSS	Ground	N/A
AB16	CPRIVDD	Power	N/A
AB17	VSS	Ground	N/A
AB18	CPRIVDD	Power	N/A
AB19	NC	NC	N/A
AB20	NC	Non-user	N/A
AB21	NC	NC	N/A
AB22	NC	NC	N/A
AB23	NC	NC	N/A
AB24	NC	NC	N/A
AB25	SXPVDD	Power	N/A
AB26	SXPVSS	Ground	N/A
AB27	$\overline{SD\_E\_RX}$	I	SXCVDD
AB28	SD_E_RX	I	SXCVDD
AC1	VSS	Ground	N/A
AC2	GVDD	Power	N/A
AC3	MECC4	I/O	GVDD
AC4	VSS	Ground	N/A
AC5	GVDD	Power	N/A
AC6	MDQ25	I/O	GVDD
AC7	VSS	Ground	N/A
AC8	GVDD	Power	N/A
AC9	MDQ3	I/O	GVDD
AC10	VSS	Ground	N/A
AC11	GVDD	Power	N/A
AC12	VSS	Ground	N/A
AC13	M3VDD	Power	N/A
AC14	VSS	Ground	N/A
AC15	CPRIVDD	Power	N/A
AC16	VSS	Ground	N/A
AC17	NC	NC	N/A
AC18	NC	NC	N/A

Table 1. Signal List by Ball Number (continued)

Ball Number	Signal Name <sup>1,2</sup>	Pin Type <sup>3</sup>	Power Rail Name
AC19	NC	NC	N/A
AC20	NC	Non-user	N/A
AC21	NC	NC	N/A
AC22	NC	NC	N/A
AC23	NC	NC	N/A
AC24	NC	NC	N/A
AC25	SD_F_TX	O	SXPVDD
AC26	$\overline{\text{SD\_F\_TX}}$	O	SXPVDD
AC27	SXCVSS	Ground	N/A
AC28	SXCVDD	Power	N/A
AD1	MECC7	I/O	GVDD
AD2	MECC6	I/O	GVDD
AD3	MECC0	I/O	GVDD
AD4	MECC5	I/O	GVDD
AD5	MECC3	I/O	GVDD
AD6	MDQ24	I/O	GVDD
AD7	MDM0	O	GVDD
AD8	$\overline{\text{MDQS0}}$	I/O	GVDD
AD9	MDQS0	I/O	GVDD
AD10	MDQ4	I/O	GVDD
AD11	MDQ6	I/O	GVDD
AD12	VSS	Non-user	N/A
AD13	VSS	Non-user	N/A
AD14	VSS	Non-user	N/A
AD15	VSS	Ground	N/A
AD16	VSS	Ground	N/A
AD17	NC	NC	N/A
AD18	SD_PLL2_AVDD	Power	N/A
AD19	NC	NC	N/A
AD20	NC	NC	N/A
AD21	NC	NC	N/A
AD22	NC	NC	N/A
AD23	NC	NC	N/A
AD24	NC	NC	N/A



Table 1. Signal List by Ball Number (continued)

Ball Number	Signal Name <sup>1,2</sup>	Pin Type <sup>3</sup>	Power Rail Name
AD25	SXPVDD	Power	N/A
AD26	SXPVSS	Ground	N/A
AD27	SD_F_RX	I	SXCVDD
AD28	SD_F_RX	I	SXCVDD
AE1	MDQS2	I/O	GVDD
AE2	VSS	Ground	N/A
AE3	MDQ18	I/O	GVDD
AE4	GVDD	Power	N/A
AE5	VSS	Ground	N/A
AE6	MDQ29	I/O	GVDD
AE7	GVDD	Power	N/A
AE8	VSS	Ground	N/A
AE9	MDQ5	I/O	GVDD
AE10	GVDD	Power	N/A
AE11	VSS	Ground	N/A
AE12	MDQ9	I/O	GVDD
AE13	VSS	Non-user	N/A
AE14	VSS	Ground	N/A
AE15	VSS	Ground	N/A
AE16	VSS	Ground	N/A
AE17	NC	NC	N/A
AE18	SD_PLL2_AGND	Ground	N/A
AE19	NC	NC	N/A
AE20	SD_J_TX	O	SXPVDD
AE21	SXPVDD	Power	N/A
AE22	SD_I_TX	O	SXPVDD
AE23	SXPVDD	Power	N/A
AE24	NC	NC	N/A
AE25	SD_G_TX	O	SXPVDD
AE26	SD_G_TX	O	SXPVDD
AE27	SXCVSS	Ground	N/A
AE28	SXCVDD	Power	N/A
AF1	MDQS2	I/O	GVDD
AF2	MDQ17	I/O	GVDD

Table 1. Signal List by Ball Number (continued)

Ball Number	Signal Name <sup>1,2</sup>	Pin Type <sup>3</sup>	Power Rail Name
AF3	MDQ21	I/O	GVDD
AF4	MDQ16	I/O	GVDD
AF5	MDQ30	I/O	GVDD
AF6	MDQ27	I/O	GVDD
AF7	MDQ28	I/O	GVDD
AF8	MDQ7	I/O	GVDD
AF9	MDQ14	I/O	GVDD
AF10	MDQ11	I/O	GVDD
AF11	MDQ8	I/O	GVDD
AF12	MDQ10	I/O	GVDD
AF13	VSS	Non-user	N/A
AF14	VSS	Ground	N/A
AF15	VSS	Ground	N/A
AF16	VSS	Ground	N/A
AF17	NC	NC	N/A
AF18	NC	NC	N/A
AF19	NC	NC	N/A
AF20	$\overline{\text{SD\_J\_TX}}$	O	SXPVDD
AF21	SXPVSS	Ground	N/A
AF22	$\overline{\text{SD\_I\_TX}}$	O	SXPVDD
AF23	SXPVSS	Ground	N/A
AF24	NC	NC	N/A
AF25	SXPVDD	Power	N/A
AF26	SXPVSS	Ground	N/A
AF27	$\overline{\text{SD\_G\_RX}}$	I	SXCVDD
AF28	SD_G_RX	I	SXCVDD
AG1	VSS	Ground	N/A
AG2	GVDD	Power	N/A
AG3	MDQ22	I/O	GVDD
AG4	VSS	Ground	N/A
AG5	GVDD	Power	N/A
AG6	MDQ26	I/O	GVDD
AG7	VSS	Ground	N/A
AG8	GVDD	Power	N/A

Table 1. Signal List by Ball Number (continued)

Ball Number	Signal Name <sup>1,2</sup>	Pin Type <sup>3</sup>	Power Rail Name
AG9	MDQ13	I/O	GVDD
AG10	VSS	Ground	N/A
AG11	GVDD	Power	N/A
AG12	MDQ12	I/O	GVDD
AG13	VSS	Ground	N/A
AG14	VSS	Ground	N/A
AG15	VSS	Ground	N/A
AG16	VSS	Ground	N/A
AG17	NC	NC	N/A
AG18	SXCVSS	Ground	N/A
AG19	$\overline{\text{SD\_REF\_CLK2}}$	I	SXCVDD
AG20	SXCVSS	Ground	N/A
AG21	$\overline{\text{SD\_J\_RX}}$	I	SXCVDD
AG22	SXCVSS	Ground	N/A
AG23	$\overline{\text{SD\_I\_RX}}$	I	SXCVDD
AG24	SXCVSS	Ground	N/A
AG25	SD_H_TX	O	SXPVDD
AG26	$\overline{\text{SD\_H\_TX}}$	O	SXPVDD
AG27	SXCVSS	Ground	N/A
AG28	SXCVDD	Power	N/A
AH1	MDQ20	I/O	GVDD
AH2	MDQ19	I/O	GVDD
AH3	MDQ23	I/O	GVDD
AH4	MDM2	O	GVDD
AH5	$\overline{\text{MDQS3}}$	I/O	GVDD
AH6	MDQS3	I/O	GVDD
AH7	MDM3	O	GVDD
AH8	MDQ31	I/O	GVDD
AH9	$\overline{\text{MDQS1}}$	I/O	GVDD
AH10	MDQS1	I/O	GVDD
AH11	MDQ15	I/O	GVDD
AH12	MDM1	O	GVDD
AH13	VSS	Ground	N/A
AH14	PLL0_AVDD	Power	N/A

**Table 1. Signal List by Ball Number (continued)**

Ball Number	Signal Name <sup>1,2</sup>	Pin Type <sup>3</sup>	Power Rail Name
AH15	PLL1_AVDD	Power	N/A
AH16	PLL2_AVDD	Power	N/A
AH17	NC	NC	N/A
AH18	SXCVDD	Power	N/A
AH19	SD_REF_CLK2	I	SXCVDD
AH20	SXCVDD	Power	N/A
AH21	SD_J_RX	I	SXCVDD
AH22	SXCVDD	Power	N/A
AH23	SD_I_RX	I	SXCVDD
AH24	SXCVDD	Power	N/A
AH25	SXPVDD	Power	N/A
AH26	SXPVSS	Ground	N/A
AH27	$\overline{\text{SD\_H\_RX}}$	I	SXCVDD
AH28	SD_H_RX	I	SXCVDD

- Notes:**
1. Signal function during power-on reset is determined by the RCW source type. Selection of RapidIO, SGMII, CPRI, and PCI Express functionality during normal operation is configured by the RCW bit values. Selection of the GPIO function and other functions is done by GPIO register setup. For signals with GPIO functionality, the open-drain and internal 20 K $\Omega$  pull-up resistor can be configured by GPIO register programming. For configuration details, see the *GPIO* chapter in the *MSC8157 Reference Manual*.
  2. NC signals should be disconnected for compatibility with future revisions of the device. Non-user signals are reserved for manufacturing and test purposes only. The assigned signal name is used to indicate whether the signal must be unconnected (Reserved), pulled down (VSS or SXCVSS), or pulled up (VDD).
  3. Pin types are: Ground = all VSS connections; Power = all VDD connections; I = Input; O = Output; I/O = Input/Output; NC = not connected; non-user = connect as specified under Signal Name.
  4. Connect power inputs to the power supplies via external filters. See the *MSC8157 Design Checklist* (AN4110) for details.

**Table 2. Signal List by Primary Signal Name**

Ball Number	Signal Name <sup>1,2</sup>	Pin Type <sup>3</sup>	Power Rail Name
A18	CLKIN	I	QVDD
A13	CLKOUT	O	QVDD
AA15	CPRIVDD	Power	N/A
AA17	CPRIVDD	Power	N/A
AA19	CPRIVDD	Power	N/A
AB16	CPRIVDD	Power	N/A
AB18	CPRIVDD	Power	N/A
AC15	CPRIVDD	Power	N/A
W17	CPRIVDD	Power	N/A
Y16	CPRIVDD	Power	N/A

Table 2. Signal List by Primary Signal Name (continued)

Ball Number	Signal Name <sup>1,2</sup>	Pin Type <sup>3</sup>	Power Rail Name
Y18	CPRIVDD	Power	N/A
N11	CRPEVDD	Power	N/A
N7	CRPEVDD	Power	N/A
N9	CRPEVDD	Power	N/A
P10	CRPEVDD	Power	N/A
P8	CRPEVDD	Power	N/A
R11	CRPEVDD	Power	N/A
C16	DFT_TEST	I	QVDD
A14	EE0	I	QVDD
C14	EE1	O	QVDD
B26	GE_MDC	O	NVDD
C27	GE_MDIO	I/O	NVDD
A23	GE1_GTX_CLK	O	NVDD
H22	GE1_RD0	I	NVDD
H24	GE1_RD1	I	NVDD
G21	GE1_RD2	I	NVDD
G20	GE1_RD3	I	NVDD
G22	GE1_RX_CLK	I	NVDD
G24	GE1_RX_CTL	I	NVDD
A24	GE1_TD0	O	NVDD
A27	GE1_TD1	O	NVDD
A26	GE1_TD2	O	NVDD
A28	GE1_TD3	O	NVDD
A25	GE1_TX_CLK	I	NVDD
A22	GE1_TX_CTL	O	NVDD
C21	GE2_GTX_CLK/CP_LOS4	I/O	NVDD
F21	GE2_RD0/CP_LOS6	I	NVDD
F23	GE2_RD1	I	NVDD
F19	GE2_RD2/CP_LOS1	I	NVDD
E20	GE2_RD3/CP_LOS2	I	NVDD
F22	GE2_RX_CLK	I	NVDD
F20	GE2_RX_CTL	I	NVDD
C24	GE2_TD0	O	NVDD
C23	GE2_TD1	O	NVDD

**Table 2. Signal List by Primary Signal Name (continued)**

Ball Number	Signal Name <sup>1,2</sup>	Pin Type <sup>3</sup>	Power Rail Name
C20	GE2_TD2/CP_LOS3	I/O	NVDD
D22	GE2_TD3/CP_LOS5	I/O	NVDD
B20	GE2_TX_CLK	I	NVDD
C22	GE2_TX_CTL	O	NVDD
E26	GPIO0/ $\overline{\text{IRQ0}}$ /RC0/CP_SYNC1	I/O	NVDD
E28	GPIO1/ $\overline{\text{IRQ1}}$ /RC1/CP_SYNC2	I/O	NVDD
D28	GPIO10/ $\overline{\text{IRQ10}}$ /RC10	I/O	NVDD
G28	GPIO11/ $\overline{\text{IRQ11}}$ /RC11	I/O	NVDD
H28	GPIO12/ $\overline{\text{IRQ12}}$ /RC12	I/O	NVDD
D20	GPIO13/ $\overline{\text{IRQ13}}$ /RC13	I/O	NVDD
H26	GPIO14/DRQ0/ $\overline{\text{IRQ14}}$ /RC14	I/O	NVDD
C19	GPIO15/DDN0/ $\overline{\text{IRQ15}}$ /RC15	I/O	NVDD
D26	GPIO16/TMR5/RC16	I/O	NVDD
E27	GPIO17/SPI_SCK/CP_LOS3	I/O	NVDD
B28	GPIO18/SPI_MOSI/CP_LOS4	I/O	NVDD
G26	GPIO19/SPI_MISO/CP_LOS5	I/O	NVDD
K28	GPIO2/ $\overline{\text{IRQ2}}$ /RC2/CP_SYNC3	I/O	NVDD
C26	GPIO20/ $\overline{\text{SPI\_SL}}$ /CP_LOS6	I/O	NVDD
C28	GPIO21/TMR6	I/O	NVDD
F26	GPIO22	I/O	NVDD
F27	GPIO23/TMR0/BOOT_SPI_SL	I/O	NVDD
J22	GPIO24/TMR1/RCW_SRC2	I/O	NVDD
B24	GPIO25/TMR2/RCW_SRC1	I/O	NVDD
F24	GPIO26/TMR3	I/O	NVDD
E24	GPIO27/TMR4/RCW_SRC0	I/O	NVDD
G19	GPIO28/UART_RXD/CP_LOS1	I/O	NVDD
A20	GPIO29/UART_TXD/CP_LOS2	I/O	NVDD
J28	GPIO3/DRQ1/ $\overline{\text{IRQ3}}$ /RC3	I/O	NVDD
C25	GPIO30/I2C_SCL	I/O	NVDD
A21	GPIO31/I2C_SDA	I/O	NVDD
K22	GPIO4/DDN1/ $\overline{\text{IRQ4}}$ /RC4	I/O	NVDD
D24	GPIO5/ $\overline{\text{IRQ5}}$ /RC5/CP_SYNC4	I/O	NVDD
F25	GPIO6/ $\overline{\text{IRQ6}}$ /RC6/CP_SYNC5	I/O	NVDD
K26	GPIO7/ $\overline{\text{IRQ7}}$ /RC7/CP_SYNC6	I/O	NVDD

Table 2. Signal List by Primary Signal Name (continued)

Ball Number	Signal Name <sup>1,2</sup>	Pin Type <sup>3</sup>	Power Rail Name
F28	GPIO8/IRQ8/RC8	I/O	NVDD
J23	GPIO9/IRQ9/RC9	I/O	NVDD
A4	GVDD	Power	N/A
A7	GVDD	Power	N/A
AA4	GVDD	Power	N/A
AA9	GVDD	Power	N/A
AC11	GVDD	Power	N/A
AC2	GVDD	Power	N/A
AC5	GVDD	Power	N/A
AC8	GVDD	Power	N/A
AE10	GVDD	Power	N/A
AE4	GVDD	Power	N/A
AE7	GVDD	Power	N/A
AG11	GVDD	Power	N/A
AG2	GVDD	Power	N/A
AG5	GVDD	Power	N/A
AG8	GVDD	Power	N/A
C2	GVDD	Power	N/A
C5	GVDD	Power	N/A
E4	GVDD	Power	N/A
E7	GVDD	Power	N/A
G2	GVDD	Power	N/A
G5	GVDD	Power	N/A
J4	GVDD	Power	N/A
L2	GVDD	Power	N/A
L5	GVDD	Power	N/A
N4	GVDD	Power	N/A
R2	GVDD	Power	N/A
R5	GVDD	Power	N/A
R7	GVDD	Power	N/A
T8	GVDD	Power	N/A
U4	GVDD	Power	N/A
U7	GVDD	Power	N/A
V8	GVDD	Power	N/A

**Table 2. Signal List by Primary Signal Name (continued)**

Ball Number	Signal Name <sup>1,2</sup>	Pin Type <sup>3</sup>	Power Rail Name
W5	GVDD	Power	N/A
W7	GVDD	Power	N/A
Y8	GVDD	Power	N/A
E16	$\overline{\text{HRESET}}$	I/O	QVDD
D17	$\overline{\text{HRESET\_IN}}$	I	QVDD
E15	$\overline{\text{INT\_OUT/CP\_TX\_INT}}$	O	QVDD
AA11	M3VDD	Power	N/A
AA13	M3VDD	Power	N/A
AB12	M3VDD	Power	N/A
AB14	M3VDD	Power	N/A
AC13	M3VDD	Power	N/A
W11	M3VDD	Power	N/A
W13	M3VDD	Power	N/A
W15	M3VDD	Power	N/A
Y12	M3VDD	Power	N/A
Y14	M3VDD	Power	N/A
R3	MA0	O	GVDD
T4	MA1	O	GVDD
P2	MA10	O	GVDD
Y1	MA11	O	GVDD
Y3	MA12	O	GVDD
M3	MA13	O	GVDD
AA3	MA14	O	GVDD
AA6	MA15	O	GVDD
V4	MA2	O	GVDD
T5	MA3	O	GVDD
P4	MA4	O	GVDD
W3	MA5	O	GVDD
V5	MA6	O	GVDD
Y4	MA7	O	GVDD
V3	MA8	O	GVDD
Y2	MA9	O	GVDD
AB6	MAPAR_IN	I	GVDD
T6	MAPAR_OUT	O	GVDD



Table 2. Signal List by Primary Signal Name (continued)

Ball Number	Signal Name <sup>1,2</sup>	Pin Type <sup>3</sup>	Power Rail Name
U1	MAVDD	Power	N/A
R6	MBA0	O	GVDD
U6	MBA1	O	GVDD
AB7	MBA2	O	GVDD
K1	$\overline{\text{MCAS}}$	O	GVDD
M1	$\overline{\text{MCK0}}$	O	GVDD
M2	MCK0	O	GVDD
T3	$\overline{\text{MCK1}}$	O	GVDD
U3	MCK1	O	GVDD
P1	$\overline{\text{MCK2}}$	O	GVDD
R1	MCK2	O	GVDD
AA7	MCKE0	O	GVDD
V6	MCKE1	O	GVDD
A16	MCLKIN (optional)	I	QVDD
K2	$\overline{\text{MCS0}}$	O	GVDD
K3	$\overline{\text{MCS1}}$	O	GVDD
AD7	MDM0	O	GVDD
AH12	MDM1	O	GVDD
AH4	MDM2	O	GVDD
AH7	MDM3	O	GVDD
L6	MDM4	O	GVDD
G3	MDM5	O	GVDD
F7	MDM6	O	GVDD
C6	MDM7	O	GVDD
AB2	MDM8	O	GVDD
AB10	MDQ0	I/O	GVDD
AB9	MDQ1	I/O	GVDD
AF12	MDQ10	I/O	GVDD
AF10	MDQ11	I/O	GVDD
AG12	MDQ12	I/O	GVDD
AG9	MDQ13	I/O	GVDD
AF9	MDQ14	I/O	GVDD
AH11	MDQ15	I/O	GVDD
AF4	MDQ16	I/O	GVDD

**Table 2. Signal List by Primary Signal Name (continued)**

Ball Number	Signal Name <sup>1,2</sup>	Pin Type <sup>3</sup>	Power Rail Name
AF2	MDQ17	I/O	GVDD
AE3	MDQ18	I/O	GVDD
AH2	MDQ19	I/O	GVDD
AB8	MDQ2	I/O	GVDD
AH1	MDQ20	I/O	GVDD
AF3	MDQ21	I/O	GVDD
AG3	MDQ22	I/O	GVDD
AH3	MDQ23	I/O	GVDD
AD6	MDQ24	I/O	GVDD
AC6	MDQ25	I/O	GVDD
AG6	MDQ26	I/O	GVDD
AF6	MDQ27	I/O	GVDD
AF7	MDQ28	I/O	GVDD
AE6	MDQ29	I/O	GVDD
AC9	MDQ3	I/O	GVDD
AF5	MDQ30	I/O	GVDD
AH8	MDQ31	I/O	GVDD
K5	MDQ32	I/O	GVDD
J5	MDQ33	I/O	GVDD
K6	MDQ34	I/O	GVDD
J3	MDQ35	I/O	GVDD
J6	MDQ36	I/O	GVDD
J1	MDQ37	I/O	GVDD
H1	MDQ38	I/O	GVDD
K4	MDQ39	I/O	GVDD
AD10	MDQ4	I/O	GVDD
F1	MDQ40	I/O	GVDD
F2	MDQ41	I/O	GVDD
H6	MDQ42	I/O	GVDD
F5	MDQ43	I/O	GVDD
H4	MDQ44	I/O	GVDD
H5	MDQ45	I/O	GVDD
G6	MDQ46	I/O	GVDD
F6	MDQ47	I/O	GVDD

Table 2. Signal List by Primary Signal Name (continued)

Ball Number	Signal Name <sup>1,2</sup>	Pin Type <sup>3</sup>	Power Rail Name
D2	MDQ48	I/O	GVDD
D1	MDQ49	I/O	GVDD
AE9	MDQ5	I/O	GVDD
D5	MDQ50	I/O	GVDD
D6	MDQ51	I/O	GVDD
D7	MDQ52	I/O	GVDD
E1	MDQ53	I/O	GVDD
E6	MDQ54	I/O	GVDD
E3	MDQ55	I/O	GVDD
B7	MDQ56	I/O	GVDD
A3	MDQ57	I/O	GVDD
B6	MDQ58	I/O	GVDD
B2	MDQ59	I/O	GVDD
AD11	MDQ6	I/O	GVDD
B1	MDQ60	I/O	GVDD
C3	MDQ61	I/O	GVDD
B5	MDQ62	I/O	GVDD
A6	MDQ63	I/O	GVDD
AF8	MDQ7	I/O	GVDD
AF11	MDQ8	I/O	GVDD
AE12	MDQ9	I/O	GVDD
AD8	$\overline{\text{MDQS0}}$	I/O	GVDD
AD9	MDQS0	I/O	GVDD
AH10	MDQS1	I/O	GVDD
AH9	$\overline{\text{MDQS1}}$	I/O	GVDD
AE1	MDQS2	I/O	GVDD
AF1	$\overline{\text{MDQS2}}$	I/O	GVDD
AH5	$\overline{\text{MDQS3}}$	I/O	GVDD
AH6	MDQS3	I/O	GVDD
H2	$\overline{\text{MDQS4}}$	I/O	GVDD
H3	MDQS4	I/O	GVDD
F3	$\overline{\text{MDQS5}}$	I/O	GVDD
F4	MDQS5	I/O	GVDD
D3	$\overline{\text{MDQS6}}$	I/O	GVDD

Table 2. Signal List by Primary Signal Name (continued)

Ball Number	Signal Name <sup>1,2</sup>	Pin Type <sup>3</sup>	Power Rail Name
D4	MDQS6	I/O	GVDD
B3	$\overline{\text{MDQS7}}$	I/O	GVDD
B4	MDQS7	I/O	GVDD
AA1	MDQS8	I/O	GVDD
AB1	$\overline{\text{MDQS8}}$	I/O	GVDD
AD3	MECC0	I/O	GVDD
AB4	MECC1	I/O	GVDD
AB3	MECC2	I/O	GVDD
AD5	MECC3	I/O	GVDD
AC3	MECC4	I/O	GVDD
AD4	MECC5	I/O	GVDD
AD2	MECC6	I/O	GVDD
AD1	MECC7	I/O	GVDD
Y6	MMDIC0	I/O	GVDD
W6	MMDIC1	I/O	GVDD
P6	MODT0	O	GVDD
N6	MODT1	O	GVDD
N1	$\overline{\text{MRAS}}$	O	GVDD
V1	MVREF	Power	N/A
M4	$\overline{\text{MWE}}$	O	GVDD
A10	NC	Non-user	N/A
A11	NC	Non-user	N/A
A12	NC	Non-user	N/A
A8	NC	Non-user	N/A
A9	NC	Non-user	N/A
AA20	NC	NC	N/A
AA22	NC	NC	N/A
AA23	NC	NC	N/A
AA24	NC	NC	N/A
AB19	NC	NC	N/A
AB20	NC	Non-user	N/A
AB21	NC	NC	N/A
AB22	NC	NC	N/A
AB23	NC	NC	N/A

**Table 2. Signal List by Primary Signal Name (continued)**

Ball Number	Signal Name <sup>1,2</sup>	Pin Type <sup>3</sup>	Power Rail Name
AB24	NC	NC	N/A
AB5	NC	Non-user	N/A
AC17	NC	NC	N/A
AC18	NC	NC	N/A
AC19	NC	NC	N/A
AC20	NC	Non-user	N/A
AC21	NC	NC	N/A
AC22	NC	NC	N/A
AC23	NC	NC	N/A
AC24	NC	NC	N/A
AD17	NC	NC	N/A
AD19	NC	NC	N/A
AD20	NC	NC	N/A
AD21	NC	NC	N/A
AD22	NC	NC	N/A
AD23	NC	NC	N/A
AD24	NC	NC	N/A
AE17	NC	NC	N/A
AE19	NC	NC	N/A
AE24	NC	NC	N/A
AF17	NC	NC	N/A
AF18	NC	NC	N/A
AF19	NC	NC	N/A
AF24	NC	NC	N/A
AG17	NC	NC	N/A
AH17	NC	NC	N/A
B10	NC	Non-user	N/A
B12	NC	Non-user	N/A
B8	NC	Non-user	N/A
C10	NC	Non-user	N/A
C11	NC	Non-user	N/A
C12	NC	Non-user	N/A
C13	NC	Non-user	N/A
C15	NC	Non-user	N/A

**Table 2. Signal List by Primary Signal Name (continued)**

Ball Number	Signal Name <sup>1,2</sup>	Pin Type <sup>3</sup>	Power Rail Name
C8	NC	Non-user	N/A
C9	NC	Non-user	N/A
D10	NC	Non-user	N/A
D12	NC	Non-user	N/A
D14	NC	Non-user	N/A
D8	NC	Non-user	N/A
E10	NC	Non-user	N/A
E11	NC	Non-user	N/A
E12	NC	Non-user	N/A
E13	NC	Non-user	N/A
E14	NC	Non-user	N/A
E9	NC	Non-user	N/A
F11	NC	Non-user	N/A
F12	NC	Non-user	N/A
F14	NC	Non-user	N/A
G11	NC	Non-user	N/A
G12	NC	Non-user	N/A
G13	NC	Non-user	N/A
G14	NC	Non-user	N/A
H13	NC	Non-user	N/A
L22	NC	NC	N/A
L23	NC	NC	N/A
L3	NC	Non-user	N/A
M21	NC	NC	N/A
M22	NC	NC	N/A
M5	NC	Non-user	N/A
M6	NC	Non-user	N/A
N21	NC	NC	N/A
N22	NC	NC	N/A
N3	NC	Non-user	N/A
P21	NC	NC	N/A
P23	NC	NC	N/A
P24	NC	NC	N/A
P3	NC	Non-user	N/A

Table 2. Signal List by Primary Signal Name (continued)

Ball Number	Signal Name <sup>1,2</sup>	Pin Type <sup>3</sup>	Power Rail Name
P5	NC	Non-user	N/A
R21	NC	NC	N/A
R22	NC	NC	N/A
R23	NC	NC	N/A
R24	NC	NC	N/A
T21	NC	NC	N/A
T22	NC	Non-user	N/A
T23	NC	Non-user	N/A
T24	NC	NC	N/A
U21	NC	NC	N/A
U22	NC	NC	N/A
U23	NC	NC	N/A
U24	NC	NC	N/A
V21	NC	NC	N/A
V22	NC	NC	N/A
V23	NC	NC	N/A
V24	NC	NC	N/A
V25	NC	NC	N/A
V26	NC	NC	N/A
W21	NC	NC	N/A
W22	NC	NC	N/A
W23	NC	NC	N/A
W26	NC	NC	N/A
Y21	NC	NC	N/A
Y22	NC	NC	N/A
Y23	NC	NC	N/A
Y24	NC	NC	N/A
Y25	NC	NC	N/A
Y26	NC	NC	N/A
Y5	NC	Non-user	N/A
D15	$\overline{\text{NMI}}$	I	QVDD
F15	NMI_OUT/CP_RX_INT	O	QVDD
D21	NVDD	Power	N/A
D25	NVDD	Power	N/A

Table 2. Signal List by Primary Signal Name (continued)

Ball Number	Signal Name <sup>1,2</sup>	Pin Type <sup>3</sup>	Power Rail Name
E19	NVDD	Power	N/A
E23	NVDD	Power	N/A
G25	NVDD	Power	N/A
H20	NVDD	Power	N/A
H23	NVDD	Power	N/A
H27	NVDD	Power	N/A
J21	NVDD	Power	N/A
K25	NVDD	Power	N/A
L21	NVDD	Power	N/A
AH14	PLL0_AVDD	Power	N/A
AH15	PLL1_AVDD	Power	N/A
AH16	PLL2_AVDD	Power	N/A
C17	$\overline{\text{PORESET}}$	I	QVDD
G15	QVDD	Power	N/A
H14	QVDD	Power	N/A
J27	RC21	I	NVDD
J24	$\overline{\text{RCW\_LSEL0/RC17}}$	I/O	NVDD
K24	$\overline{\text{RCW\_LSEL1/RC18}}$	I/O	NVDD
J26	$\overline{\text{RCW\_LSEL2/RC19}}$	I/O	NVDD
J25	$\overline{\text{RCW\_LSEL3/RC20}}$	I/O	NVDD
M27	SD_A_RX	I	SXCVDD
M28	SD_A_RX	I	SXCVDD
M23	SD_A_TX	O	SXPVDD
M24	$\overline{\text{SD\_A\_TX}}$	O	SXPVDD
P27	$\overline{\text{SD\_B\_RX}}$	I	SXCVDD
P28	SD_B_RX	I	SXCVDD
N25	SD_B_TX	O	SXPVDD
N26	$\overline{\text{SD\_B\_TX}}$	O	SXPVDD
T27	$\overline{\text{SD\_C\_RX}}$	I	SXCVDD
T28	SD_C_RX	I	SXCVDD
R25	SD_C_TX	O	SXPVDD
R26	$\overline{\text{SD\_C\_TX}}$	O	SXPVDD
V27	$\overline{\text{SD\_D\_RX}}$	I	SXCVDD
V28	SD_D_RX	I	SXCVDD



Table 2. Signal List by Primary Signal Name (continued)

Ball Number	Signal Name <sup>1,2</sup>	Pin Type <sup>3</sup>	Power Rail Name
U25	SD_D_TX	O	SXPVDD
U26	$\overline{\text{SD\_D\_TX}}$	O	SXPVDD
AB27	$\overline{\text{SD\_E\_RX}}$	I	SXCVDD
AB28	SD_E_RX	I	SXCVDD
AA25	SD_E_TX	O	SXPVDD
AA26	$\overline{\text{SD\_E\_TX}}$	O	SXPVDD
AD27	$\overline{\text{SD\_F\_RX}}$	I	SXCVDD
AD28	SD_F_RX	I	SXCVDD
AC25	SD_F_TX	O	SXPVDD
AC26	$\overline{\text{SD\_F\_TX}}$	O	SXPVDD
AF27	$\overline{\text{SD\_G\_RX}}$	I	SXCVDD
AF28	SD_G_RX	I	SXCVDD
AE25	SD_G_TX	O	SXPVDD
AE26	$\overline{\text{SD\_G\_TX}}$	O	SXPVDD
AH27	$\overline{\text{SD\_H\_RX}}$	I	SXCVDD
AH28	SD_H_RX	I	SXCVDD
AG25	SD_H_TX	O	SXPVDD
AG26	$\overline{\text{SD\_H\_TX}}$	O	SXPVDD
AG23	$\overline{\text{SD\_I\_RX}}$	I	SXCVDD
AH23	SD_I_RX	I	SXCVDD
AE22	SD_I_TX	O	SXPVDD
AF22	$\overline{\text{SD\_I\_TX}}$	O	SXPVDD
P22	SD_IMP_CAL_RX	I	SXCVDD
AA21	SD_IMP_CAL_TX	I	SXPVDD
AG21	$\overline{\text{SD\_J\_RX}}$	I	SXCVDD
AH21	SD_J_RX	I	SXCVDD
AE20	SD_J_TX	O	SXPVDD
AF20	$\overline{\text{SD\_J\_TX}}$	O	SXPVDD
W25	SD_PLL1_AGND	Ground	N/A
W24	SD_PLL1_AVDD	Power	N/A
AE18	SD_PLL2_AGND	Ground	N/A
AD18	SD_PLL2_AVDD	Power	N/A
Y27	SD_REF_CLK1	I	SXCVDD
Y28	$\overline{\text{SD\_REF\_CLK1}}$	I	SXCVDD

**Table 2. Signal List by Primary Signal Name (continued)**

Ball Number	Signal Name <sup>1,2</sup>	Pin Type <sup>3</sup>	Power Rail Name
AG19	SD_REF_CLK2	I	SXCVDD
AH19	SD_REF_CLK2	I	SXCVDD
G16	STOP_BS	I	QVDD
AA28	SXCVDD	Power	N/A
AC28	SXCVDD	Power	N/A
AE28	SXCVDD	Power	N/A
AG28	SXCVDD	Power	N/A
AH18	SXCVDD	Power	N/A
AH20	SXCVDD	Power	N/A
AH22	SXCVDD	Power	N/A
AH24	SXCVDD	Power	N/A
L28	SXCVDD	Power	N/A
N28	SXCVDD	Power	N/A
R28	SXCVDD	Power	N/A
U28	SXCVDD	Power	N/A
W28	SXCVDD	Power	N/A
AA27	SXCVSS	Ground	N/A
AC27	SXCVSS	Ground	N/A
AE27	SXCVSS	Ground	N/A
AG18	SXCVSS	Ground	N/A
AG20	SXCVSS	Ground	N/A
AG22	SXCVSS	Ground	N/A
AG24	SXCVSS	Ground	N/A
AG27	SXCVSS	Ground	N/A
L27	SXCVSS	Ground	N/A
N27	SXCVSS	Ground	N/A
R27	SXCVSS	Ground	N/A
U27	SXCVSS	Ground	N/A
W27	SXCVSS	Ground	N/A
AB25	SXPVDD	Power	N/A
AD25	SXPVDD	Power	N/A
AE21	SXPVDD	Power	N/A
AE23	SXPVDD	Power	N/A
AF25	SXPVDD	Power	N/A

Table 2. Signal List by Primary Signal Name (continued)

Ball Number	Signal Name <sup>1,2</sup>	Pin Type <sup>3</sup>	Power Rail Name
AH25	SXPVDD	Power	N/A
M25	SXPVDD	Power	N/A
N23	SXPVDD	Power	N/A
P25	SXPVDD	Power	N/A
T25	SXPVDD	Power	N/A
AB26	SXPVSS	Ground	N/A
AD26	SXPVSS	Ground	N/A
AF21	SXPVSS	Ground	N/A
AF23	SXPVSS	Ground	N/A
AF26	SXPVSS	Ground	N/A
AH26	SXPVSS	Ground	N/A
M26	SXPVSS	Ground	N/A
N24	SXPVSS	Ground	N/A
P26	SXPVSS	Ground	N/A
T26	SXPVSS	Ground	N/A
E17	TCK	I	QVDD
F17	TDI	I	QVDD
B14	TDO	O	QVDD
B15	TMS	I	QVDD
G17	$\overline{\text{TRST}}$	I	QVDD
F10	VDD	Power	N/A
F8	VDD	Power	N/A
G7	VDD	Power	N/A
G9	VDD	Power	N/A
H10	VDD	Power	N/A
H16	VDD	Power	N/A
H18	VDD	Power	N/A
H8	VDD	Power	N/A
J11	VDD	Power	N/A
J13	VDD	Power	N/A
J15	VDD	Power	N/A
J17	VDD	Power	N/A
J19	VDD	Power	N/A
J7	VDD	Power	N/A

**Table 2. Signal List by Primary Signal Name (continued)**

Ball Number	Signal Name <sup>1,2</sup>	Pin Type <sup>3</sup>	Power Rail Name
J9	VDD	Power	N/A
K10	VDD	Power	N/A
K12	VDD	Power	N/A
K14	VDD	Power	N/A
K16	VDD	Power	N/A
K18	VDD	Power	N/A
K20	VDD	Power	N/A
K8	VDD	Power	N/A
L11	VDD	Power	N/A
L13	VDD	Power	N/A
L15	VDD	Power	N/A
L17	VDD	Power	N/A
L19	VDD	Power	N/A
L7	VDD	Power	N/A
L9	VDD	Power	N/A
M10	VDD	Power	N/A
M12	VDD	Power	N/A
M14	VDD	Power	N/A
M16	VDD	Power	N/A
M18	VDD	Power	N/A
M20	VDD	Power	N/A
M8	VDD	Power	N/A
N13	VDD	Power	N/A
N15	VDD	Power	N/A
N17	VDD	Power	N/A
N19	VDD	Power	N/A
P12	VDD	Power	N/A
P14	VDD	Power	N/A
P16	VDD	Power	N/A
P18	VDD	Power	N/A
P20	VDD	Power	N/A
R13	VDD	Power	N/A
R15	VDD	Power	N/A
R17	VDD	Power	N/A

**Table 2. Signal List by Primary Signal Name (continued)**

Ball Number	Signal Name <sup>1,2</sup>	Pin Type <sup>3</sup>	Power Rail Name
R19	VDD	Power	N/A
R9	VDD	Power	N/A
T10	VDD	Power	N/A
T12	VDD	Power	N/A
T14	VDD	Power	N/A
T16	VDD	Power	N/A
T18	VDD	Power	N/A
T20	VDD	Power	N/A
U11	VDD	Power	N/A
U13	VDD	Power	N/A
U15	VDD	Power	N/A
U17	VDD	Power	N/A
U19	VDD	Power	N/A
U9	VDD	Power	N/A
V10	VDD	Power	N/A
V12	VDD	Power	N/A
V14	VDD	Power	N/A
V16	VDD	Power	N/A
V18	VDD	Power	N/A
V20	VDD	Power	N/A
W19	VDD	Power	N/A
W9	VDD	Power	N/A
Y10	VDD	Power	N/A
Y20	VDD	Power	N/A
A15	VSS	Ground	N/A
A17	VSS	Ground	N/A
A19	VSS	Ground	N/A
A2	VSS	Ground	N/A
A5	VSS	Ground	N/A
AA10	VSS	Ground	N/A
AA12	VSS	Ground	N/A
AA14	VSS	Ground	N/A
AA16	VSS	Ground	N/A
AA18	VSS	Ground	N/A

**Table 2. Signal List by Primary Signal Name (continued)**

Ball Number	Signal Name <sup>1,2</sup>	Pin Type <sup>3</sup>	Power Rail Name
AA2	VSS	Ground	N/A
AA5	VSS	Ground	N/A
AA8	VSS	Ground	N/A
AB11	VSS	Ground	N/A
AB13	VSS	Ground	N/A
AB15	VSS	Ground	N/A
AB17	VSS	Ground	N/A
AC1	VSS	Ground	N/A
AC10	VSS	Ground	N/A
AC12	VSS	Ground	N/A
AC14	VSS	Ground	N/A
AC16	VSS	Ground	N/A
AC4	VSS	Ground	N/A
AC7	VSS	Ground	N/A
AD12	VSS	Non-user	N/A
AD13	VSS	Non-user	N/A
AD14	VSS	Non-user	N/A
AD15	VSS	Ground	N/A
AD16	VSS	Ground	N/A
AE11	VSS	Ground	N/A
AE13	VSS	Non-user	N/A
AE14	VSS	Ground	N/A
AE15	VSS	Ground	N/A
AE16	VSS	Ground	N/A
AE2	VSS	Ground	N/A
AE5	VSS	Ground	N/A
AE8	VSS	Ground	N/A
AF13	VSS	Non-user	N/A
AF14	VSS	Ground	N/A
AF15	VSS	Ground	N/A
AF16	VSS	Ground	N/A
AG1	VSS	Ground	N/A
AG10	VSS	Ground	N/A
AG13	VSS	Ground	N/A

**Table 2. Signal List by Primary Signal Name (continued)**

Ball Number	Signal Name <sup>1,2</sup>	Pin Type <sup>3</sup>	Power Rail Name
AG14	VSS	Ground	N/A
AG15	VSS	Ground	N/A
AG16	VSS	Ground	N/A
AG4	VSS	Ground	N/A
AG7	VSS	Ground	N/A
AH13	VSS	Ground	N/A
B11	VSS	Ground	N/A
B13	VSS	Ground	N/A
B16	VSS	Ground	N/A
B17	VSS	Ground	N/A
B18	VSS	Ground	N/A
B19	VSS	Ground	N/A
B21	VSS	Ground	N/A
B22	VSS	Non-user	N/A
B23	VSS	Ground	N/A
B25	VSS	Ground	N/A
B27	VSS	Ground	N/A
B9	VSS	Ground	N/A
C1	VSS	Ground	N/A
C18	VSS	Ground	N/A
C4	VSS	Ground	N/A
C7	VSS	Ground	N/A
D11	VSS	Ground	N/A
D13	VSS	Ground	N/A
D16	VSS	Ground	N/A
D18	VSS	Ground	N/A
D19	VSS	Non-user	N/A
D23	VSS	Ground	N/A
D9	VSS	Ground	N/A
E18	VSS	Ground	N/A
E2	VSS	Ground	N/A
E21	VSS	Ground	N/A
E22	VSS	Non-user	N/A
E25	VSS	Ground	N/A

**Table 2. Signal List by Primary Signal Name (continued)**

Ball Number	Signal Name <sup>1,2</sup>	Pin Type <sup>3</sup>	Power Rail Name
E5	VSS	Ground	N/A
E8	VSS	Ground	N/A
F13	VSS	Ground	N/A
F16	VSS	Ground	N/A
F18	VSS	Ground	N/A
F9	VSS	Ground	N/A
G1	VSS	Ground	N/A
G10	VSS	Ground	N/A
G18	VSS	Ground	N/A
G23	VSS	Ground	N/A
G27	VSS	Ground	N/A
G4	VSS	Ground	N/A
G8	VSS	Ground	N/A
H11	VSS	Ground	N/A
H12	VSS	Non-user	N/A
H15	VSS	Ground	N/A
H17	VSS	Ground	N/A
H19	VSS	Ground	N/A
H21	VSS	Ground	N/A
H25	VSS	Ground	N/A
H7	VSS	Ground	N/A
H9	VSS	Ground	N/A
J10	VSS	Ground	N/A
J12	VSS	Ground	N/A
J14	VSS	Ground	N/A
J16	VSS	Ground	N/A
J18	VSS	Ground	N/A
J2	VSS	Ground	N/A
J20	VSS	Ground	N/A
J8	VSS	Ground	N/A
K11	VSS	Ground	N/A
K13	VSS	Ground	N/A
K15	VSS	Ground	N/A
K17	VSS	Ground	N/A



**Table 2. Signal List by Primary Signal Name (continued)**

Ball Number	Signal Name <sup>1,2</sup>	Pin Type <sup>3</sup>	Power Rail Name
K19	VSS	Ground	N/A
K21	VSS	Ground	N/A
K23	VSS	Ground	N/A
K27	VSS	Ground	N/A
K7	VSS	Ground	N/A
K9	VSS	Ground	N/A
L1	VSS	Ground	N/A
L10	VSS	Ground	N/A
L12	VSS	Ground	N/A
L14	VSS	Ground	N/A
L16	VSS	Ground	N/A
L18	VSS	Ground	N/A
L20	VSS	Ground	N/A
L24	VSS	Non-user	N/A
L25	VSS	Non-user	N/A
L26	VSS	Non-user	N/A
L4	VSS	Ground	N/A
L8	VSS	Ground	N/A
M11	VSS	Ground	N/A
M13	VSS	Ground	N/A
M15	VSS	Ground	N/A
M17	VSS	Ground	N/A
M19	VSS	Ground	N/A
M7	VSS	Ground	N/A
M9	VSS	Ground	N/A
N10	VSS	Ground	N/A
N12	VSS	Ground	N/A
N14	VSS	Ground	N/A
N16	VSS	Ground	N/A
N18	VSS	Ground	N/A
N2	VSS	Ground	N/A
N20	VSS	Ground	N/A
N5	VSS	Ground	N/A
N8	VSS	Ground	N/A

**Table 2. Signal List by Primary Signal Name (continued)**

Ball Number	Signal Name <sup>1,2</sup>	Pin Type <sup>3</sup>	Power Rail Name
P11	VSS	Ground	N/A
P13	VSS	Ground	N/A
P15	VSS	Ground	N/A
P17	VSS	Ground	N/A
P19	VSS	Ground	N/A
P7	VSS	Ground	N/A
P9	VSS	Ground	N/A
R10	VSS	Ground	N/A
R12	VSS	Ground	N/A
R14	VSS	Ground	N/A
R16	VSS	Ground	N/A
R18	VSS	Ground	N/A
R20	VSS	Ground	N/A
R4	VSS	Ground	N/A
R8	VSS	Ground	N/A
T1	VSS	Ground	N/A
T11	VSS	Ground	N/A
T13	VSS	Ground	N/A
T15	VSS	Ground	N/A
T17	VSS	Ground	N/A
T19	VSS	Ground	N/A
T2	VSS	Ground	N/A
T7	VSS	Ground	N/A
T9	VSS	Ground	N/A
U10	VSS	Ground	N/A
U12	VSS	Ground	N/A
U14	VSS	Ground	N/A
U16	VSS	Ground	N/A
U18	VSS	Ground	N/A
U2	VSS	Ground	N/A
U20	VSS	Ground	N/A
U5	VSS	Ground	N/A
U8	VSS	Ground	N/A
V11	VSS	Ground	N/A

**Table 2. Signal List by Primary Signal Name (continued)**

Ball Number	Signal Name <sup>1,2</sup>	Pin Type <sup>3</sup>	Power Rail Name
V13	VSS	Ground	N/A
V15	VSS	Ground	N/A
V17	VSS	Ground	N/A
V19	VSS	Ground	N/A
V2	VSS	Ground	N/A
V7	VSS	Ground	N/A
V9	VSS	Ground	N/A
W1	VSS	Ground	N/A
W10	VSS	Ground	N/A
W12	VSS	Ground	N/A
W14	VSS	Ground	N/A
W16	VSS	Ground	N/A
W18	VSS	Ground	N/A
W2	VSS	Ground	N/A
W20	VSS	Ground	N/A
W4	VSS	Ground	N/A
W8	VSS	Ground	N/A
Y11	VSS	Ground	N/A
Y13	VSS	Ground	N/A
Y15	VSS	Ground	N/A
Y17	VSS	Ground	N/A
Y19	VSS	Ground	N/A
Y7	VSS	Ground	N/A
Y9	VSS	Ground	N/A
D27	VSS'	Ground	N/A

Signal function during power-on reset is determined by the RCW source type. Selection of RapidIO, SGMII, CPRI, and PCI Express functionality during normal operation is configured by the RCW bit values. Selection of the GPIO function and other functions is done by GPIO register setup. For signals with GPIO functionality, the open-drain and internal 20 K $\Omega$  pull-up resistor can be configured by GPIO register programming. For configuration details, see the *GPIO* chapter in the *MSC8157 Reference Manual*.

NC signals should be disconnected for compatibility with future revisions of the device. Non-user signals are reserved for manufacturing and test purposes only. The assigned signal name is used to indicate whether the signal must be unconnected (Reserved), pulled down (VSS or SXC VSS), or pulled up (VDD).

Pin types are: Ground = all VSS connections; Power = all VDD connections; I = Input; O = Output; I/O = Input/Output; NC = not connected; non-user = connect as specified under Signal Name.

Connect power inputs to the power supplies via external filters. See the *MSC8157 Design Checklist* (AN4110) for details.

### 3 Electrical Characteristics

This document contains detailed information on power considerations, DC/AC electrical characteristics, and AC timing specifications. For additional information, see the *MSC8157 Reference Manual*.

#### 3.1 Maximum Ratings

In calculating timing requirements, adding a maximum value of one specification to a minimum value of another specification does not yield a reasonable sum. A maximum specification is calculated using a worst case variation of process parameter values in one direction. The minimum specification is calculated using the worst case for the same parameters in the opposite direction. Therefore, a “maximum” value for a specification never occurs in the same device with a “minimum” value for another specification; adding a maximum to a minimum represents a condition that can never exist.

Table 3 describes the maximum electrical ratings for the MSC8157.

**Table 3. Absolute Maximum Ratings**

Rating	Power Rail Name	Symbol	Value	Unit
Core supply voltage • Cores 0–5	VDD	$V_{DD}$	-0.3 to 1.1	V
PLL supply voltage <sup>3</sup>	PLL0_AVDD	$V_{DDPLL0}$	-0.3 to 1.1	V
	PLL1_AVDD	$V_{DDPLL1}$	-0.3 to 1.1	V
	PLL2_AVDD	$V_{DDPLL2}$	-0.3 to 1.1	V
	MAVDD	$V_{DDPLLM}$	-0.3 to 1.1	V
	SD_PLL1_AVDD	$V_{DDPLL}$	-0.3 to 1.1	V
	SD_PLL2_AVDD	$V_{DDPLL}$	-0.3 to 1.1	V
CRPE supply voltage	CRPEVDD	$V_{DDCRPE}$	-0.3 to 1.1	V
CPRI supply voltage	CPRIVDD	$V_{DDCPRI}$	-0.3 to 1.1	V
M3 memory supply voltage	M3VDD	$V_{DDM3}$	-0.3 to 1.1	V
DDR memory supply voltage	GVDD	$V_{DDDDR}$	-0.3 to 1.65	V
DDR reference voltage	MVREF	$MV_{REF}$	-0.3 to $0.51 \times V_{DDDDR}$	V
Input DDR voltage		$V_{INDDR}$	-0.3 to $V_{DDDDR} + 0.3$	V
I/O voltage excluding DDR and RapidIO lines	NVDD, QVDD	$V_{DDIO}$	-0.3 to 2.625	V
Input I/O voltage		$V_{INIO}$	-0.3 to $V_{DDIO} + 0.3$	V
SerDes pad voltage	SXPVDD	$V_{DDSPX}$	-0.3 to 1.65	V
SerDes core voltage	SXCVDD	$V_{DDSCX}$	-0.3 to 1.21	V
SerDes PLL voltage <sup>3</sup>		$V_{DDRIOPLL}$	-0.3 to 1.21	V
Input SerDes I/O voltage		$V_{INRIO}$	-0.3 to $V_{DDSCX} + 0.3$	V
Operating temperature		$T_J$	-40 to 105	°C
Storage temperature range		$T_{STG}$	-55 to +150	°C

- Notes:**
1. Functional operating conditions are given in Table 4.
  2. Absolute maximum ratings are stress ratings only, and functional operation at the maximum is not guaranteed. Stress beyond the listed limits may affect device reliability or cause permanent damage.
  3. PLL supply voltage is specified at input of the filter and not at pin of the MSC8157 (see the MSC8157 Design Checklist (AN4110))

## 3.2 Recommended Operating Conditions

Table 4 lists recommended operating conditions. Proper device operation outside of these conditions is not guaranteed.

**Table 4. Recommended Operating Conditions**

Rating	Supply	Min	Nominal	Max	Unit
Core supply voltage <sup>1</sup>	VDD	0.97	1.0	1.05	V
PLL supply voltage <sup>1,3</sup>	PLL0_AVDD PLL1_AVDD PLL2_AVDD MAVDD SD_PLL1_AVDD SD_PLL2_AVDD	0.97	1.0	1.05	V
CRPE supply voltage <sup>1</sup>	CRPEVDD	0.97	1.0	1.05	V
CPRI supply voltage <sup>1</sup>	CPRIVDD	0.97	1.0	1.05	V
Switchable M3 memory supply voltage <sup>1</sup>	M3VDD	0.97	1.0	1.05	V
DDR memory supply voltage	GVDD	1.425	1.5	1.575	V
DDR reference voltage	MVREF	$0.49 \times GVDD$ (nom)	$0.5 \times GVDD$ (nom)	$0.51 \times GVDD$ (nom)	V
RGMII Ethernet and GPIO supply voltage <sup>2</sup>	NVDD	2.375	2.5	2.625	V
Input/output clocks, reset signal, and JTAG supply voltage <sup>2</sup>	QVDD	2.375	2.5	2.625	V
SerDes pad supply voltage	SXPVDD	1.425	1.5	1.575	V
SerDes core supply voltage <sup>1</sup>	SXCVDD	0.97	1.0	1.05	V
Operating temperature range:					
• Standard	$T_J$	0		105	°C
• Extended	$T_A$	-40		—	°C
	$T_J$	—		105	°C

- Notes:**
1. Designates supplies that use the same 1.0 V nominal voltage level.
  2. Designates supplies that use the same 2.5 V nominal voltage level.
  3. PLL supply voltage is specified at the input of the filter and not at the MSC8157 pin for the supply.

### 3.3 Thermal Characteristics

Table 5 describes thermal characteristics of the MSC8157 for the FC-PBGA packages.

**Table 5. Thermal Characteristics for the MSC8157**

Characteristic	Symbol	FC-PBGA 29 × 29 mm <sup>2</sup>		Unit
		Natural Convection	200 ft/min (1 m/s) airflow	
Junction-to-ambient <sup>1, 2</sup>	R <sub>θJA</sub>	18	12	°C/W
Junction-to-ambient, four-layer board <sup>1, 2</sup>	R <sub>θJA</sub>	13	9	°C/W
Junction-to-board (bottom) <sup>3</sup>	R <sub>θJB</sub>	4		°C/W
Junction-to-case <sup>4</sup>	R <sub>θJC</sub>	0.4		°C/W

- Notes:**
1. Junction temperature is a function of die size, on-chip power dissipation, package thermal resistance, mounting site (board) temperature, ambient temperature, air flow, power dissipation of other components on the board, and board thermal resistance.
  2. Junction-to-ambient thermal resistance determined per JEDEC JESD51-3 and JESDC51-6. Thermal test board meets JEDEC specification for the specified package.
  3. Junction-to-board thermal resistance determined per JEDEC JESD 51-8. Thermal test board meets JEDEC specification for the specified package.
  4. Junction-to-case at the top of the package determined using MIL-STD-883 Method 1012.1. The cold plate temperature is used for the case temperature. Reported value includes the thermal resistance of the interface layer

### 3.4 CLKIN/MCLKIN Requirements

Table 6 summarizes the required characteristics for the CLKIN/MCLKIN signal.

**Table 6. CLKIN/MCLKIN Requirements**

Parameter/Condition <sup>1</sup>	Symbol	Min	Typ	Max	Unit	Notes
CLKIN/MCLKIN duty cycle	—	40	—	60	%	2
CLKIN/MCLKIN slew rate	—	1	—	4	V/ns	3
CLKIN/MCLKIN peak period jitter	—	—	—	±150	ps	—
CLKIN/MCLKIN jitter phase noise at -56 dBc	—	—	—	500	KHz	4
AC input swing limits	ΔV <sub>AC</sub>	1.5	—	—	V	—
Input capacitance	C <sub>IN</sub>	—	—	15	pf	5

- Notes:**
1. For clock frequencies, see the *Clock* chapter in the *MSC8157 Reference Manual*.
  2. Measured at the rising edge and/or the falling edge at V<sub>DDIO</sub>/2.
  3. Slew rate as measured from ±20% to 80% of voltage swing at clock input.
  4. Phase noise is calculated as FFT of TIE jitter.
  5. The specified capacitance is not an external requirement. It represents the internal capacitance specification.

### 3.5 DC Electrical Characteristics

This section describes the DC electrical characteristics for the MSC8157.

### 3.5.1 DDR SDRAM Electrical Characteristics

This section describes the DC electrical specifications for the DDR SDRAM interface of the MSC8157. Table 7 provides the recommended operating conditions for the DDR SDRAM controller when interfacing to DDR3 SDRAM.

**Table 7. DDR3 SDRAM Interface DC Electrical Characteristics**

At recommended operating conditions (see Table 4) with GVDD = 1.5 V.

Parameter/Condition	Symbol	Min	Max	Unit	Notes
I/O reference voltage	$MV_{REF}$	$0.49 \times V_{DDDDR}$	$0.51 \times V_{DDDDR}$	V	2,3,4
Input high voltage	$V_{IH}$	$MV_{REF} + 0.100$	$V_{DDDDR}$	V	5
Input low voltage	$V_{IL}$	GND	$MV_{REF} - 0.100$	V	5
Output high current ( $V_{OUT} = 0.7125$ V)	$I_{OH}$	—	-25.9	mA	6, 7
Output low current ( $V_{OUT} = 0.7125$ V)	$I_{OL}$	25.9	—	mA	6, 7
I/O leakage current	$I_{OZ}$	-50	50	$\mu$ A	8

- Notes:**
- $V_{DDDDR}$  is expected to be within 50 mV of the DRAM  $V_{DD}$  at all times. The DRAM and memory controller can use the same or different sources.
  - $MV_{REF}$  is expected to be equal to  $0.5 \times V_{DDDDR}$  and to track  $V_{DDDDR}$  DC variations as measured at the receiver. Peak-to-peak noise on  $MV_{REF}$  may not exceed 1% of the  $V_{DDDDR}$  DC value (that is, 15 mV).
  - $V_{TT}$  is not applied directly to the device. It is the supply to which the far end signal termination is made and is expected to be equal to  $MV_{REF}$  with a minimum value of  $MV_{REF} - 0.04$  and a maximum value of  $MV_{REF} + 0.04$  V.  $V_{TT}$  should track variations in the DC-level of  $MV_{REF}$ .
  - The voltage regulator for  $MV_{REF}$  must meet the specifications stated in Table 9.
  - Input capacitance load for DQ, DQS, and  $\overline{DQS}$  signals are available in the IBIS models.
  - $I_{OH}$  and  $I_{OL}$  are measured at  $V_{DDDDR} = 1.425$  V.
  - Refer to the IBIS model for the complete output IV curve characteristics.
  - Output leakage is measured with all outputs are disabled,  $0 \text{ V} \leq V_{OUT} \leq V_{DDDDR}$ .

Table 8 provides the DDR controller interface capacitance for DDR3 memory.

**Table 8. DDR3 SDRAM Capacitance**

At recommended operating conditions (see Table 4) with  $V_{DDDDR} = 1.5$  V.

Parameter	Symbol	Min	Max	Unit
I/O capacitance: DQ, DQS, $\overline{DQS}$	$C_{IO}$	6	8	pF
Delta I/O capacitance: DQ, DQS, $\overline{DQS}$	$C_{DIO}$	—	0.5	pF

**Note:** Guaranteed by FAB process and micro-construction.

Table 9 lists the current draw characteristics for  $MV_{REF}$ .

**Table 9. Current Draw Characteristics for  $MV_{REF}$**

At recommended operating conditions (see Table 4).

Parameter / Condition	Symbol	Min	Max	Unit
Current draw for $MV_{REF}$	$I_{MVREFn}$	—	1250	$\mu$ A

### 3.5.2 High-Speed Serial Interface (HSSI) DC Electrical Characteristics

The MSC8157 features an HSSI that includes one 10-channel SerDes port (lanes A through J) used for high-speed serial interface applications (PCI Express, Serial RapidIO interfaces, CPRI, and SGMII). This section and its subsections describe the common portion of the SerDes DC, including the DC requirements for the SerDes reference clocks and the SerDes data lane

## Electrical Characteristics

transmitter (Tx) and receiver (Rx) reference circuits. The data lane circuit specifications are specific for each supported interface, and they have individual subsections by protocol. The selection of individual data channel functionality is done via the Reset Configuration Word High Register (RCWHR) SerDes Protocol selection fields (S1P and S2P). Specific AC electrical characteristics are defined in [Section 3.6.2, “HSSI AC Timing Specifications.”](#)

### 3.5.2.1 Signal Term Definitions

The SerDes interface uses differential signaling to transfer data across the serial link. This section defines terms used in the description and specification of differential signals. [Figure 2](#) shows how the signals are defined in addition to the waveform for either a transmitter output ( $SD_{[A-J]}_{TX}$  and  $\overline{SD}_{[A-J]}_{TX}$ ) or a receiver input ( $SD_{[A-J]}_{RX}$  and  $\overline{SD}_{[A-J]}_{RX}$ ). Each signal swings between X volts and Y volts where  $X > Y$ .

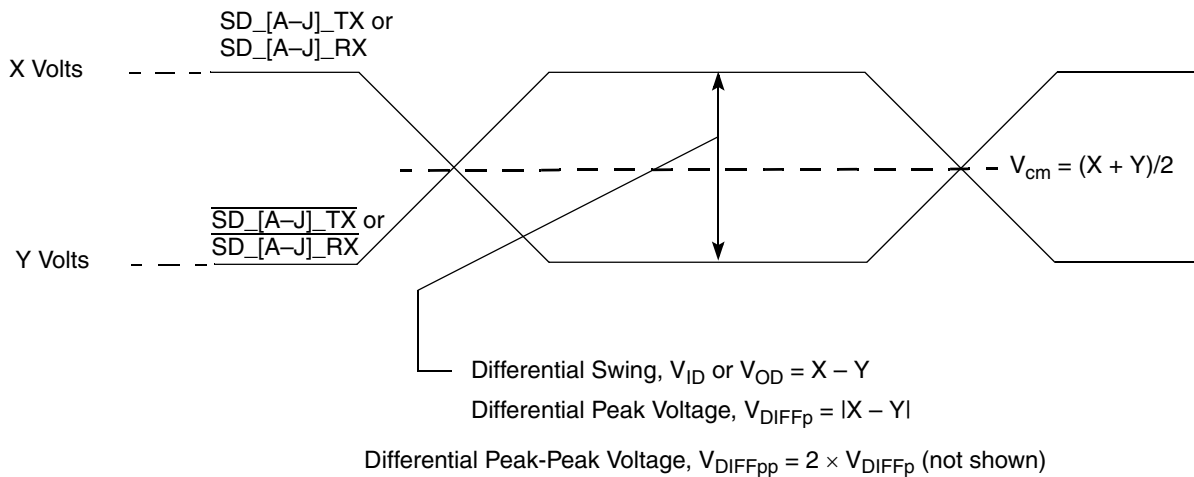

**Figure 2. Differential Voltage Definitions for Transmitter/Receiver**

Using this waveform, the definitions are listed in [Table 10](#). To simplify the illustration, the definitions assume that the SerDes transmitter and receiver operate in a fully symmetrical differential signaling environment.

**Table 10. Differential Signal Definitions**

Term	Definition
Single-Ended Swing	The transmitter output signals and the receiver input signals $SD_{[A-J]}_{TX}$ , $\overline{SD}_{[A-J]}_{TX}$ , $SD_{[A-J]}_{RX}$ and $\overline{SD}_{[A-J]}_{RX}$ each have a peak-to-peak swing of $X - Y$ volts. This is also referred to as each signal wire's single-ended swing.
Differential Output Voltage, $V_{OD}$ (or Differential Output Swing)	The differential output voltage (or swing) of the transmitter, $V_{OD}$ , is defined as the difference of the two complimentary output voltages: $V_{SD_{[A-J]}_{TX}} - V_{\overline{SD}_{[A-J]}_{TX}}$ . The $V_{OD}$ value can be either positive or negative.
Differential Input Voltage, $V_{ID}$ (or Differential Input Swing)	The differential input voltage (or swing) of the receiver, $V_{ID}$ , is defined as the difference of the two complimentary input voltages: $V_{SD_{[A-J]}_{RX}} - V_{\overline{SD}_{[A-J]}_{RX}}$ . The $V_{ID}$ value can be either positive or negative.



**Table 10. Differential Signal Definitions (continued)**

Term	Definition
Differential Peak Voltage, $V_{DIFFp}$	The peak value of the differential transmitter output signal or the differential receiver input signal is defined as the differential peak voltage, $V_{DIFFp} =  X - Y $ volts.
Differential Peak-to-Peak, $V_{DIFFp-p}$	Since the differential output signal of the transmitter and the differential input signal of the receiver each range from $A - B$ to $-(A - B)$ volts, the peak-to-peak value of the differential transmitter output signal or the differential receiver input signal is defined as differential peak-to-peak voltage, $V_{DIFFp-p} = 2 \times V_{DIFFp} = 2 \times  (A - B) $ volts, which is twice the differential swing in amplitude, or twice of the differential peak. For example, the output differential peak-peak voltage can also be calculated as $V_{TX-DIFFp-p} = 2 \times  V_{OD} $ .
Differential Waveform	The differential waveform is constructed by subtracting the inverting signal ( $\overline{SD_{[A-J]_{TX}}}$ , for example) from the non-inverting signal ( $SD_{[A-J]_{TX}}$ , for example) within a differential pair. There is only one signal trace curve in a differential waveform. The voltage represented in the differential waveform is not referenced to ground. Refer to <a href="#">Figure 2</a> as an example for differential waveform.
Common Mode Voltage, $V_{cm}$	The common mode voltage is equal to half of the sum of the voltages between each conductor of a balanced interchange circuit and ground. In this example, for SerDes output, $V_{cm\_out} = (V_{SD_{[A-J]_{TX}}} + V_{\overline{SD_{[A-J]_{TX}}}}) \div 2 = (A + B) \div 2$ , which is the arithmetic mean of the two complimentary output voltages within a differential pair. In a system, the common mode voltage may often differ from one component's output to the other's input. It may be different between the receiver input and driver output circuits within the same component. It is also referred to as the DC offset on some occasions.

To illustrate these definitions using real values, consider the example of a current mode logic (CML) transmitter that has a common mode voltage of 2.25 V and outputs, TD and  $\overline{TD}$ . If these outputs have a swing from 2.0 V to 2.5 V, the peak-to-peak voltage swing of each signal (TD or  $\overline{TD}$ ) is 500 mV p-p, which is referred to as the single-ended swing for each signal. Because the differential signaling environment is fully symmetrical in this example, the transmitter output differential swing ( $V_{OD}$ ) has the same amplitude as each signal single-ended swing. The differential output signal ranges between 500 mV and -500 mV. In other words,  $V_{OD}$  is 500 mV in one phase and -500 mV in the other phase. The peak differential voltage ( $V_{DIFFp}$ ) is 500 mV. The peak-to-peak differential voltage ( $V_{DIFFp-p}$ ) is 1000 mV p-p.

### 3.5.2.2 SerDes Reference Clock Receiver Characteristics

The SerDes reference clock inputs are applied to an internal PLL whose output creates the clock used by the corresponding SerDes lanes. The SerDes reference clock inputs are  $SD\_REF\_CLK1/SD\_REF\_CLK\overline{1}$  or  $SD\_REF\_CLK2/SD\_REF\_CLK\overline{2}$ . [Figure 3](#) shows a receiver reference diagram of the SerDes reference clocks.

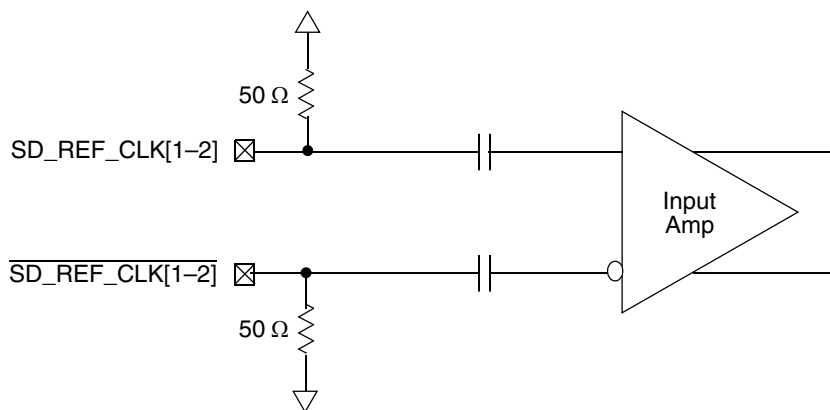
**Figure 3. Receiver of SerDes Reference Clocks**

## Electrical Characteristics

The characteristics of the clock signals are as follows:

- The supply voltage requirements for  $V_{DD\text{SXC}}$  are as specified in [Table 4](#).
- The SerDes reference clock receiver reference circuit structure is as follows:
  - The  $\overline{\text{SD\_REF\_CLK}}[1-2]$  and  $\overline{\text{SD\_REF\_CLK}}[1-2]$  are internally AC-coupled differential inputs as shown in [Figure 3](#). Each differential clock input ( $\overline{\text{SD\_REF\_CLK}}[1-2]$  or  $\overline{\text{SD\_REF\_CLK}}[1-2]$ ) has on-chip 50- $\Omega$  termination to  $\text{SXC}\overline{\text{VSS}}$  followed by on-chip AC-coupling.
  - The external reference clock driver must be able to drive this termination.
  - The SerDes reference clock input can be either differential or single-ended. Refer to the differential mode and single-ended mode descriptions below for detailed requirements.
- The maximum average current requirement also determines the common mode voltage range.
  - When the SerDes reference clock differential inputs are DC coupled externally with the clock driver chip, the maximum average current allowed for each input pin is 8 mA. In this case, the exact common mode input voltage is not critical as long as it is within the range allowed by the maximum average current of 8 mA because the input is AC-coupled on-chip.
  - This current limitation sets the maximum common mode input voltage to be less than 0.4 V ( $0.4 \text{ V} / 50 = 8 \text{ mA}$ ) while the minimum common mode input level is 0.1 V above  $\text{GND}_{\text{SXC}}$ . For example, a clock with a 50/50 duty cycle can be produced by a clock driver with output driven by its current source from 0 mA to 16 mA (0–0.8 V), such that each phase of the differential input has a single-ended swing from 0 V to 800 mV with the common mode voltage at 400 mV.
  - If the device driving the  $\overline{\text{SD\_REF\_CLK}}[1-2]$  and  $\overline{\text{SD\_REF\_CLK}}[1-2]$  inputs cannot drive 50  $\Omega$  to  $\text{GND}_{\text{SXC}}$  DC or the drive strength of the clock driver chip exceeds the maximum input current limitations, it must be AC-coupled externally.
- The input amplitude requirement is described in detail in the following sections.

### 3.5.2.3 SerDes Transmitter and Receiver Reference Circuits

[Figure 4](#) shows the reference circuits for SerDes data lane transmitter and receiver.

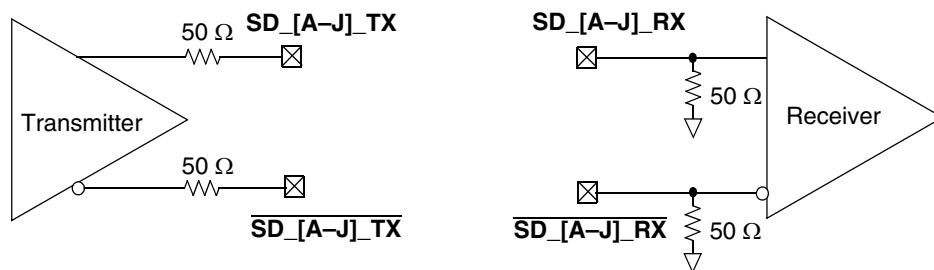

**Note:** The [A–J] indicates the specific SerDes lane. Each lane can be assigned to a specific protocol by the RCW assignments at reset (see the *MSC8157 Reference Manual* for details). External AC coupling capacitors are required for all protocols for all lanes.

**Figure 4. SerDes Transmitter and Receiver Reference Circuits**

### 3.5.2.4 Equalization

With the use of high-speed serial links, the interconnect media causes degradation of the signal at the receiver and produces effects such as inter-symbol interference (ISI) or data-dependent jitter. This loss can be large enough to degrade the eye opening at the receiver beyond that allowed by the specification. To offset a portion of these effects, equalization can be used. The following is a list of the most commonly used equalization techniques:

- Pre-emphasis on the transmitter

- A passive high-pass filter network placed at the receiver, often referred to as passive equalization
- The use of active circuits in the receiver, often referred to as adaptive equalization

### 3.5.3 DC-Level Requirements for SerDes Interfaces

The following subsections define the DC-level requirements for the SerDes reference clocks, the PCI Express data lines, the Serial RapidIO data lines, the CPRI data lines, and the SGMII data lines.

#### 3.5.3.1 DC-Level Requirements for SerDes Reference Clocks

The DC-level requirement for the SerDes reference clock inputs is different depending on the signaling mode used to connect the clock driver chip and SerDes reference clock inputs, as described below:

- Differential Mode
  - The input amplitude of the differential clock must be between 400 mV and 1600 mV differential peak-peak (or between 200 mV and 800 mV differential peak). In other words, each signal wire of the differential pair must have a single-ended swing of less than 800 mV and greater than 200 mV. This requirement is the same for both external DC-coupled or AC-coupled connection.
  - For an external DC-coupled connection, the maximum average current requirements sets the requirement for average voltage (common mode voltage) as between 100 mV and 400 mV. [Figure 5](#) shows the SerDes reference clock input requirement for DC-coupled connection scheme.

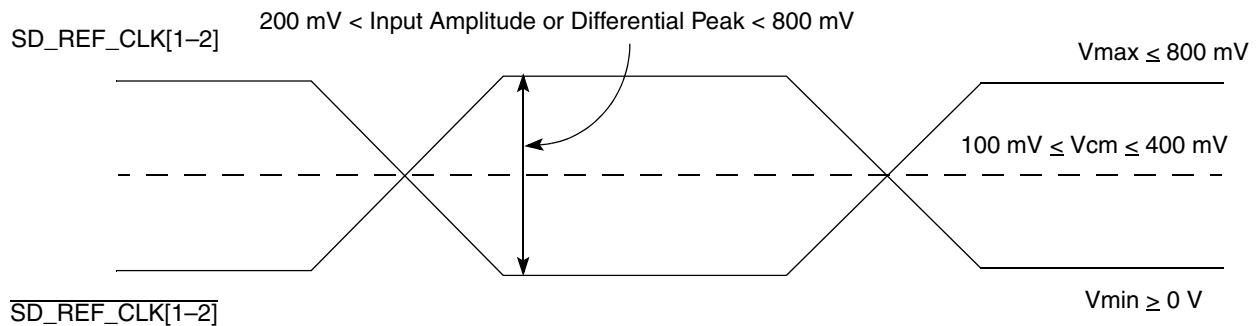

**Figure 5. Differential Reference Clock Input DC Requirements (External DC-Coupled)**

- For an external AC-coupled connection, there is no common mode voltage requirement for the clock driver. Because the external AC-coupling capacitor blocks the DC-level, the clock driver and the SerDes reference clock receiver operate in different command mode voltages. The SerDes reference clock receiver in this connection scheme has its common mode voltage set to  $GND_{SXC}$ . Each signal wire of the differential inputs is allowed to swing below and above the command mode voltage  $GND_{SXC}$ . [Figure 6](#) shows the SerDes reference clock input requirement for AC-coupled connection scheme.

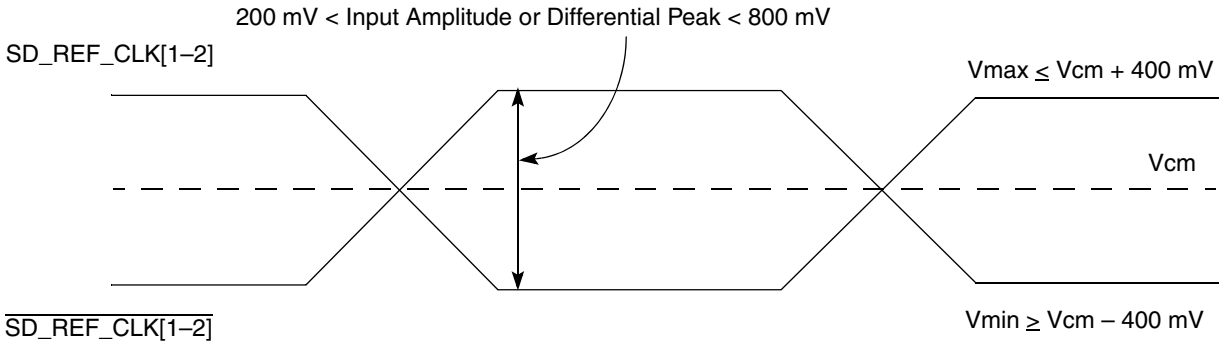

**Figure 6. Differential Reference Clock Input DC Requirements (External AC-Coupled)**

- Single-Ended Mode
  - The reference clock can also be single-ended. The SD\_REF\_CLK[1-2] input amplitude (single-ended swing) must be between 400 mV and 800 mV peak-peak (from  $V_{MIN}$  to  $V_{MAX}$ ) with SD\_REF\_CLK[1-2] either left unconnected or tied to ground.
  - The SD\_REF\_CLK[1-2] input average voltage must be between 200 and 400 mV. Figure 7 shows the SerDes reference clock input requirement for single-ended signaling mode.
  - To meet the input amplitude requirement, the reference clock inputs may need to be DC- or AC-coupled externally. For the best noise performance, the reference of the clock could be DC- or AC-coupled into the unused phase ( $\overline{SD\_REF\_CLK[1-2]}$ ) through the same source impedance as the clock input (SD\_REF\_CLK[1-2]) in use.

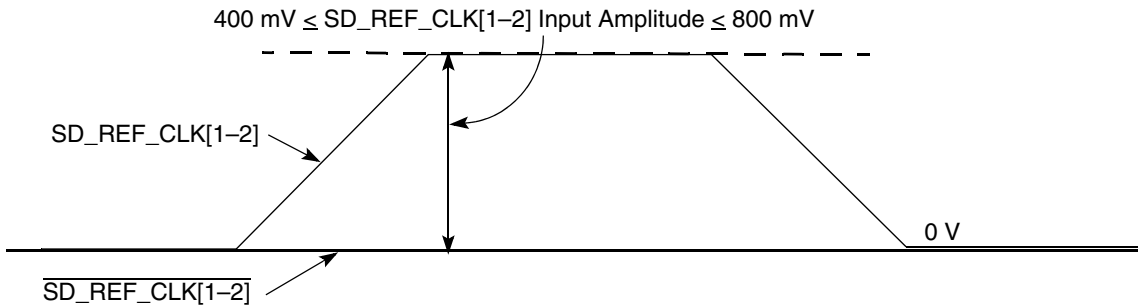

**Figure 7. Single-Ended Reference Clock Input DC Requirements**

### 3.5.3.2 DC-Level Requirements for PCI Express Configurations

The DC-level requirements for PCI Express implementations have separate requirements for the Tx and Rx lines. The MSC8157 supports a 2.5 Gbps and a 5 Gbps PCI Express interface defined by the *PCI Express Base Specification, Revision*

2.0. The transmitter specifications for 2.5 Gbps are defined in [Table 11](#) and the receiver specifications are defined in [Table 12](#). For 5 Gbps, the transmitter specifications are defined in [Table 13](#) and the receiver specifications are defined in [Table 14](#).

**Table 11. PCI Express (2.5 Gbps) Differential Transmitter (Tx) Output DC Specifications**

At recommended operating conditions (see [Table 4](#)).

Parameter	Symbol	Min	Nom	Max	Units	Condition
Differential peak-to-peak output voltage swing	$V_{TX-DIFFp-p}$	800	1000	1200	mV	$V_{TX-DIFFp-p} = 2 \times  V_{TX-D+} - V_{TX-D-} $ , Measured at the package pins with a test load of 50 $\Omega$ to GND on each pin.
De-emphasized differential output voltage (ratio)	$V_{TX-DE-RATIO}$	3.0	3.5	4.0	dB	Ratio of the $V_{TX-DIFFp-p}$ of the second and following bits after a transition divided by the $V_{TX-DIFFp-p}$ of the first bit after a transition. Measured at the package pins with a test load of 50 $\Omega$ to GND on each pin.
DC differential Tx impedance	$Z_{TX-DIFF-DC}$	80	100	120	$\Omega$	Tx DC differential mode low Impedance
DC single-ended TX impedance	$Z_{TX-DC}$	40	50	60	$\Omega$	Required Tx D+ as well as D- DC Impedance during all states

**Table 12. PCI Express (2.5 Gbps) Differential Receiver (Rx) Input DC Specifications**

At recommended operating conditions (see [Table 4](#)).

Parameter	Symbol	Min	Nom	Max	Units	Notes
Differential input peak-to-peak voltage	$V_{RX-DIFFp-p}$	120	1000	1200	mV	1
DC differential Input Impedance	$Z_{RX-DIFF-DC}$	80	100	120	$\Omega$	2
DC input impedance	$Z_{RX-DC}$	40	50	60	$\Omega$	3
Powered down DC input impedance	$Z_{RX-HIGH-IMP-DC}$	50	—	—	$K\Omega$	4
Electrical idle detect threshold	$V_{RX-IDLE-DET-DIFFp-p}$	65	—	175	mV	5

- Notes:**
- $V_{RX-DIFFp-p} = 2 \times |V_{RX-D+} - V_{RX-D-}|$  Measured at the package pins with a test load of 50  $\Omega$  to GND on each pin.
  - Rx DC differential mode impedance. Impedance during all LTSSM states. When transitioning from a fundamental reset to detect (the initial state of the LTSSM), there is a 5 ms transition time before the receiver termination values must be met on all unconfigured lanes of a port.
  - Required Rx D+ as well as D- DC Impedance (50  $\pm$ 20% tolerance). Measured at the package pins with a test load of 50  $\Omega$  to GND on each pin. Impedance during all LTSSM states. When transitioning from a fundamental reset to detect (the initial state of the LTSSM), there is a 5 ms transition time before the receiver termination values must be met on all unconfigured lanes of a port.
  - Required Rx D+ as well as D- DC Impedance when the receiver terminations do not have power. The Rx DC common mode impedance that exists when no power is present or fundamental reset is asserted. This helps ensure that the receiver detect circuit does not falsely assume a receiver is powered on when it is not. This term must be measured at 300 mV above the Rx ground.
  - $V_{RX-IDLE-DET-DIFFp-p} = 2 \times |V_{RX-D+} - V_{RX-D-}|$ . Measured at the package pins of the receiver

## Electrical Characteristics

**Table 13. PCI Express (5 Gbps) Differential Transmitter (Tx) Output DC Specifications**

At recommended operating conditions (see Table 4).

Parameter	Symbol	Min	Nom	Max	Units	Condition
Differential peak-to-peak output voltage swing	$V_{TX-DIFFp-p}$	800	1000	1200	mV	$V_{TX-DIFFp-p} = 2 \times  V_{TX-D+} - V_{TX-D-} $ , Measured at the package pins with a test load of 50 $\Omega$ to GND on each pin.
Low power differential peak-to-peak output voltage swing	$V_{TX-DIFFp-p\_low}$	400	500	1200	mV	$V_{TX-DIFFp-p} = 2 \times  V_{TX-D+} - V_{TX-D-} $ , Measured at the package pins with a test load of 50 $\Omega$ to GND on each pin.
De-emphasized differential output voltage (ratio)	$V_{TX-DE-RATIO-3.5dB}$	3.0	3.5	4.0	dB	Ratio of the $V_{TX-DIFFp-p}$ of the second and following bits after a transition divided by the $V_{TX-DIFFp-p}$ of the first bit after a transition. Measured at the package pins with a test load of 50 $\Omega$ to GND on each pin.
De-emphasized differential output voltage (ratio)	$V_{TX-DE-RATIO-6.0dB}$	5.5	6.0	6.5	dB	Ratio of the $V_{TX-DIFFp-p}$ of the second and following bits after a transition divided by the $V_{TX-DIFFp-p}$ of the first bit after a transition. Measured at the package pins with a test load of 50 $\Omega$ to GND on each pin.
DC differential Tx impedance	$Z_{TX-DIFF-DC}$	80	100	120	$\Omega$	Tx DC differential mode low impedance
Transmitter DC impedance	$Z_{TX-DC}$	40	50	60	$\Omega$	Required Tx D+ as well as D- DC impedance during all states

**Table 14. PCI Express (5 Gbps) Differential Receiver (Rx) Input DC Specifications**

Parameter	Symbol	Min	Nom	Max	Units	Notes
Differential input peak-to-peak voltage	$V_{RX-DIFFp-p}$	120	1000	1200	mV	1
DC differential Input Impedance	$Z_{RX-DIFF-DC}$	80	100	120	$\Omega$	2

**Table 14. PCI Express (5 Gbps) Differential Receiver (Rx) Input DC Specifications (continued)**

Parameter	Symbol	Min	Nom	Max	Units	Notes
DC input impedance	$Z_{RX-DC}$	40	50	60	$\Omega$	3
Powered down DC input impedance	$Z_{RX-HIGH-IMP-DC}$	50	—	—	$K\Omega$	4
Electrical idle detect threshold	$V_{RX-IDLE-DET-DIFFp-p}$	65	—	175	mV	5

- Notes:**
- $V_{RX-DIFFp-p} = 2 \times |V_{RX-D+} - V_{RX-D-}|$  Measured at the package pins with a test load of  $50 \Omega$  to GND on each pin.
  - Rx DC differential mode impedance. Impedance during all LTSSM states. When transitioning from a fundamental reset to detect (the initial state of the LTSSM), there is a 5 ms transition time before the receiver termination values must be met on all unconfigured lanes of a port.
  - Required Rx D+ as well as D– DC Impedance ( $50 \pm 20\%$  tolerance). Measured at the package pins with a test load of  $50 \Omega$  to GND on each pin. Impedance during all LTSSM states. When transitioning from a fundamental reset to detect (the initial state of the LTSSM), there is a 5 ms transition time before the receiver termination values must be met on all unconfigured lanes of a port.
  - Required Rx D+ as well as D– DC Impedance when the receiver terminations do not have power. The Rx DC common mode impedance that exists when no power is present or fundamental reset is asserted. This helps ensure that the receiver detect circuit does not falsely assume a receiver is powered on when it is not. This term must be measured at 300 mV above the Rx ground.
  - $V_{RX-IDLE-DET-DIFFp-p} = 2 \times |V_{RX-D+} - V_{RX-D-}|$ . Measured at the package pins of the receiver

### 3.5.3.3 DC Level Requirements for Serial RapidIO Configurations

**Table 15. Serial RapidIO Transmitter DC Specifications for Transfer Rates  $\leq 3.125$  Gbaud**

At recommended operating conditions (see Table 4).

Parameter	Symbol	Min	Nom	Max	Units	Condition
Output voltage	$V_O$	-0.40	—	2.30	V	—
Long run differential output voltage	$V_{DIFFPP}$	800	—	1600	mVp-p	L[A–J]TECRO[AMP_RED] = 0b000000
Short run differential output voltage	$V_{DIFFPP}$	500	—	1000	mVp-p	L[A–J]TECRO[AMP_RED] = 0b001000
DC differential TX impedance	$Z_{TX-DIFF-DC}$	80	100	120	$\Omega$	—

**Note:** Voltage relative to COMMON of either signal comprising a differential pair.

**Table 16. Serial RapidIO Receiver DC Specifications for Transfer Rates  $\leq 3.125$  Gbaud**

At recommended operating conditions (see Table 4).

Parameter	Symbol	Min	Nom	Max	Units
Differential input voltage	$V_{IN}$	200	—	1600	mVp-p
DC differential RX impedance	$Z_{RX-DIFF-DC}$	80	100	120	$\Omega$

- Notes:**
- Voltage relative to COMMON of either signal comprising a differential pair.
  - Specifications are for Long and Short Run.

## Electrical Characteristics

**Table 17. Serial RapidIO Transmitter DC Specifications for Short Run at 5 Gbaud**

At recommended operating conditions (see Table 4).

Parameter	Symbol	Min	Nom	Max	Units	Condition
Output differential voltage (into floating load Rload = 100 Ω)	T_Vdiff	400	—	750	mV	Amplitude setting L[A–J]TECR0[AMP_RED] = 0b001101
Differential resistance	T_Rd	80	100	120	Ω	—

**Table 18. Serial RapidIO Receiver DC Specifications for Short Run at 5 Gbaud**

At recommended operating conditions (see Table 4).

Parameter	Symbol	Min	Nom	Max	Units
Input differential voltage	R_Vdiff	125	—	1200	mV
Differential resistance	R_Rdin	80	—	120	Ω

**Table 19. Serial RapidIO Transmitter DC Specifications for Long Run at 5 Gbaud**

At recommended operating conditions (see Table 4).

Parameter	Symbol	Min	Nom	Max	Units	Conditions
Output differential voltage (into floating load Rload = 100 Ω)	T_Vdiff	800	—	1200	mV	Amplitude setting L[A–J]TECR0[AMP_RED] = 0b000000 (with de-emphasis disabled)
De-emphasized differential output voltage	T_VTX-DE-RATIO-3.5dB	3	3.5	4	dB	<ul style="list-style-type: none"> <li>p(n)(y)_tx_eq_type[1:0] = 01</li> <li>p(n)(y)_tx_ratio_post1q[3:0] = 1110</li> </ul>
Tx De-emphasized level	T_VTX-DE-RATIO-6.0dB	5.5	6	6.5	dB	<ul style="list-style-type: none"> <li>p(n)(y)_tx_eq_type[1:0] = 01</li> <li>p(n)(y)_tx_ratio_post1q[3:0] = 1100</li> </ul>
Differential resistance	T_Rd	80	100	120	Ω	—

**Table 20. Serial RapidIO Receiver DC Specifications for Long Run at 5 Gbaud**

At recommended operating conditions (see Table 4).

Parameter	Symbol	Min	Nom	Max	Units	Condition
Input differential voltage	R_Vdiff	N/A	—	1200	mV	It is assumed that for the R_Vdiff min specification, that the eye can be closed at the receiver after passing the signal through a CEI/SRIO Level II LR compliant channel.
Differential resistance	R_Rdin	80	—	120	Ω	—



### 3.5.3.4 DC-Level Requirements for CPRI Configurations

This section provide various DC-level requirements for CPRI configurations.

**Table 21. CPRI Transmitter DC Specifications (LV: 1.2288, 2.4576 and 3.072 Gbps)**

At recommended operating conditions (see Table 4).

Parameter	Symbol	Min	Nom	Max	Units	Condition
Output voltage	$V_O$	-0.40	—	2.30	V	Voltage relative to COMMON of either signal comprising a differential pair.
Differential output voltage	$V_{DIFFPP}$	800	—	1600	mVp-p	L[A~J]TECR0[AMP_RED] = 0b000000.
Differential resistance	$T_{Rd}$	80	100	120	$\Omega$	—

**Note:** LV is XAUI-based.

**Table 22. CPRI Transmitter DC Specifications (LV-II: 1.2288, 2.4576, 3.072, 4.9152, and 6.144 Gbps)**

At recommended operating conditions (see Table 4).

Parameter	Symbol	Min	Nom	Max	Units	Condition
Output differential voltage (into floating load $R_{load} = 100 \Omega$ )	$T_{Vdiff}$	800	—	1200	mV	L[A~J]TECR0[AMP_RED] = 0x000000
Differential resistance	$T_{Rd}$	80	100	120	$\Omega$	—

**Note:** LV-II is CEI-6G-LR-based.

**Table 23. CPRI Receiver DC Specifications (LV: 1.2288, 2.4576 and 3.072 Gbps)**

At recommended operating conditions (see Table 4).

Parameter	Symbol	Min	Nom	Max	Units	Condition
Differential input voltage	$V_{IN}$	200	—	1600	mVp-p	Measured at receiver.
Difference resistance	$R_{Rdin}$	80	—	120	$\Omega$	—

**Note:** LV is XAUI-based.

**Table 24. CPRI Receiver DC Specifications (LV-II: 1.2288, 2.4576, 3.072, 4.9152, and 6.144 Gbps)**

At recommended operating conditions (see Table 4).

Parameter	Symbol	Min	Nom	Max	Units	Condition
Input differential voltage	$R_{Vdiff}$	N/A	—	1200	mV	It is assumed that for the $R_{Vdiff}$ min specification, that the eye can be closed at the receiver after passing the signal through a CEI/CPRI Level II LR compliant channel.
Differential resistance	$R_{Rdin}$	80	—	120	$\Omega$	—

**Note:** LV-II is CEI-6G-LR-based.

### 3.5.3.5 DC-Level Requirements for SGMII Configurations

Table 25 describes the SGMII SerDes transmitter AC-coupled DC electrical characteristics.

**Table 25. SGMII DC Transmitter Electrical Characteristics**

At recommended operating conditions (see Table 4).

Parameter	Symbol	Min	Nom	Max	Unit	Conditions
Output differential voltage	$ V_{OD} $	$0.64 \times \text{Nom}$	500	$1.45 \times \text{Nom}$	mV	<ol style="list-style-type: none"> <li>The <math> V_{OD} </math> value shown in the Typ column is based on the condition of <math>XV_{DD\_SRDS2-Typ}=1.0</math> V, no common mode offset variation (<math>V_{OS}=500\text{mV}</math>), SerDes transmitter is terminated with <math>100\text{-}\Omega</math> differential load between <math>\text{SD\_TXn}</math> and <math>\overline{\text{SD\_TXn}}</math>.</li> <li>Amplitude setting: [A-J]TECR0[AMD_RED] = 0b000000</li> </ol>
Output differential voltage	$ V_{OD} $	$0.64 \times \text{Nom}$	459	$1.45 \times \text{Nom}$	mV	<ol style="list-style-type: none"> <li>The <math> V_{OD} </math> value shown in the Typ column is based on the condition of <math>XV_{DD\_SRDS2-Typ}=1.0\text{V}</math>, no common mode offset variation (<math>V_{OS}=500\text{mV}</math>), SerDes transmitter is terminated with <math>100\text{-}\Omega</math> differential load between <math>\text{SD\_TXn}</math> and <math>\overline{\text{SD\_TXn}}</math>.</li> <li>Amplitude setting: [A-J]TECR0[AMD_RED] = 0b000010</li> </ol>
Output differential voltage	$ V_{OD} $	$0.64 \times \text{Nom}$	417	$1.45 \times \text{Nom}$	mV	<ol style="list-style-type: none"> <li>The <math> V_{OD} </math> value shown in the Typ column is based on the condition of <math>XV_{DD\_SRDS2-Typ}=1.0\text{V}</math>, no common mode offset variation (<math>V_{OS}=500\text{mV}</math>), SerDes transmitter is terminated with <math>100\text{-}\Omega</math> differential load between <math>\text{SD\_TXn}</math> and <math>\overline{\text{SD\_TXn}}</math>.</li> <li>Amplitude setting: [A-J]TECR0[AMD_RED] = 0b000101</li> </ol>
Output differential voltage	$ V_{OD} $	$0.64 \times \text{Nom}$	376	$1.45 \times \text{Nom}$	mV	<ol style="list-style-type: none"> <li>The <math> V_{OD} </math> value shown in the Typ column is based on the condition of <math>XV_{DD\_SRDS2-Typ}=1.0\text{V}</math>, no common mode offset variation (<math>V_{OS}=500\text{mV}</math>), SerDes transmitter is terminated with <math>100\text{-}\Omega</math> differential load between <math>\text{SD\_TXn}</math> and <math>\overline{\text{SD\_TXn}}</math>.</li> <li>Amplitude setting: [A-J]TECR0[AMD_RED] = 0b001000</li> </ol>
Output differential voltage	$ V_{OD} $	$0.64 \times \text{Nom}$	333	$1.45 \times \text{Nom}$	mV	<ol style="list-style-type: none"> <li>The <math> V_{OD} </math> value shown in the Typ column is based on the condition of <math>XV_{DD\_SRDS2-Typ}=1.0\text{V}</math>, no common mode offset variation (<math>V_{OS}=500\text{mV}</math>), SerDes transmitter is terminated with <math>100\text{-}\Omega</math> differential load between <math>\text{SD\_TXn}</math> and <math>\overline{\text{SD\_TXn}}</math>.</li> <li>Amplitude setting: [A-J]TECR0[AMD_RED] = 0b001100</li> </ol>

**Table 25. SGMII DC Transmitter Electrical Characteristics (continued)**

At recommended operating conditions (see Table 4).

Parameter	Symbol	Min	Nom	Max	Unit	Conditions
Output differential voltage	$ V_{OD} $	$0.64 \times \text{Nom}$	292	$1.45 \times \text{Nom}$	mV	1. The $ V_{OD} $ value shown in the Typ column is based on the condition of $XV_{DD\_SRDS2-Typ}=1.0V$ , no common mode offset variation ( $V_{OS}=500mV$ ), SerDes transmitter is terminated with 100- $\Omega$ differential load between $SD\_TXn$ and $SD\_TX\bar{n}$ . 2. Amplitude setting: $[A-J]TECR0[AMD\_RED] = 0b001111$
Output differential voltage	$ V_{OD} $	$0.64 \times \text{Nom}$	250	$1.45 \times \text{Nom}$	mV	1. The $ V_{OD} $ value shown in the Typ column is based on the condition of $XV_{DD\_SRDS2-Typ}=1.0V$ , no common mode offset variation ( $V_{OS}=500mV$ ), SerDes transmitter is terminated with 100- $\Omega$ differential load between $SD\_TXn$ and $SD\_TX\bar{n}$ . 2. Amplitude setting: $[A-J]TECR0[AMD\_RED] = 0b010011$
Output impedance (single-ended)	$R_O$	40	50	60	$\Omega$	—
Output high voltage	$V_{OH}$	—	—	$1.5 \times  V_{OD} , \text{max}$	mV	—
Output low voltage	$V_{OL}$	$ V_{OD} , \text{min}/2$	—	—	mV	—

## Electrical Characteristics

Table 26 describes the SGMII SerDes receiver AC-coupled DC electrical characteristics.

**Table 26. SGMII DC Receiver Electrical Characteristics<sup>1,2</sup>**

At recommended operating conditions (see Table 4).

Parameter	Symbol	Min	Nom	Max	Unit	Condition
Input differential voltage <sup>3</sup>	$V_{RX\_DIFFp-p}$	100	—	1200	mV	L[A–J]GCR1[RECTL_SIGD] = 0b001
		175	—	1200	mV	L[A–J]GCR1[RECTL_SIGD] = 0b100
Loss of signal threshold <sup>4</sup>	VLOS	30	—	100	mV	L[A–J]GCR1[RECTL_SIGD] = 0b001
		65	—	175	mV	L[A–J]GCR1[RECTL_SIGD] = 0b100
Receiver differential input impedance	$Z_{RX\_DIFF}$	80	—	120	$\Omega$	—

- Notes:**
1. The supply voltage is 1.0 V.
  2. Input must be externally AC-coupled.
  3.  $V_{RX\_DIFFp-p}$  is also referred to as peak-to-peak input differential voltage.
  4. The concept of this parameter is equivalent to the Electrical Idle Detect Threshold parameter in the PCI Express interface. Refer to the PCI Express Differential Receiver (RX) Input Specifications section of the *PCI Express Specification* document. for details.

### 3.5.4 RGMII and Other Interface DC Electrical Characteristics

Table 27 describes the DC electrical characteristics for the following interfaces:

- RGMII Ethernet
- SPI
- GPIO
- UART
- TIMER
- EE
- I<sup>2</sup>C
- Interrupts ( $\overline{IRQn}$ ,  $\overline{NMI\_OUT/CP\_RX\_INT}$ ,  $\overline{INT\_OUT/CP\_TX\_INT}$ )
- Clock and resets ( $\overline{CLKIN/MCLKIN}$ ,  $\overline{PORESET}$ ,  $\overline{HRESET}$ ,  $\overline{HRESET\_IN}$ )
- DMA External Request
- JTAG signals

**Table 27. 2.5 V I/O DC Electrical Characteristics**

Characteristic	Symbol	Min	Max	Unit	Notes
Input high voltage	$V_{IH}$	1.7	—	V	1
Input low voltage	$V_{IL}$	—	0.7	V	1
Input high current ( $V_{IN} = V_{DDIO}$ )	$I_{INH}$	—	30	$\mu$ A	2
Input low current ( $V_{IN} = GND$ )	$I_{INL}$	–30	—	$\mu$ A	2
Output high voltage ( $V_{DDIO} = \text{min}$ , $I_{OH} = -1.0 \text{ mA}$ )	$V_{OH}$	2.0	$V_{DDIO} + 0.3$	V	1
Output low voltage ( $V_{DDIO} = \text{min}$ , $I_{OL} = 1.0 \text{ mA}$ )	$V_{OL}$	$GND - 0.3$	0.40	V	1

- Notes:**
1. The min  $V_{IL}$  and max  $V_{IH}$  values are based on the respective min and max  $V_{IN}$  values listed in Table 4.
  2. The symbol  $V_{IN}$  represents the input voltage of the supply. It is referenced in Table 4.

## 3.6 AC Timing Characteristics

This section describes the AC timing characteristics for the MSC8157.

### 3.6.1 DDR SDRAM AC Timing Specifications

This section describes the AC electrical characteristics for the DDR SDRAM interface.

#### 3.6.1.1 DDR SDRAM Input AC Timing Specifications

Table 28 provides the input AC timing specifications for the DDR SDRAM when  $V_{DDDDR}(\text{typ}) = 1.5\text{ V}$ .

**Table 28. DDR3 SDRAM Input AC Timing Specifications for 1.5 V Interface**

Parameter	Symbol	Min	Max	Unit
AC input low voltage > 1200 MHz data rate ≤ 1200 MHz data rate	$V_{ILAC}$	—	$MV_{REF} - 0.150$ $MV_{REF} - 0.175$	V
AC input high voltage > 1200 MHz data rate ≤ 1200 MHz data rate	$V_{IHAC}$	$MV_{REF} + 0.150$ $MV_{REF} + 0.175$	—	V

**Note:** At recommended operating conditions with  $V_{DDDDR}$  of  $1.5 \pm 5\%$ .

Table 29 provides the input AC timing specifications for the DDR SDRAM interface.

**Table 29. DDR SDRAM Input AC Timing Specifications**

Parameter	Symbol	Min	Max	Unit	Notes
Controller Skew for MDQS—MDQ/MECC • 1333 MHz data rate • 1200 MHz data rate • 1066 MHz data rate • 800 MHz data rate • 667 MHz data rate	$t_{CISKEW}$	-125 -142 -170 -200 -240	125 142 170 200 240	ps ps ps ps ps	1, 2, 4
Tolerated Skew for MDQS—MDQ/MECC • 1333 MHz data rate • 1200 MHz data rate • 1066 MHz data rate • 800 MHz data rate • 667 MHz data rate	$t_{DISKEW}$	-250 -275 -300 -425 -510	250 275 300 425 510	ps ps ps ps ps	2, 3

- Notes:**
- $t_{CISKEW}$  represents the total amount of skew consumed by the controller between MDQS[n] and any corresponding bit that is captured with MDQS[n]. Subtract this value from the total timing budget.
  - At recommended operating conditions with  $V_{DDDDR} (1.5\text{ V}) \pm 5\%$
  - The amount of skew that can be tolerated from MDQS to a corresponding MDQ signal is called  $t_{DISKEW}$ . This can be determined by the following equation:  $t_{DISKEW} = \pm(T \div 4 - \text{abs}(t_{CISKEW}))$  where T is the clock period and  $\text{abs}(t_{CISKEW})$  is the absolute value of  $t_{CISKEW}$ .
  - The  $t_{CISKEW}$  test coverage is derived from the  $t_{DISKEW}$  parameters.

## Electrical Characteristics

Figure 8 shows the DDR3 SDRAM interface input timing diagram.

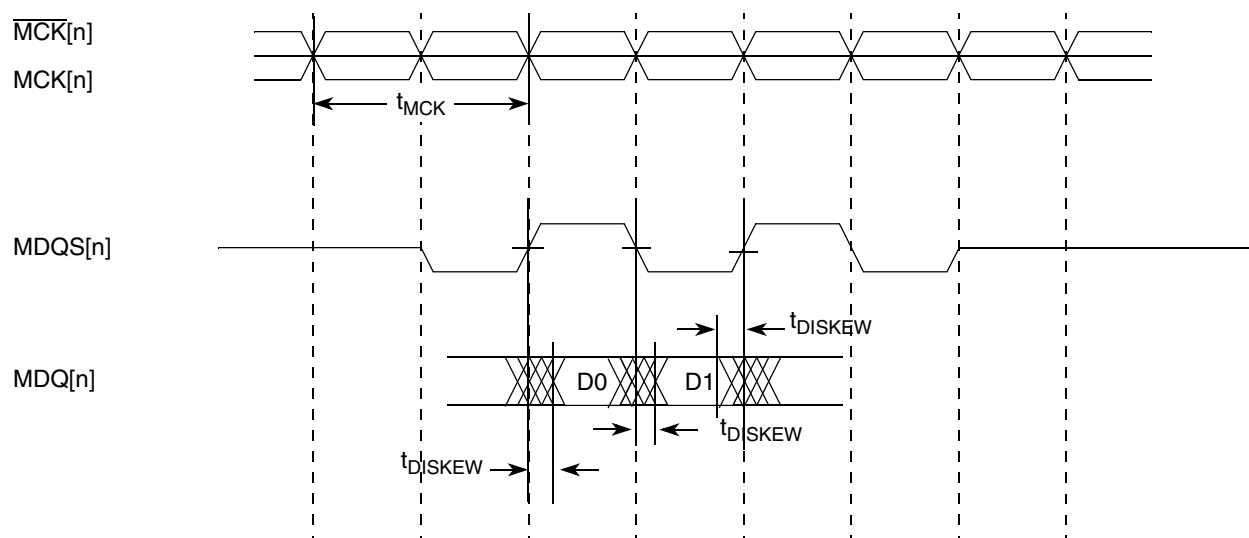

Figure 8. DDR3 SDRAM Interface Input Timing Diagram

### 3.6.1.2 DDR SDRAM Output AC Timing Specifications

Table 30 provides the output AC timing specifications for the DDR SDRAM interface.

Table 30. DDR SDRAM Output AC Timing Specifications

Parameter	Symbol <sup>1</sup>	Min	Max	Unit	Notes
MCK[n] cycle time	$t_{MCK}$	1.5	3	ns	2
ADDR/CMD output setup with respect to MCK • 1333 MHz data rate • 1200 MHz data rate • 1066 MHz data rate • 800 MHz data rate • 667 MHz data rate	$t_{DDKHAS}$	0.606 0.675 0.744 0.917 1.10	—	ns	3
ADDR/CMD output hold with respect to MCK • 1333 MHz data rate • 1200 MHz data rate • 1066 MHz data rate • 800 MHz data rate • 667 MHz data rate	$t_{DDKHAX}$	0.606 0.675 0.744 0.917 1.10	—	ns	3
MCSn output setup with respect to MCK • 1333 MHz data rate • 1200 MHz data rate • 1066 MHz data rate • 800 MHz data rate • 667 MHz data rate	$t_{DDKHCS}$	0.606 0.675 0.744 0.917 1.10	—	ns	3

Table 30. DDR SDRAM Output AC Timing Specifications (continued)

Parameter	Symbol <sup>1</sup>	Min	Max	Unit	Notes
MCSn output hold with respect to MCK <ul style="list-style-type: none"> <li>• 1333 MHz data rate</li> <li>• 1200 MHz data rate</li> <li>• 1066 MHz data rate</li> <li>• 800 MHz data rate</li> <li>• 667 MHz data rate</li> </ul>	$t_{DDKHGX}$	0.606 0.675 0.744 0.917 1.10	— — — — —	ns ns ns ns ns	3
MCK to MDQS Skew <ul style="list-style-type: none"> <li>• &gt; 1066 MHz data rate</li> <li>• 800 MHz data rate</li> <li>• 667 MHz data rate</li> </ul>	$t_{DDKHMH}$	-0.245 -0.375 -0.6	0.245 0.375 0.6	ns ns ns	4
MDQ/MECC/MDM output setup with respect to MDQS <ul style="list-style-type: none"> <li>• 1333 MHz data rate</li> <li>• 1200 MHz data rate</li> <li>• 1066 MHz data rate</li> <li>• 800 MHz data rate</li> <li>• 667 MHz data rate</li> </ul>	$t_{DDKHDS}$ , $t_{DDKLDS}$	250 275 300 375 450	— — — — —	ps ps ps ps ps	5, 6
MDQ/MECC/MDM output hold with respect to MDQS <ul style="list-style-type: none"> <li>• 1333 MHz data rate</li> <li>• 1200 MHz data rate</li> <li>• 1066 MHz data rate</li> <li>• 800 MHz data rate</li> <li>• 667 MHz data rate</li> </ul>	$t_{DDKHDX}$ , $t_{DDKLDX}$	250 275 300 375 450	— — — — —	ps ps ps ps ps	5
MDQS preamble	$t_{DDKHMP}$	$0.9 \times t_{MCK}$	—	ns	—
MDQS postamble	$t_{DDKHME}$	$0.4 \times t_{MCK}$	$0.6 \times t_{MCK}$	ns	—

- Notes:**
1. The symbols used for timing specifications follow the pattern of  $t_{(\text{first two letters of functional block})(\text{signal})(\text{state})(\text{reference})(\text{state})}$  for inputs and  $t_{(\text{first two letters of functional block})(\text{reference})(\text{state})(\text{signal})(\text{state})}$  for outputs. Output hold time can be read as DDR timing (DD) from the rising or falling edge of the reference clock (KH or KL) until the output went invalid (AX or DX). For example,  $t_{DDKHAS}$  symbolizes DDR timing (DD) for the time  $t_{MCK}$  memory clock reference (K) goes from the high (H) state until outputs (A) are setup (S) or output valid time. Also,  $t_{DDKLDX}$  symbolizes DDR timing (DD) for the time  $t_{MCK}$  memory clock reference (K) goes low (L) until data outputs (D) are invalid (X) or data output hold time.
  2. All  $MCK/\overline{MCK}$  referenced measurements are made from the crossing of the two signals.
  3. ADDR/CMD includes all DDR SDRAM output signals except  $MCK/\overline{MCK}$ ,  $\overline{MCS}$ , and MDQ/MECC/MDM/MDQS.
  4. Note that  $t_{DDKHMH}$  follows the symbol conventions described in note 1. For example,  $t_{DDKHMH}$  describes the DDR timing (DD) from the rising edge of the MCK(n) clock (KH) until the MDQS signal is valid (MH).  $t_{DDKHMH}$  can be modified through control of the DQSS override bits in the TIMING\_CFG\_2 register. This is typically set to the same delay as the clock adjust in the CLK\_CNTL register. The timing parameters listed in the table assume that these two parameters have been set to the same adjustment value. See the *MSC8157 Reference Manual* for a description and understanding of the timing modifications enabled by use of these bits.
  5. Determined by maximum possible skew between a data strobe (MDQS) and any corresponding bit of data (MDQ), ECC (MECC), or data mask (MDM). The data strobe should be centered inside of the data eye at the pins of the MSC8157.
  6. At recommended operating conditions with  $V_{DDDDR}$  (1.5 V)  $\pm$  5%.

### NOTE

For the ADDR/CMD setup and hold specifications in Table 30, it is assumed that the clock control register is set to adjust the memory clocks by  $\frac{1}{2}$  applied cycle.





Figure 11 provides the AC test load for the DDR3 controller bus.

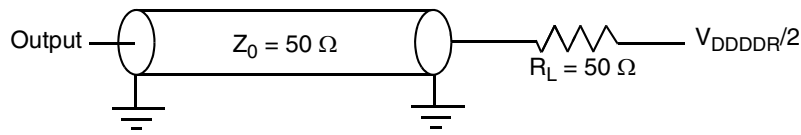

Figure 11. DDR3 Controller Bus AC Test Load

### 3.6.1.3 DDR3 SDRAM Differential Timing Specifications

This section describes the DC and AC differential timing specifications for the DDR3 SDRAM controller interface. Figure 12 shows the differential timing specification.

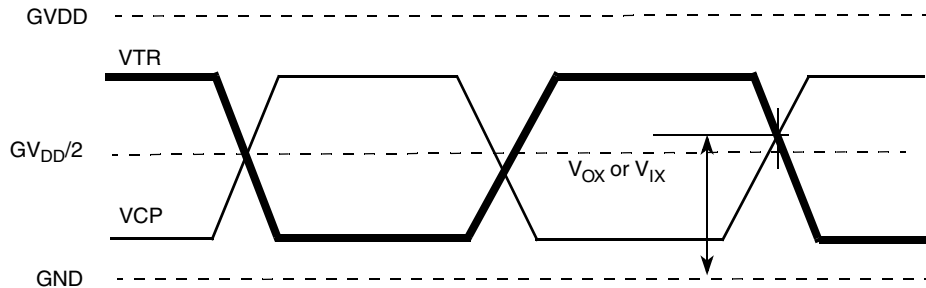

Figure 12. DDR3 SDRAM Differential Timing Specifications

#### NOTE

VTR specifies the true input signal (such as MCK or MDQS) and VCP is the complementary input signal (such as  $\overline{\text{MCK}}$  or  $\overline{\text{MDQS}}$ ).

Table 31 provides the DDR3 differential specifications for the differential signals  $\overline{\text{MDQS}}/\overline{\text{MDQS}}$  and  $\overline{\text{MCK}}/\overline{\text{MCK}}$ .

Table 31. DDR3 SDRAM Differential Electrical Characteristics

Parameter	Symbol	Min	Max	Unit
Input AC differential cross-point voltage	$V_{IXAC}$	$0.5 \times V_{DDDDR} - 0.150$	$0.5 \times V_{DDDDR} + 0.150$	V
Output AC differential cross-point voltage	$V_{OXAC}$	$0.5 \times V_{DDDDR} - 0.115$	$0.5 \times V_{DDDDR} + 0.115$	V

**Note:** I/O drivers are calibrated before making measurements.

### 3.6.2 HSSI AC Timing Specifications

The following subsections define the AC timing requirements for the SerDes reference clocks, the PCI Express data lines, the Serial RapidIO data lines, and the SGMII data lines.

## Electrical Characteristics

### 3.6.2.1 AC Requirements for SerDes Reference Clock

Table 32 lists AC requirements for the SerDes reference clocks.

**Table 32. SD\_REF\_CLK[1–2] and  $\overline{\text{SD\_REF\_CLK}}$ [1–2] Input Clock Requirements**

At recommended operating conditions (see Table 4).

Parameter	Symbol	Min	Nom	Max	Units	Notes
SD_REF_CLK[1–2]/ $\overline{\text{SD\_REF\_CLK}}$ [1–2] frequency range	$t_{\text{CLK\_REF}}$	—	100/125 CPRI: 122.88	—	MHz	1
SD_REF_CLK[1–2]/ $\overline{\text{SD\_REF\_CLK}}$ [1–2] clock frequency tolerance • Serial RapidIO, CPRI, SGMII • PCI Express interface	$t_{\text{CLK\_TOL}}$	–100 –300	— —	100 300	ppm ppm	—
SD_REF_CLK[1–2]/ $\overline{\text{SD\_REF\_CLK}}$ [1–2] reference clock duty cycle	$t_{\text{CLK\_DUTY}}$	40	50	60	%	4
SD_REF_CLK[1–2]/ $\overline{\text{SD\_REF\_CLK}}$ [1–2] max deterministic peak-peak jitter at $10^{-6}$ BER	$t_{\text{CLK\_DJ}}$	—	—	42	ps	—
SD_REF_CLK[1–2]/ $\overline{\text{SD\_REF\_CLK}}$ [1–2] total reference clock jitter at $10^{-6}$ BER (peak-to-peak jitter at ref_clk input)	$t_{\text{CLK\_TJ}}$	—	—	86	ps	2
SD_REF_CLK/ $\overline{\text{SD\_REF\_CLK}}$ rising/falling edge rate	$t_{\text{CLKRR}}/t_{\text{CLKFR}}$	1	—	4	V/ns	3
Differential input high voltage	$V_{\text{IH}}$	200	—	—	mV	4
Differential input low voltage	$V_{\text{IL}}$	—	—	–200	mV	4
Rising edge rate (SD_REF_CLK $_n$ to falling edge rate)	Rise-Fall	—	—	20	%	5, 6

- Notes:**
- Only 100, 122.88, and 125 MHz have been tested. CPRI uses 122.88 MHz. The other interfaces use 100 or 125 MHz. Other values do not work correctly with the rest of the system.
  - Limits are from PCI Express CEM Rev 2.0.
  - Measured from –200 mV to +200 mV on the differential waveform (derived from SD\_REF\_CLK $_n$  minus  $\overline{\text{SD\_REF\_CLK}}_n$ ). The signal must be monotonic through the measurement region for rise and fall time. The 400 mV measurement window is centered on the differential zero crossing. See Figure 13.
  - Measurement taken from differential waveform.
  - Measurement taken from single-ended waveform.
  - Matching applies to rising edge for SD\_REF\_CLK $_n$  and falling edge rate for  $\overline{\text{SD\_REF\_CLK}}_n$ . It is measured using a 200 mV window centered on the median cross point where SD\_REF\_CLK $_n$  rising meets  $\overline{\text{SD\_REF\_CLK}}_n$  falling. The median cross point is used to calculate the voltage thresholds that the oscilloscope uses for the edge rate calculations. The rising edge rate of SD\_REF\_CLK $_n$  should be compared to the falling edge rate of  $\overline{\text{SD\_REF\_CLK}}_n$ ; the maximum allowed difference should not exceed 20% of the slowest edge rate. See Figure 14.
  - REF\_CLK jitter must be less than 0.05 UI when measured against a Golden PLL reference. The Golden PLL must have a maximum baud rate bandwidth greater than 1667, with a maximum 20 dB/dec rolloff down to a baud rate of 16.67 with no peaking around the corner frequency.

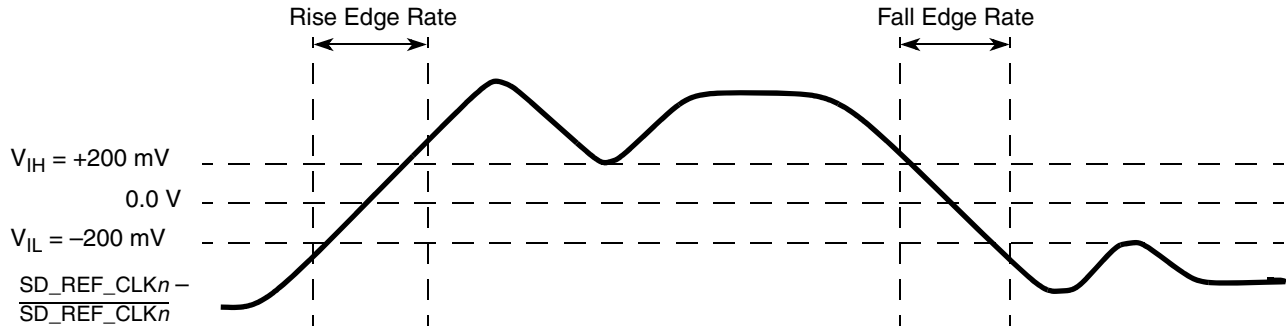

Figure 13. Differential Measurement Points for Rise and Fall Time

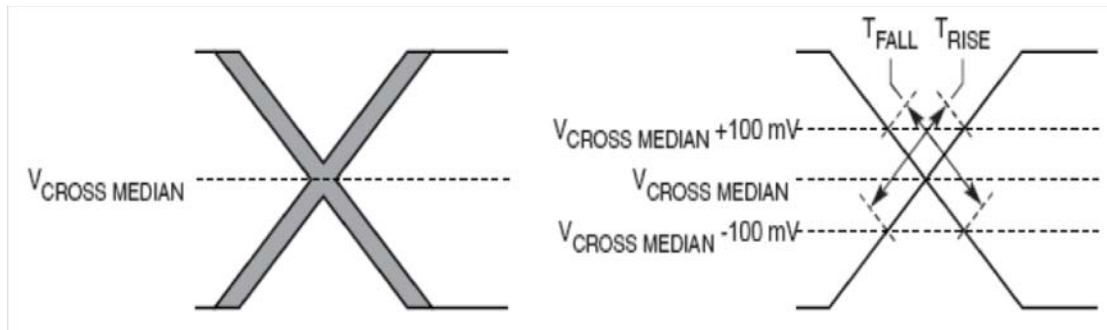

Figure 14. Single-Ended Measurement Points for Rise and Fall Time Matching

### 3.6.2.2 Spread Spectrum Clock

$\overline{\text{SD\_REF\_CLK}}[1-2]$  and  $\overline{\text{SD\_REF\_CLK}}[1-2]$  were designed to work with a spread spectrum clock (+0 to 0.5% spreading at 30–33 KHz rate is allowed), assuming both ends have the same reference clock and the industry protocol supports it. For better results, use a source without significant unintended modulation.

### 3.6.2.3 PCI Express AC Physical Layer Specifications

The AC requirements for PCI Express implementations have separate requirements for the Tx and Rx lines. The MSC8157 supports a 2.5 Gbps or a 5.0 Gbps PCI Express interface defined by the *PCI Express Base Specification, Revision 2.0*. The 2.5 Gbps transmitter specifications are defined in [Table 33](#) and the receiver specifications are defined in [Table 34](#). The 5.0 Gbps

## Electrical Characteristics

transmitter specifications are defined in [Table 35](#) and the receiver specifications are defined in [Table 36](#). The parameters are specified at the component pins. the AC timing specifications do not include REF\_CLK jitter.

**Table 33. PCI Express 2.0 (2.5 Gbps) Differential Transmitter (Tx) Output AC Specifications**

At recommended operating conditions (see [Table 4](#)).

Parameter	Symbol	Min	Nom	Max	Units	Comments
Unit interval	UI	399.88	400.00	400.12	ps	Each UI is 400 ps $\pm$ 300 ppm. UI does not account for spread spectrum clock dictated variations. See note 1.
Tx eye width	$T_{TX-EYE}$	0.75	—	—	UI	The maximum transmitter jitter can be derived as $T_{TX-MAX-JITTER} = 1 - T_{TX-EYE} = 0.25$ UI. This does not include spread spectrum or REF_CLK jitter. It includes device random jitter at $10^{-12}$ . See notes 2 and 3.
Time between the jitter median and maximum deviation from the median.	$T_{TX-EYE-MEDIAN-to-MAX-JITTER}$	—	—	0.125	UI	Jitter is defined as the measurement variation of the crossing points ( $V_{TX-DIFFp-p} = 0$ V) in relation to a recovered Tx UI. A recovered Tx UI is calculated over 3500 consecutive unit intervals of sample data. Jitter is measured using all edges of the 250 consecutive UI in the center of the 3500 UI used for calculating the Tx UI. See notes 2 and 3.
AC coupling capacitor	$C_{TX}$	75	—	200	nF	All transmitters must be AC coupled. The AC coupling is required either within the media or within the transmitting component itself. See note 4.

- Notes:**
1. No test load is necessarily associated with this value.
  2. Specified at the measurement point into a timing and voltage test load as shown in [Figure 15](#) and measured over any 250 consecutive Tx UIs.
  3. A  $T_{TX-EYE} = 0.75$  UI provides for a total sum of deterministic and random jitter budget of  $T_{TX-MAX-JITTER} = 0.25$  UI for the transmitter collected over any 250 consecutive Tx UIs. The  $T_{TX-EYE-MEDIAN-to-MAX-JITTER}$  median is less than half of the total Tx jitter budget collected over any 250 consecutive Tx UIs. It should be noted that the median is not the same as the mean. The jitter median describes the point in time where the number of jitter points on either side is approximately equal as opposed to the averaged time value.
  4. The DSP device SerDes transmitter does not have a built-in  $C_{TX}$ . An external AC coupling capacitor is required.

**Table 34. PCI Express 2.0 (2.5 Gbps) Differential Receiver (Rx) Input AC Specifications**

At recommended operating conditions (see Table 4).

Parameter	Symbol	Min	Nom	Max	Units	Comments
Unit Interval	UI	399.88	400.00	400.12	ps	Each UI is 400 ps $\pm$ 300 ppm. UI does not account for spread spectrum clock dictated variations. See note 1.
Minimum receiver eye width	$T_{RX-EYE}$	0.4	—	—	UI	The maximum interconnect media and Transmitter jitter that can be tolerated by the Receiver can be derived as $T_{RX-MAX-JITTER} = 1 - T_{RX-EYE} = 0.6$ UI. See notes 2 and 3.
Maximum time between the jitter median and maximum deviation from the median.	$T_{RX-EYE-MEDIAN-to-MAX-JITTER}$	—	—	0.3	UI	Jitter is defined as the measurement variation of the crossing points ( $V_{RX-DIFFp-p} = 0$ V) in relation to a recovered Tx UI. A recovered Tx UI is calculated over 3500 consecutive unit intervals of sample data. Jitter is measured using all edges of the 250 consecutive UI in the center of the 3500 UI used for calculating the Tx UI. See notes 2, 3, and 4.

- Notes:**
1. No test load is necessarily associated with this value.
  2. Specified at the measurement point and measured over any 250 consecutive UIs. The test load in Figure 15 should be used as the Rx device when taking measurements. If the clocks to the Rx and Tx are not derived from the same reference clock, the Tx UI recovered from 3500 consecutive UI must be used as a reference for the eye diagram.
  3. A  $T_{RX-EYE} = 0.40$  UI provides for a total sum of 0.60 UI deterministic and random jitter budget for the Transmitter and interconnect collected any 250 consecutive UIs. The  $T_{RX-EYE-MEDIAN-to-MAX-JITTER}$  specification ensures a jitter distribution in which the median and the maximum deviation from the median is less than half of the total. UI jitter budget collected over any 250 consecutive Tx UIs. It should be noted that the median is not the same as the mean. The jitter median describes the point in time where the number of jitter points on either side is approximately equal as opposed to the averaged time value. If the clocks to the Rx and Tx are not derived from the same reference clock, the Tx UI recovered from 3500 consecutive UI must be used as the reference for the eye diagram.
  4. It is recommended that the recovered Tx UI is calculated using all edges in the 3500 consecutive UI interval with a fit algorithm using a minimization merit function. Least squares and median deviation fits have worked well with experimental and simulated data.

## Electrical Characteristics

**Table 35. PCI Express 2.0 (5.0 Gbps) Differential Transmitter (Tx) Output AC Specifications**

At recommended operating conditions (see Table 4).

Parameter	Symbol	Min	Nom	Max	Units	Comments
Unit Interval	UI	199.94	200.00	200.06	ps	Each UI is 400 ps $\pm$ 300 ppm. UI does not account for spread spectrum clock dictated variations. See note 1.
Minimum Tx eye width	$T_{TX-EYE}$	0.75	—	—	UI	The maximum Transmitter jitter can be derived as: $T_{TX-MAX-JITTER} = 1 - T_{TX-EYE} = 0.25$ UI. See notes 2 and 3.
Tx RMS deterministic jitter > 1.5 MHz	$T_{TX-HF-DJ-DD}$	—	—	0.15	ps	—
Tx RMS deterministic jitter < 1.5 MHz	$T_{TX-LF-RMS}$	—	3.0	—	ps	Reference input clock RMS jitter (< 1.5 MHz) at pin < 1 ps
AC coupling capacitor	$C_{TX}$	75	—	200	nF	All transmitters must be AC coupled. The AC coupling is required either within the media or within the transmitting component itself. See note 4.

- Notes:**
1. No test load is necessarily associated with this value.
  2. Specified at the measurement point into a timing and voltage test load as shown in Figure 15 and measured over any 250 consecutive Tx UIs.
  3. A  $T_{TX-EYE} = 0.75$  UI provides for a total sum of deterministic and random jitter budget of  $T_{TX-MAX-JITTER} = 0.25$  UI for the Transmitter collected over any 250 consecutive Tx UIs. The  $T_{TX-EYE-MEDIAN-to-MAX-JITTER}$  median is less than half of the total Tx jitter budget collected over any 250 consecutive Tx UIs. It should be noted that the median is not the same as the mean. The jitter median describes the point in time where the number of jitter points on either side is approximately equal as opposed to the averaged time value.
  4. The DSP device SerDes transmitter does not have a built-in  $C_{TX}$ . An external AC coupling capacitor is required.

**Table 36. PCI Express 2.0 (5.0 Gbps) Differential Receiver (Rx) Input AC Specifications**

At recommended operating conditions (see Table 4).

Parameter	Symbol	Min	Nom	Max	Units	Conditions
Unit Interval	UI	199.40	200.00	200.06	ps	Each UI is 400 ps $\pm$ 300 ppm. UI does not account for spread spectrum clock dictated variations. See Note 1.
Max Rx inherent timing error	$T_{RX-TJ-CC}$	—	—	0.4	UI	The maximum inherent total timing error for common REF_CLK Rx architecture
Maximum time between the jitter median and maximum deviation from the median	$T_{RX-TJ-DC}$	—	—	0.34	UI	Max Rx inherent total timing error
Max Rx inherent deterministic timing error	$T_{RX-DJ-DD-CC}$	—	—	0.30	UI	The maximum inherent deterministic timing error for common REF_CLK Rx architecture
Max Rx inherent deterministic timing error	$T_{RX-DJ-DD-DC}$	—	—	0.24	UI	The maximum inherent deterministic timing error for common REF_CLK Rx architecture

**Note:** No test load is necessarily associated with this value.

The AC timing and voltage parameters must be verified at the measurement point. The package pins of the device must be connected to the test/measurement load within 0.2 inches of that load, as shown in Figure 15.

## NOTE

The allowance of the measurement point to be within 0.2 inches of the package pins is meant to acknowledge that package/board routing may benefit from D+ and D– not being exactly matched in length at the package pin boundary. If the vendor does not explicitly state where the measurement point is located, the measurement point is assumed to be the D+ and D– package pins.

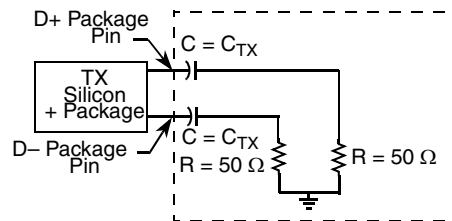

Figure 15. Test Measurement Load

### 3.6.2.4 Serial RapidIO AC Timing Specifications

Table 37 defines the transmitter AC specifications for the Serial RapidIO interface at frequencies up to 3.125 Gbaud. The AC timing specifications do not include REF\_CLK jitter.

**Table 37. Serial RapidIO Transmitter AC Timing Specifications Up to 3.125 Gbaud**

At recommended operating conditions (see Table 4).

Characteristic	Symbol	Min	Nom	Max	Unit
Deterministic Jitter	$J_D$	—	—	0.17	UI p-p
Total Jitter	$J_T$	—	—	0.35	UI p-p
Unit Interval: 1.25 GBaud	UI	800 – 100ppm	800	800 + 100ppm	ps
Unit Interval: 2.5 GBaud	UI	400 – 100ppm	400	400 + 100ppm	ps
Unit Interval: 3.125 GBaud	UI	320 – 100ppm	320	320 + 100ppm	ps

Table 38 defines the Receiver AC specifications for the Serial RapidIO interface at frequencies up to 3.125 Gbaud. The AC timing specifications do not include REF\_CLK jitter.

**Table 38. Serial RapidIO Receiver AC Timing Specifications Up to 3.125 Gbaud**

At recommended operating conditions (see Table 4).

Characteristic	Symbol	Min	Nom	Max	Unit	Notes
Deterministic Jitter Tolerance	$J_D$	—	—	0.37	UI p-p	1
Combined Deterministic and Random Jitter Tolerance	$J_{DR}$	—	—	0.55	UI p-p	1
Total Jitter Tolerance	$J_T$	—	—	0.65	UI p-p	1, 2
Bit Error Rate	BER	—	—	$10^{-12}$	—	—

## Electrical Characteristics

**Table 38. Serial RapidIO Receiver AC Timing Specifications Up to 3.125 Gbaud (continued)**

At recommended operating conditions (see [Table 4](#)).

Characteristic	Symbol	Min	Nom	Max	Unit	Notes
Unit Interval: 1.25 GBaud	UI	800 – 100ppm	800	800 + 100ppm	ps	—
Unit Interval: 2.5 GBaud	UI	400 – 100ppm	400	400 + 100ppm	ps	—
Unit Interval: 3.125 GBaud	UI	320 – 100ppm	320	320 + 100ppm	ps	—

- Notes:**
1. Measured at receiver.
  2. Total jitter is composed of three components, deterministic jitter, random jitter and single frequency sinusoidal jitter. The sinusoidal jitter may have any amplitude and frequency in the unshaded region of [Figure 16](#). The sinusoidal jitter component is included to ensure margin for low frequency jitter, wander, noise, crosstalk and other variable system effects.

[Table 39](#) defines the short run transmitter AC specifications for the Serial RapidIO interface at 5 Gbaud. The AC timing specifications do not include REF\_CLK jitter.

**Table 39. Serial RapidIO Short Run Transmitter AC Timing Specifications at 5.0 Gbaud**

At recommended operating conditions (see [Table 4](#)).

Characteristic	Symbol	Min	Nom	Max	Unit
Uncorrelated High Probability Jitter	T_UHPJ	—	—	0.15	UI p-p
Total Jitter	T_TJ	—	—	0.30	UI p-p
Baud Rate	UI	5.000 – 100ppm	5.000	5.000 + 100ppm	Gbaud

[Table 40](#) defines the short run Receiver AC specifications for the Serial RapidIO interface at 5 Gbaud. The AC timing specifications do not include REF\_CLK jitter.

**Table 40. Serial RapidIO Short Run Receiver AC Timing Specifications at 5 Gbaud**

At recommended operating conditions (see [Table 4](#)).

Characteristic	Symbol	Min	Nom	Max	Unit
Rx Baud Rate	R_Baud	5.000 – 100ppm	5.000	5.000 + 100ppm	Gbaud
Uncorrelated Bounded High Probability Jitter	R_UBHPJ	—	—	0.15	UIp-p
Correlated Bounded High Probability Jitter	R_CBHPJ	—	—	0.3	UIp-p
Bounded High Probability Jitter	R_BHPJ	—	—	0.45	UIp-p
Sinusoidal Jitter maximum	R_SJ-max	—	—	5	UIp-p
Sinusoidal Jitter, High Frequency	R_SJ-hf	—	—	0.05	UIp-p
Total jitter (without sinusoidal jitter)	R_Tj	—	—	0.6	UIp-p

- Note:** The AC specifications do not include REF\_CLK jitter. The sinusoidal jitter may have any amplitude and frequency in the unshaded region in [Figure 17](#). The ISI jitter (R\_CBHPJ) and amplitude have to be correlated, for example, by a PCB trace.



Table 41 defines the Transmitter AC specifications for long run Serial RapidIO interfaces using a transfer rate of 5 Gbps. The AC timing specifications do not include REF\_CLK jitter.

**Table 41. Serial RapidIO Transmitter Long Run AC Timing for Transfer Rate of 5 Gbps**

At recommended operating conditions (see Table 4).

Characteristic	Symbol	Min	Nom	Max	Unit	Conditions
Tx Baud Rate	T_Baud	5.000 – 100 ppm	5.000	5.000 + 100 ppm	Gbps	± 100 ppm
Uncorrelated high probability jitter	T_UHPJ	—	—	0.15	UI p-p	With de-emphasis disabled.
Total Jitter	T_TJ	—	—	0.30	UI p-p	With de-emphasis disabled.

Table 42 defines the Receiver AC specifications for long run Serial RapidIO interfaces using a transfer rate of 5 Gbps. The AC timing specifications do not include REF\_CLK jitter.

**Table 42. Serial RapidIO Receiver Long Run AC Timing for Transfer Rate of 5 Gbps**

At recommended operating conditions (see Table 4).

Characteristic	Symbol	Min	Nom	Max	Unit	Condition
Rx Baud Rate	R_Baud	5.000 – 100 ppm	5.000	5.000 + 100 ppm	Gbps	—
Gaussian	R_GJ	—	—	0.275	UI p-p	Informative jitter budget @Rx input
Uncorrelated bounded high probability jitter ( $D_J$ )	R_UBHPJ	—	—	0.15	UI p-p	Informative jitter budget @Rx input
Correlated bounded high probability jitter (ISI)	R_CBHPJ	—	—	0.525	UI p-p	Informative jitter budget @Rx input
Bounded high probability jitter ( $D_J$ + ISI)	R_BHPJ	—	—	0.675	UI p-p	Informative jitter budget @Rx input
Sinusoidal jitter, maximum	R_SJ-max	—	—	5	UI p-p	Informative jitter budget @Rx input
Sinusoidal jitter, high frequency	R_SJ-hf	—	—	0.05	UI p-p	Informative jitter budget @Rx input
Total Jitter (does not include sinusoidal jitter).	R_TJ	—	—	0.95	UI p-p	Informative jitter budget @Rx input

**Note:** The AC specifications do not include REF\_CLK jitter. The sinusoidal jitter in the total jitter tolerance may have any amplitude and frequency in the unshaded region of Figure 17. The ISI jitter (R\_CBHPJ) and amplitude have to be correlated, for example, by a PC trace.

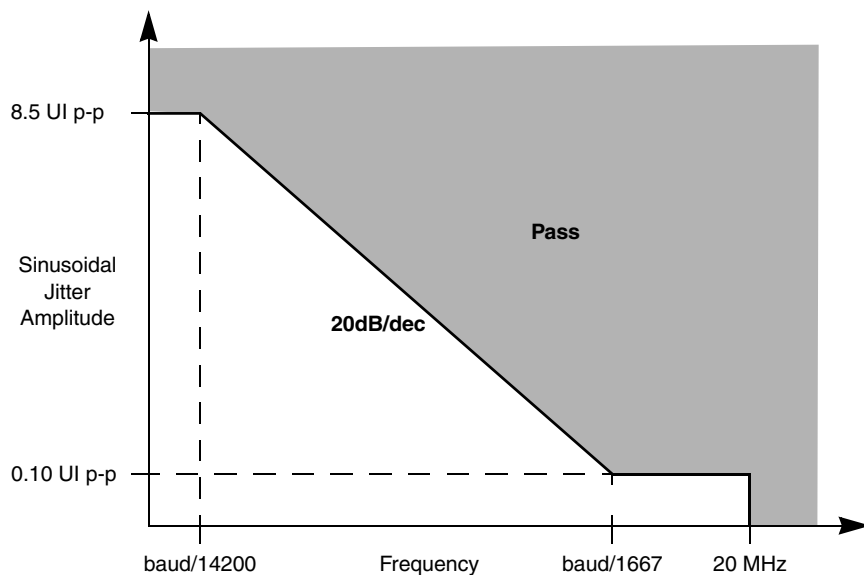

Figure 16. Single Frequency Sinusoidal Jitter Limits for Data Rates for 3.125 Gbps and below

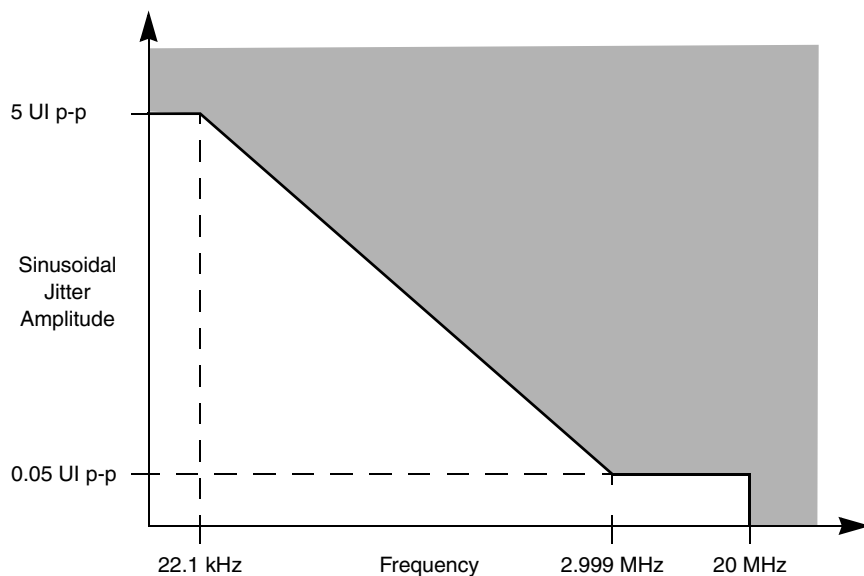

Figure 17. Single Frequency Sinusoidal Jitter Limits for Data Rate 5.0 Gbps

### 3.6.2.5 CPRI AC Timing Specifications

Table 43 defines the transmitter AC specifications for the CPRI LV lanes. The AC timing specifications do not include REF\_CLK jitter.

**Table 43. CPRI Transmitter AC Timing Specifications (LV-I: 1.2288, 2.4576, and 3.072 Gbps)**

At recommended operating conditions (see Table 4).

Characteristic	Symbol	Min	Nom	Max	Unit
Deterministic Jitter	JD	—	—	0.17	UI p-p
Total Jitter	JT	—	—	0.35	UI p-p
Unit Interval: 1.2288 GBaud	UI	1/1228.8 – 100ppm	1/1228.8	1/1228.8 + 100ppm	μs
Unit Interval: 2.4576 GBaud	UI	1/2457.6 – 100ppm	1/2457.6	1/2457.6 + 100ppm	μs
Unit Interval: 3.072 GBaud	UI	1/3072.0 – 100ppm	1/3072.0	1/3072.0 + 100ppm	μs

Table 44 defines the transmitter AC specifications for the CPRI LV-II lanes. The AC timing specifications do not include REF\_CLK jitter.

**Table 44. CPRI Transmitter AC Timing Specifications (LV-II: 1.2288, 2.4576, 3.072, 4.9152, and 6.144 Gbps)**

At recommended operating conditions (see Table 4).

Characteristic	Symbol	Min	Nom	Max	Unit
Uncorrelated High Probability Jitter	T_UHPJ	—	—	0.15	UI p-p
Total Jitter	T_TJ	—	—	0.30	UI p-p
Unit Interval: 1.2288 GBaud	UI	1/1228.8 – 100ppm	1/1228.8	1/1228.8 + 100ppm	μs
Unit Interval: 2.4576 GBaud	UI	1/2457.6 – 100ppm	1/2457.6	1/2457.6 + 100ppm	μs
Unit Interval: 3.072 GBaud	UI	1/3072.0 – 100ppm	1/3072.0	1/3072.0 + 100ppm	μs
Unit Interval: 4.9152 GBaud	UI	1/4915.2 – 100ppm	1/4915.2.8	1/4915.2 + 100ppm	μs
Unit Interval: 6.144 GBaud	UI	1/6144.0 – 100ppm	1/6144.0	1/6144.0 + 100ppm	μs

Table 45 defines the receiver AC specifications for CPRI LV. The AC timing specifications do not include REF\_CLK jitter.

**Table 45. CPRI Receiver AC Timing Specifications (LV-I: 1.2288, 2.4576, and 3.072 Gbps)**

At recommended operating conditions (see Table 4).

Characteristic	Symbol	Min	Nom	Max	Unit
Deterministic jitter tolerance	JD	—	—	0.37	UI p-p
Combined deterministic and random jitter tolerance	JDR	—	—	0.55	UI p-p
Total Jitter tolerance	JT	—	—	0.65	UI p-p

## Electrical Characteristics

**Table 45. CPRI Receiver AC Timing Specifications (LV-I: 1.2288, 2.4576, and 3.072 Gbps) (continued)**

At recommended operating conditions (see Table 4).

Characteristic	Symbol	Min	Nom	Max	Unit
Unit Interval: 1.2288 GBaud	UI	1/1228.8 – 100ppm	1/1228.8	1/1228.8 + 100ppm	ps
Unit Interval: 2.4576 GBaud	UI	1/2457.6 – 100ppm	1/2457.6	1/2457.6 + 100ppm	ps
Unit Interval: 3.072 GBaud	UI	1/3072.0 – 100ppm	1/3072.0	1/3072.0 + 100ppm	ps
Bit error ratio	BER	—	—	10 <sup>-12</sup>	—

Table 46 defines the receiver AC specifications for CPRI LV-II. The AC timing specifications do not include REF\_CLK jitter.

**Table 46. CPRI Receiver AC Timing Specifications (LV-II: 1.2288, 2.4576, 3.072, 4.9152, and 6.144 Gbps)**

At recommended operating conditions (see Table 4).

Characteristic	Symbol	Min	Nom	Max	Unit
Gaussian	R_GJ	—	—	0.275	UI p-p
Uncorrelated bounded high probability jitter	R_UBHPJ	—	—	0.150	UI p-p
Correlated bounded high probability jitter	R_CBHPJ	—	—	0.525	UI p-p
Bounded high probability jitter	R_BHPJ	—	—	0.675	UI p-p
Sinusoidal jitter, maximum	R_SJ-max	—	—	5.000	UI p-p
Sinusoidal jitter, high frequency	R_SJ-hf	—	—	0.050	UI p-p
Total Jitter (does not include sinusoidal jitter).	R_TJ	—	—	0.950	UI p-p
Unit Interval: 1.2288 GBaud	UI	1/1228.8 – 100ppm	1/1228.8	1/1228.8 + 100ppm	μs
Unit Interval: 2.4576 GBaud	UI	1/2457.6 – 100ppm	1/2457.6	1/2457.6 + 100ppm	μs
Unit Interval: 3.072 GBaud	UI	1/3072.0 – 100ppm	1/3072.0	1/3072.0 + 100ppm	μs
Unit Interval: 4.9152 GBaud	UI	1/4915.2 – 100ppm	1/4915.2.8	1/4915.2 + 100ppm	μs
Unit Interval: 6.144 GBaud	UI	1/6144.0 – 100ppm	1/6144.0	1/6144.0 + 100ppm	μs

**Note:** The AC specifications do not include REF\_CLK jitter. The sinusoidal jitter in the total jitter tolerance may have any amplitude and frequency in the unshaded region of Figure 17. The ISI jitter (R\_CBHPJ) and amplitude have to be correlated, for example, by a PC trace.

### NOTE

The intended application is a point-to-point interface up to two connectors. The maximum allowed total loss (channel + interconnects + other loss) is 20.4 dB @ 6.144 Gbps.

### 3.6.2.6 SGMII AC Timing Specifications

Transmitter and receiver AC characteristics are measured at the transmitter outputs ( $\overline{SD}_{[A-J]}_{TX}$  and  $\overline{SD}_{[A-J]}_{TX}$ ) or at the receiver inputs ( $\overline{SD}_{[A-J]}_{RX}$  and  $\overline{SD}_{[A-J]}_{RX}$ ) as depicted in Figure 18, respectively.

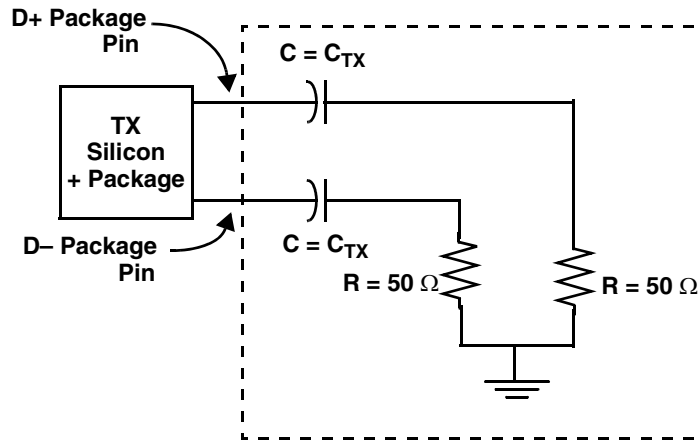

Figure 18. SGMII AC Test/Masurement Load

Table 47 provides the SGMII transmit AC timing specifications. The AC timing specifications do not include REF\_CLK jitter.

Table 47. SGMII Transmit AC Timing Specifications

At recommended operating conditions (see Table 4).

Parameter	Symbol	Min	Nom	Max	Unit	Condition
Unit interval	UI	800 – 100ppm	800	800 + 100ppm	pS	± 100ppm
Deterministic jitter	JD	—	—	0.17	UI p-p	—
Total jitter	JT	—	—	0.35	UI p-p	—
AC coupling capacitor	CTX	75	—	200	nF	All transmitters must be AC-coupled

**Note:** The AC specifications do not include REF\_CLK jitter.

Table 48 provides the SGMII receiver AC timing specifications. The AC timing specifications do not include REF\_CLK jitter.

Table 48. SGMII Receive AC Timing Specifications

At recommended operating conditions (see Table 4).

Parameter	Symbol	Min	Nom	Max	Unit	Condition
Unit interval	UI	800 – 100ppm	800	800 + 100ppm	pS	± 100ppm
Deterministic jitter tolerance	JD	—	—	0.37	UI p-p	Measured at receiver.
Combined deterministic and random jitter tolerance	JDR	—	—	0.55	UI p-p	Measured at receiver
Total jitter tolerance	JT	—	—	0.65	UI p-p	Measured at receiver
Bit error ratio	BER	—	—	$10^{-12}$	—	—

**Note:** The AC specifications do not include REF\_CLK jitter. The sinusoidal jitter in the total jitter tolerance may have any amplitude and frequency in the unshaded region shown in Figure 19 or Figure 20.

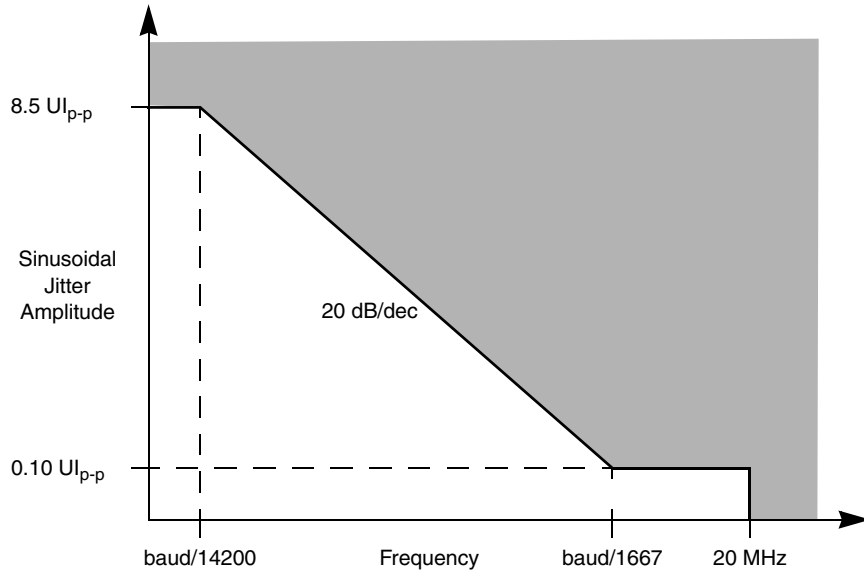

Figure 19. Single Frequency Sinusoidal Jitter Limits for Baud Rate for <3.125 Gbps

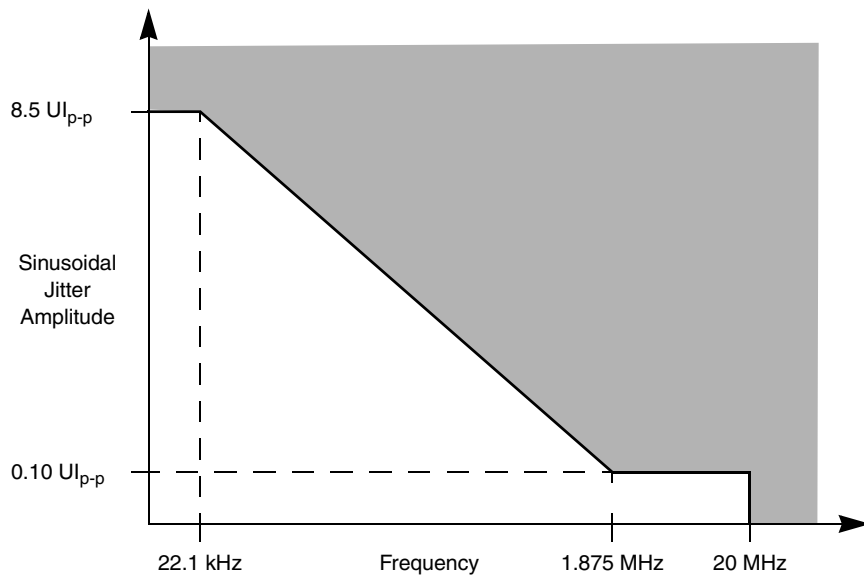

Figure 20. Single Frequency Sinusoidal Jitter Limits for Baud Rate for 3.125 Gbps

### 3.6.3 Timers and Timers\_32b AC Timing Specifications

Table 49 lists the timer input AC timing specifications.

**Table 49. Timers Input AC Timing Specifications**

At recommended operating conditions (see Table 4).

Characteristics	Symbol	Minimum	Unit	Notes
Timers inputs—minimum pulse width	$T_{TIWID}$	8	ns	1, 2

- Notes:**
1. The maximum allowed frequency of timer outputs is 125 MHz. Configure the timer modules appropriately.
  2. Timer inputs and outputs are asynchronous to any visible clock. Timer outputs should be synchronized before use by any external synchronous logic. Timer inputs are required to be valid for at least  $t_{TIWID}$  ns to ensure proper operation.

Figure 21 shows the AC test load for the timers

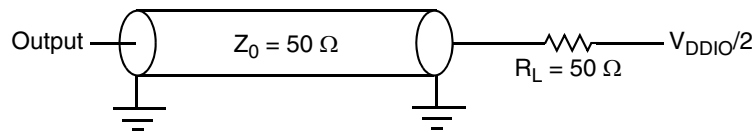

**Figure 21. Timer AC Test Load**

### 3.6.4 Ethernet Timing

This section describes the AC electrical characteristics for the Ethernet interface.

There are three general configuration registers used to configure the timing: GCR4, UCC1\_DELAY\_HR, and UCC3\_DELAY\_HR. These registers configure the programmable delay units (PDU) that should be programmed differently for each Interface to meet timing requirements. For additional information, see the *MSC8157 Reference Manual*.

#### 3.6.4.1 Management Interface Timing

**Table 50. Ethernet Controller Management Interface Timing**

Characteristics	Symbol	Min	Max	Unit
GE_MDC frequency	$f_{MDC}$	—	2.5	MHz
GE_MDC period	$t_{MDC}$	400	—	ns
GE_MDC clock pulse width high	$t_{MDC\_H}$	160	—	ns
GE_MDC clock pulse width low	$t_{MDC\_L}$	160	—	ns
GE_MDC to GE_MDIO delay	$t_{MDKHDX}$	10	70	ns
GE_MDIO to GE_MDC rising edge setup time	$t_{MDDVKH}$	20	—	ns
GE_MDC rising edge to GE_MDIO hold time	$t_{MDDXKH}$	0	—	ns

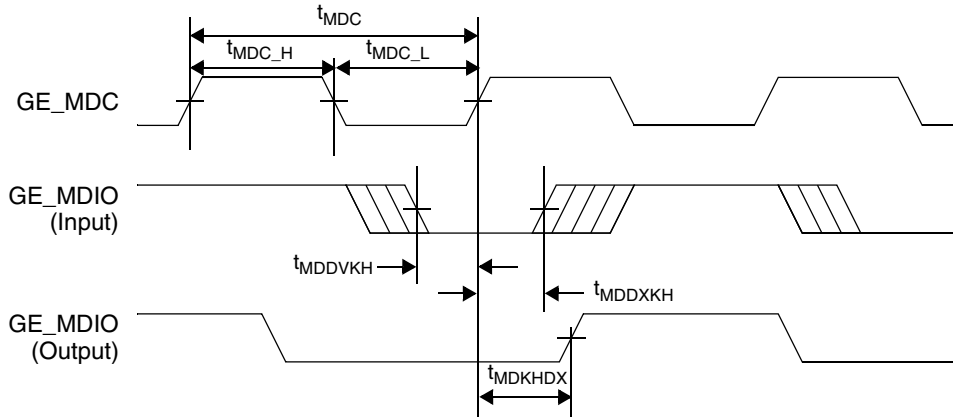

Figure 22. MII Management Interface Timing

### 3.6.4.2 RGMII AC Timing Specifications

Table 51 presents the RGMII AC timing specifications for applications requiring an on-board delayed clock.

Table 51. RGMII at 1 Gbps with On-Board Delay<sup>2</sup> AC Timing Specifications<sup>1</sup>

Parameter/Condition	Symbol	Min	Typ	Max	Unit
Data to clock output skew (at transmitter) <sup>3</sup>	$t_{SKEWT}$	-0.5	—	0.5	ns
Data to clock input skew (at receiver) <sup>3</sup>	$t_{SKEWR}$	1	—	2.6	ns

- Notes:**
1. At recommended operating conditions with  $V_{DDIO}$  of 2.5 V  $\pm$  5%.
  2. Program GCR4 as 0x00000000, UCC1\_DELAY\_HR as 0x00000000, and UCC3\_DELAY\_HR as 0x00000000.
  3. This implies that PC board design requires clocks to be routed such that an additional trace delay of greater than 1.5 ns and less than 2.0 ns is added to the associated clock signal.

Figure 23 shows the RGMII AC timing and multiplexing diagrams.

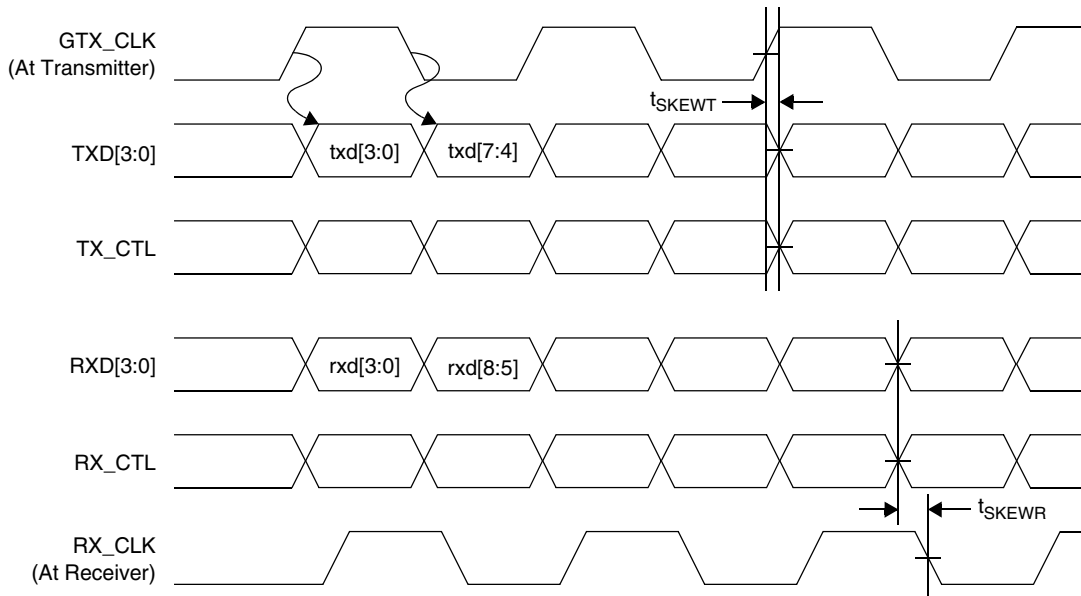

Figure 23. RGMII AC Timing and Multiplexing



### 3.6.5 SPI Timing

Table 52 lists the SPI input and output AC timing specifications.

**Table 52. SPI AC Timing Specifications**

Parameter	Symbol <sup>1</sup>	Min	Max	Unit	Note
SPI outputs valid—Master mode (internal clock) delay	$t_{\text{NIKHOV}}$	—	7	ns	2
SPI outputs hold—Master mode (internal clock) delay	$t_{\text{NIKHOX}}$	0.5	—	ns	2
SPI outputs valid—Slave mode (external clock) delay	$t_{\text{NEKHOV}}$	—	13	ns	2
SPI outputs hold—Slave mode (external clock) delay	$t_{\text{NEKHOX}}$	2	—	ns	2
SPI inputs—Master mode (internal clock) input setup time	$t_{\text{NIIVKH}}$	13	—	ns	—
SPI inputs—Master mode (internal clock) input hold time	$t_{\text{NIIXKH}}$	0	—	ns	—
SPI inputs—Slave mode (external clock) input setup time	$t_{\text{NEIVKH}}$	4	—	ns	—
SPI inputs—Slave mode (external clock) input hold time	$t_{\text{NEIXKH}}$	2	—	ns	—

- Notes:**
- The symbols used for timing specifications follow the pattern of  $t_{\text{(first two letters of functional block)(reference)(state)(signal)(state)}}$  for inputs and  $t_{\text{(first two letters of functional block)(reference)(state)(signal)(state)}}$  for outputs. For example,  $t_{\text{NIKHOX}}$  symbolizes the internal timing (NI) for the time SPICLK clock reference (K) goes to the high state (H) until outputs (O) are invalid (X).
  - Output specifications are measured from the 50% level of the rising edge of SPICLK to the 50% level of the signal. Timings are measured at the pin.

Figure 24 provides the AC test load for the SPI.

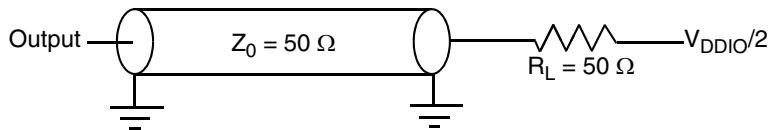

**Figure 24. SPI AC Test Load**

Figure 25 and Figure 26 represent the AC timings from Table 52. Note that although the specifications generally reference the rising edge of the clock, these AC timing diagrams also apply when the falling edge is the active edge.

Figure 25 shows the SPI timings in slave mode (external clock).

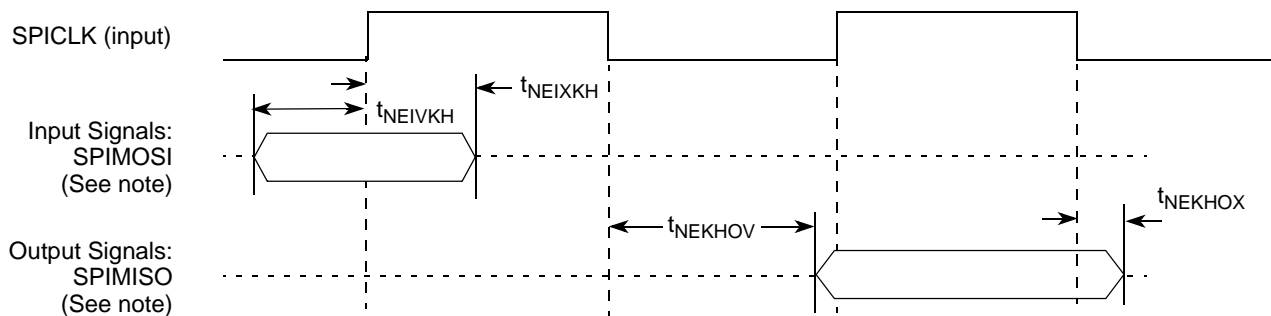

**Note:** measured with  $\text{SPMODE}[\text{CI}] = 0$ ,  $\text{SPMODE}[\text{CP}] = 0$

**Figure 25. SPI AC Timing in Slave Mode (External Clock)**

## Electrical Characteristics

Figure 26 shows the SPI timings in master mode (internal clock).

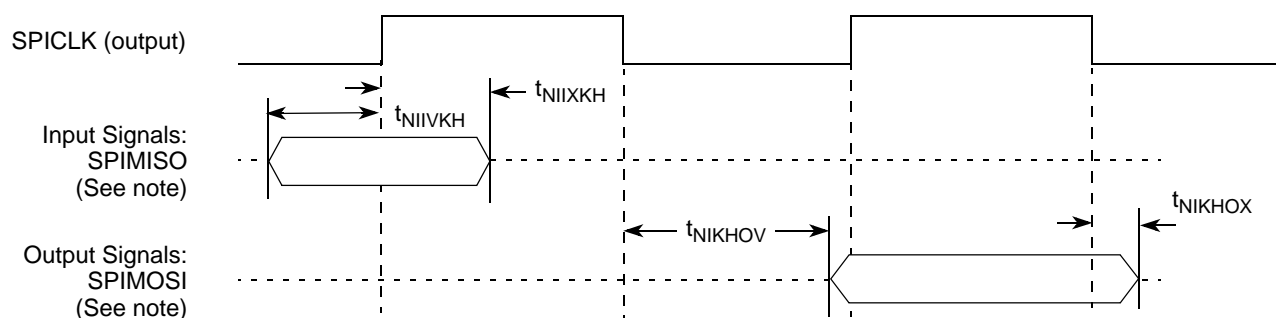

**Note:** measured with SPMODE[CI] = 0, SPMODE[CP] = 0

**Figure 26. SPI AC Timing in Master Mode (Internal Clock)**

### 3.6.6 Asynchronous Signal Timing

Table 53 lists the asynchronous signal timing specifications.

**Table 53. Signal Timing**

Characteristics	Symbol	Type	Min
Input	$t_{IN}$	Asynchronous	One CLKIN/MCLKIN cycle
Output	$t_{OUT}$	Asynchronous	Application dependent

**Note:** Input value relevant for EE0,  $\overline{IRQ}[15-0]$ , and  $\overline{NMI}$  only.

The following interfaces use the specified asynchronous signals:

- *GPIO*. Signals GPIO[31–0], when used as GPIO signals, that is, when the alternate multiplexed special functions are not selected.

#### NOTE

When used as a general purpose input (GPI), the input signal should be driven until it is acknowledged by the MSC8157 device, that is, when the expected input value is read from the GPIO data register.

- *EE port*. Signals EE0, EE1.
- *Boot function*. Signal STOP\_BS.
- *I<sup>2</sup>C interface*. Signals I2C\_SCL and I2C\_SDA.
- *Interrupt inputs*. Signals  $\overline{IRQ}[15-0]$  and  $\overline{NMI}$ .
- *Interrupt outputs*. Signals  $\overline{INT\_OUT/CP\_TX\_INT}$  and  $\overline{NMI\_OUT/CP\_RX\_INT}$  (minimum pulse width is 32 ns).

### 3.6.7 JTAG Signals

**Table 54. JTAG Timing**

Characteristics	Symbol	All Frequencies		Unit
		Min	Max	
TCK cycle time	$t_{TCKX}$	36.0	—	ns
TCK clock high phase measured at $V_M = V_{DDIO}/2$	$t_{TCKH}$	15.0	—	ns
Boundary scan input data setup time	$t_{BSVKH}$	0.0	—	ns
Boundary scan input data hold time	$t_{BSXKH}$	15.0	—	ns
TCK fall to output data valid	$t_{TCKHOV}$	—	20.0	ns
TCK fall to output high impedance	$t_{TCKHOZ}$	—	24.0	ns
TMS, TDI data setup time	$t_{TDIVKH}$	5.0	—	ns
TMS, TDI data hold time	$t_{TDIXKH}$	5.0	—	ns
TCK fall to TDO data valid	$t_{TDOHOV}$	—	10.0	ns
TCK fall to TDO high impedance	$t_{TDOHOZ}$	—	12.0	ns
$\overline{TRST}$ assert time	$t_{TRST}$	100.0	—	ns

**Note:** All timings apply to OnCE module data transfers as well as any other transfers via the JTAG port.

Figure 27 shows the test clock input timing diagram.

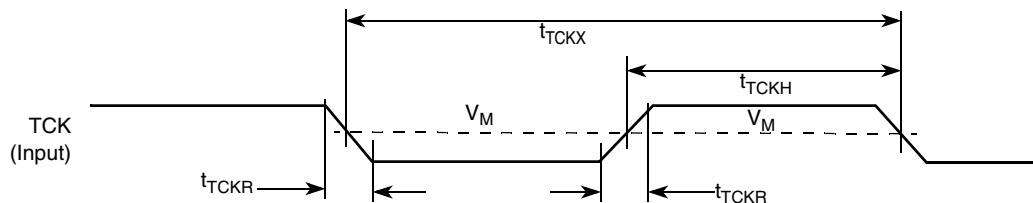
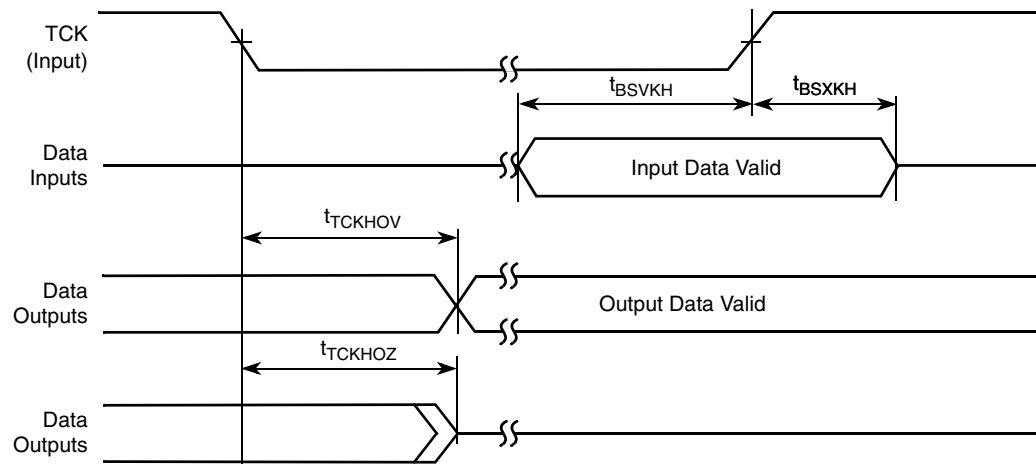

**Figure 27. Test Clock Input Timing**

Figure 28 shows the boundary scan (JTAG) timing diagram.

**Figure 28. Boundary Scan (JTAG) Timing**

## Hardware Design Considerations

Figure 29 shows the test access port timing diagram

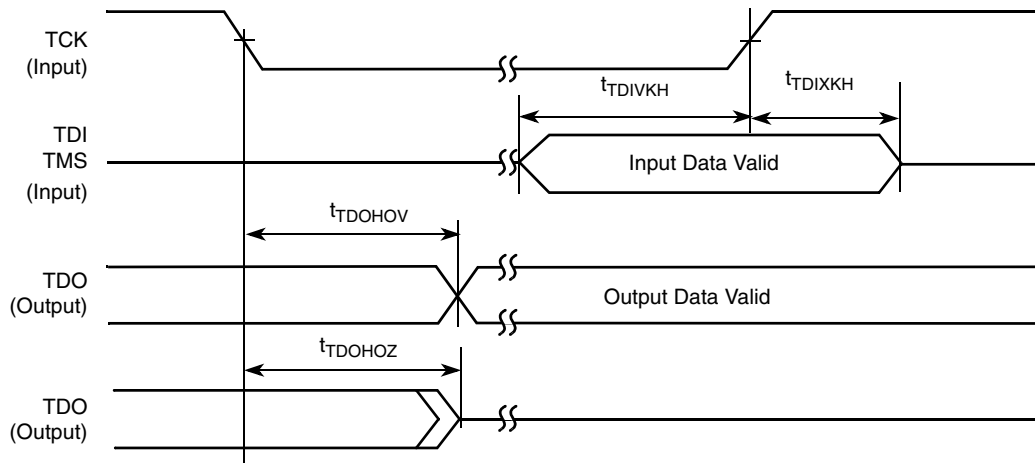

Figure 29. Test Access Port Timing

Figure 30 shows the  $\overline{\text{TRST}}$  timing diagram.



Figure 30.  $\overline{\text{TRST}}$  Timing

## 4 Hardware Design Considerations

For detailed information about how to design this device into an application, see the *MSC8157 Design Checklist* (AN4110).

## 5 Ordering Information

Consult a Freescale Semiconductor sales office or authorized distributor to determine product availability and place an order.

Table 55. Orderable Part Numbers

Qual status	Part	Operating Temp	Package Type	Core Frequency (MHz)	Die revision
PC = Prototype  MSC = Production	8157	S = 0° C to 105°C T = -40° to 105°C	VT = FC-PBGA C5 lead-free AG = FC-PBGA C4/C5 lead-free	1000 = 1 GHz	A = Rev 1.1

# 6 Package Information

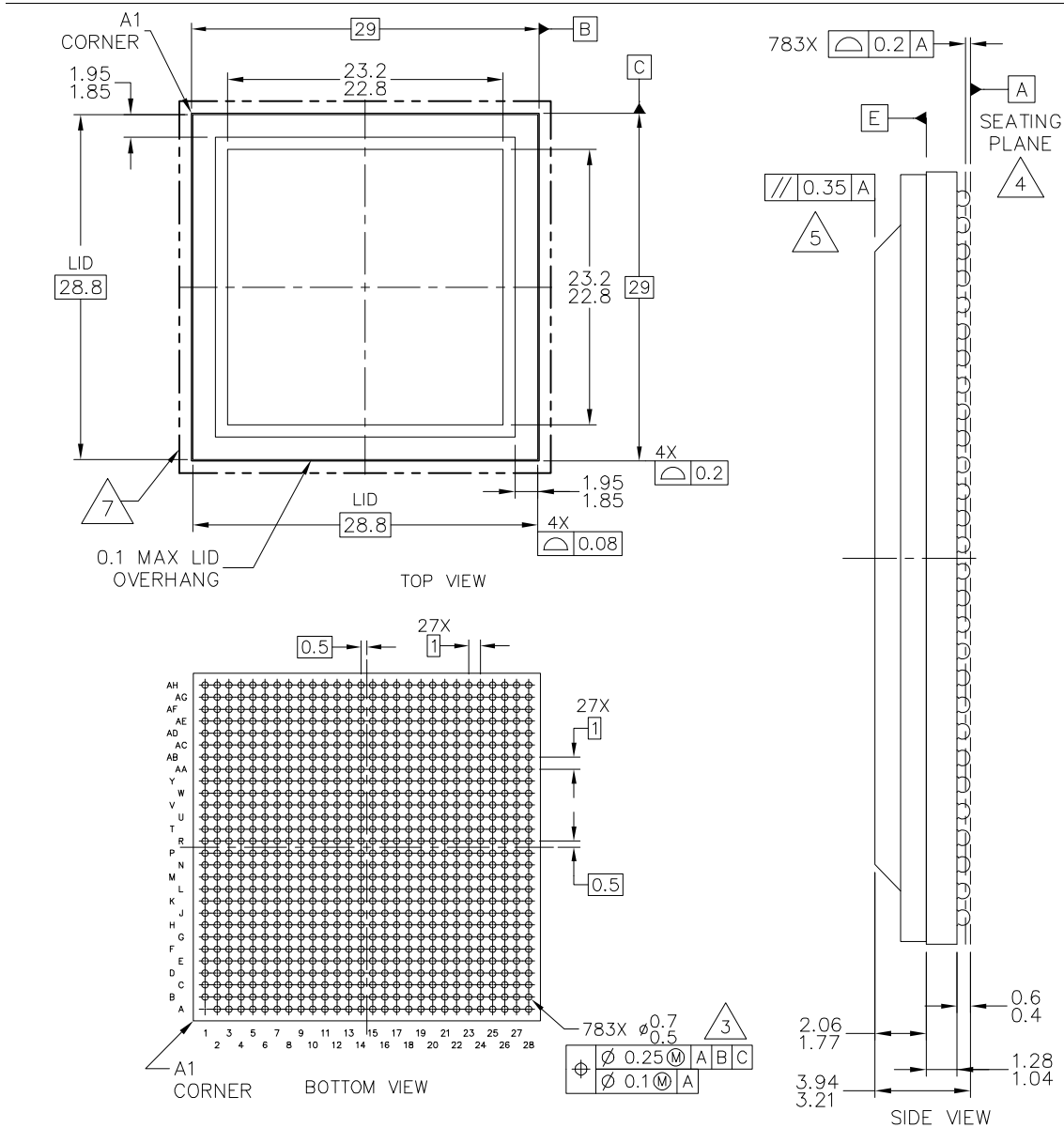

**Figure 31. MSC8157 Mechanical Information, 783-ball FC-PBGA Package**

**NOTES:**

1. All dimensions in millimeters.
2. Dimensioning and tolerancing per ASME Y14.5M-1994.
3. Maximum solder ball diameter measure parallel to Datum A.
4. Datum A, the seating plane, is determined by the spherical crowns of the solder balls.
5. Parallelism measurement shall exclude any effect of mark on top surface of package.
6. All dimensions are symmetric across the package center lines, unless dimensioned otherwise.
7. 29.2mm maximum package assembly (lid + laminate) X and Y.

## 7 Product Documentation

The following is a general list of supporting documentation:

- *MSC8157 Technical Data Sheet* (MSC8157). Details the signals, AC/DC characteristics, clock signal characteristics, package and pinout, and electrical design considerations of the MSC8157 device.
- *MSC8157 Reference Manual* (MSC8157RM). Includes functional descriptions of the extended cores and all the internal subsystems including configuration and programming information.
- *Application Notes*. Cover various programming topics related to the StarCore DSP core and the MSC8157 device.
- *QUICC Engine Block Reference Manual with Protocol Interworking* (QEIWRM). Provides detailed information regarding the QUICC Engine technology including functional description, registers, and programming information.

## 8 Revision History

Table 56 provides a revision history for this data sheet.

**Table 56. Document Revision History**

Revision	Date	Description
3	12/2103	Updated Table 55, "Orderable Part Numbers."
2	10/2013	Updated Table 55, "Orderable Part Numbers."
1	12/2012	<ul style="list-style-type: none"> <li>• In Table 52, "SPI AC Timing Specifications," updated <math>t_{\text{NIKH OV}}</math> max value to 7 ns, <math>t_{\text{NEKH OV}}</math> max value to 13 ns, and <math>t_{\text{NII VKH}}</math> min value to 13 ns.</li> <li>• In Table 55, "Orderable Part Numbers," updated the list of supported parts.</li> </ul>
0	11/2011	Initial release of this document.

**How to Reach Us:**

**Home Page:**  
[freescale.com](http://freescale.com)

**Web Support:**  
[freescale.com/support](http://freescale.com/support)

Information in this document is provided solely to enable system and software implementers to use Freescale products. There are no express or implied copyright licenses granted hereunder to design or fabricate any integrated circuits based on the information in this document.

Freescale reserves the right to make changes without further notice to any products herein. Freescale makes no warranty, representation, or guarantee regarding the suitability of its products for any particular purpose, nor does Freescale assume any liability arising out of the application or use of any product or circuit, and specifically disclaims any and all liability, including without limitation consequential or incidental damages. "Typical" parameters that may be provided in Freescale data sheets and/or specifications can and do vary in different applications, and actual performance may vary over time. All operating parameters, including "typicals," must be validated for each customer application by customer's technical experts. Freescale does not convey any license under its patent rights nor the rights of others. Freescale sells products pursuant to standard terms and conditions of sale, which can be found at the following address: [freescale.com/SalesTermsandConditions](http://freescale.com/SalesTermsandConditions).

Freescale, the Freescale logo, and StarCore are trademarks of Freescale Semiconductor, Inc., Reg. U.S. Pat. & Tm. Off. QUICC Engine is a trademark of Freescale Semiconductor, Inc. All other product or service names are the property of their respective owners.

© 2010–2013 Freescale Semiconductor, Inc.