

PART NUMBER	REV	TERMINATOR	FEED TYPE	DESCRIPTION
1529203-1	B	BENCH & LEADMAKER	MECH POST FEED	HDI APPLICATOR
7-1529203-1	B	BENCH & LEADMAKER	MECH POST FEED	-1 AND SPARE PARTS
7-1529203-7	A	-	-	SPARE PARTS KIT

CRIMP DATA	TE TERMINAL	TE CRIMP SPECS
TERMINAL NAME: FASTIN-FASTON 0.250 SERIES REC.		
CRIMP	SIZE	TYPE
WIRE	4.06 [.160 IN]	F
INSUL	5.33 [.210 IN]	F
WIRE STRIP LENGTH		APPL INSTRUCTIONS
4.80-5.60 [.189-.220 IN]		408-8323 & 408-8490
TERMINAL APPL SPEC	114-3118	FEED 21.46 [.845 IN]

TERMINALS APPLIED	WIRE SIZE	CRIMP HEIGHT	REF SETTING
160811	6.00mm ²	2.63 ± 0.05 [.104 ± .002 IN]	B3
-	5.00mm ²	2.44 ± 0.05 [.096 ± .002 IN]	C5
-	2.50mm ² + 2.50mm ²	2.44 ± 0.05 [.096 ± .002 IN]	C5
-	4.00mm ²	2.25 ± 0.05 [.089 ± .002 IN]	E0

- 1 RECOMMENDED SPARE PARTS
- 2. GREASE RAM, CAM, CAM FOLLOWER AND FEED ROD LIGHTLY.
- 3 CERTAIN TERMINALS REQUIRE LUBRICATION. REFER TO THE APPLICATOR INSTRUCTION SHEET FOR MORE INFORMATION.
- 4. LUBRICATE DAILY PER THE APPLICATOR INSTRUCTION SHEET SUPPLIED WITH THE APPLICATOR.
- 5 ITEM 56, CUT TO LENGTH AT ASSEMBLY.
- 6 FOR DOUBLE WIRE COMBINATION 2 X 2.8MM MAX INSULATION DIAMETER APPLIES.

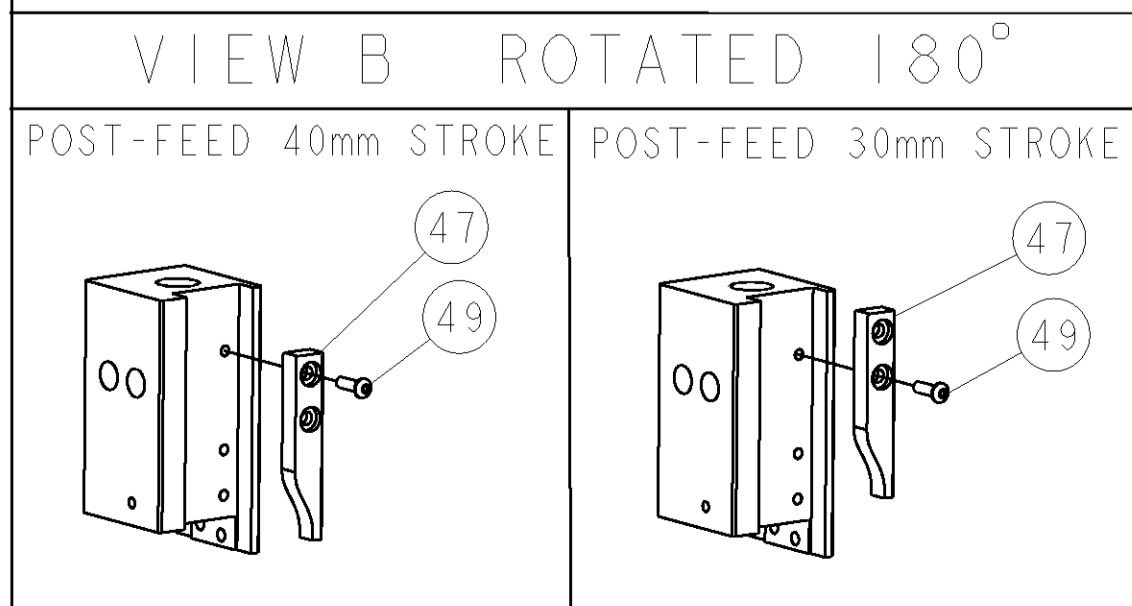

*** WARNING**
 ON INSTALLATION, SET WIRE DISC TO LARGEST WIRE SIZE SETTING. USE OF SETTINGS BELOW MIN. REQUIRED CRIMP HEIGHT SETTING WILL CAUSE DAMAGE TO CRIMP TOOLING.

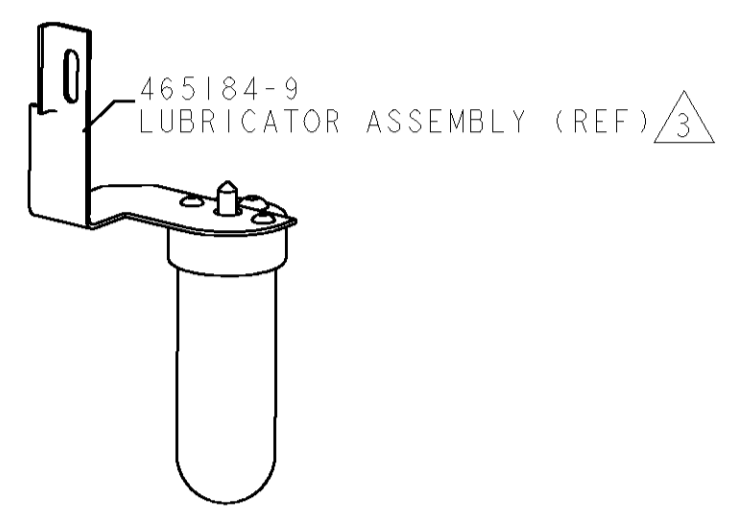
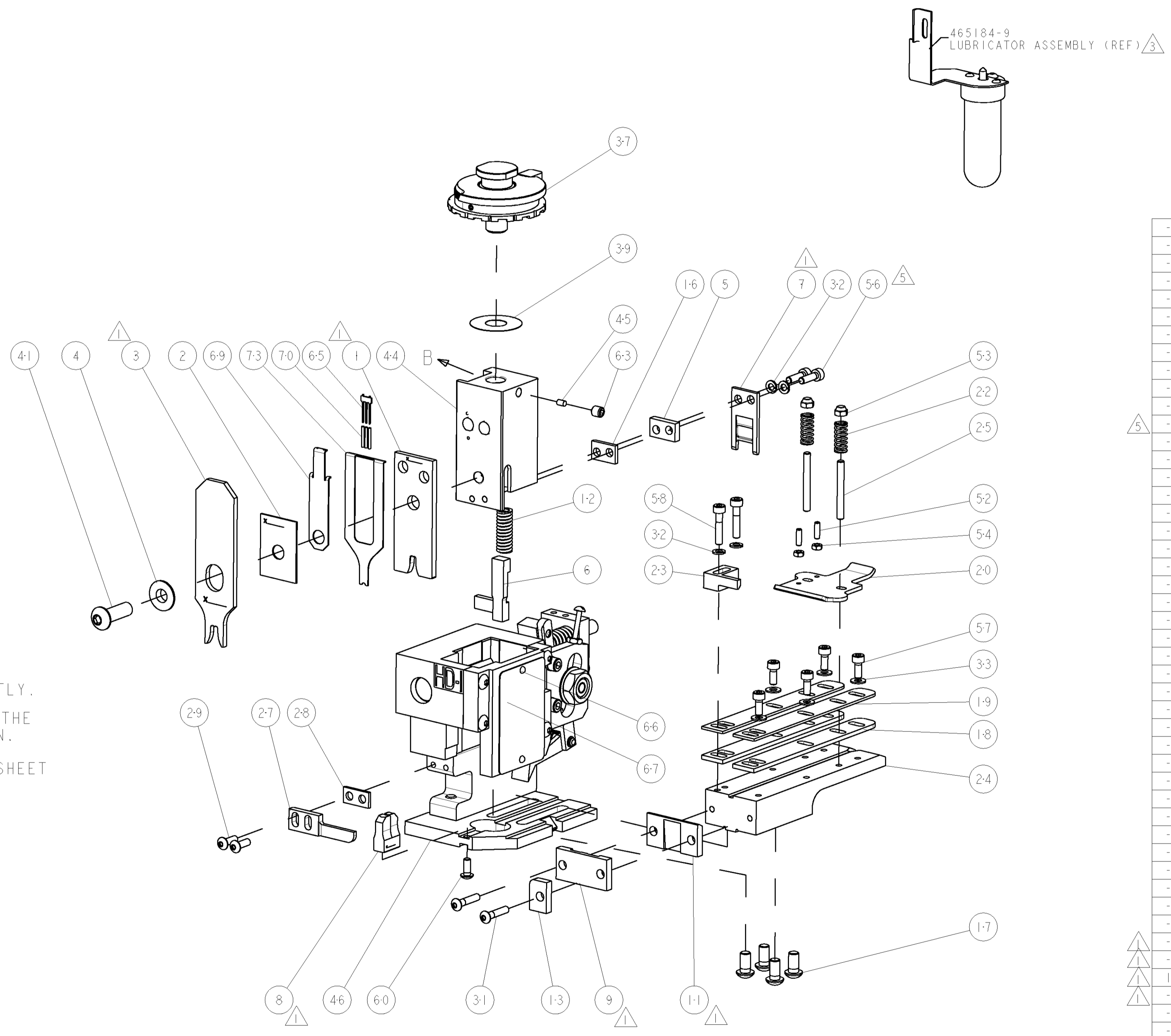

REV	DATE	BY	CHKD	DESCRIPTION
A	02FEB2007	DP	MC	SEE ECO-07-002721
B	16JUN2009	MY	TE	ECR-09-013686

QTY	UNIT	PART NO	DESCRIPTION	ITEM NO
-	1	1490525-3	DEPRESSOR, WIRE	73
-	1	1338705-4	DOCUMENTATION PACKAGE	71
-	3	1-23147-4	SPRING, COMPRESSION	70
-	1	1490524-1	DEPRESSOR, SPACER	69
-	1	461264-5	PLATE, IDENTIFICATION	67
-	2	21017-2	SCREW, DRIVE	66
-	1	1424350-1	HOLDER, PIN, WIRED	65
-	1	3-18031-0	SCR, SET, CUP POINT M6 X 6.0	63
-	1	18024-7	SCR, BTN SKT HD CAP (M4 X 10.0)	60
-	2	1-18023-4	SCR, SKT HD CAP M4 X 20.0	58
-	5	1-18023-1	SCR, SKT HD CAP M4 X 10.0	57
-	2	9-18023-6	SCR, SKT HD CAP M4 X 14.0	56
-	2	18029-1	NUT, HEX, REG M3	54
-	2	986965-1	NUT, LOCK, HEX, TORQUE (M4)	53
-	2	2-18032-2	SCR, SET, FLT POINT M3 X 10.0	52
-	1	18024-3	SCR, BTN SKT HD CAP (M3 X 10.0)	49
-	1	1338676-1	CAM, UNIVERSAL POST-FEED	47
-	1	1338662-2	SUB ASSY, APPLICATOR FRAME	46
-	1	690191-1	PLUG, NYLON	45
-	1	1333260-1	RAM	44
-	1	2-18024-6	SCR, BTN SKT HD CAP (M8 X 25.0)	41
-	1	690125-1	SHIM SUB-ASSY	39
-	1	879103-2	FINE ADJUST HEAD ASSEMBLY	37
-	5	18027-2	WASHER, FLAT, REG M4	33
-	4	18025-2	WASHER, SPRG LOCK, REG M4	32
-	2	1-18024-0	SCR, BTN SKT HD CAP (M4 X 20.0)	31
-	2	18024-8	SCR, BTN SKT HD CAP (M4 X 12.0)	29
-	1	3-690451-2	SPACER, STRIPPER	28
-	1	240639-1	STRIPPER (MACHINING)	27
-	2	1320906-1	STUD, THREADED	25
-	1	1320995-3	PLATE, STRIP GUIDE	24
-	1	240825-3	PLATE, STRIP HOLD DOWN	23
-	2	4-22281-1	SPRING, DRAG	22
-	1	1338665-1	DRAG	20
-	2	1338663-3	GUIDE, LOWER STRIP	19
-	2	1338663-5	GUIDE, LOWER STRIP	18
-	4	1-18024-8	SCR, BTN SKT HD CAP (M6 X 12.0)	17
-	1	1338708-1	SPACER, SLUG BLADE	16
-	1	690481-2	SPACER, HOLD DOWN	13
-	1	23846-1	SPRING, DIE	12
-	1	240833-3	PLATE, REAR SHEAR	11
-	1	690482-3	PLATE, FRONT SHEAR	9
-	1	1333223-2	ANVIL, COMBINATION	8
-	1	2-690474-8	BLADE, SLUG	7
-	1	2-455892-7	HOLD DOWN, TERMINAL	6
-	1	240641-4	SPACER	5
-	1	238009-1	BLOCK, FL CRIMPER SPACER	4
-	1	3-1633471-7	CRIMPER, INSULATION F	3
-	1	455888-7	SPACER, CRIMPER	2
-	1	456427-1	CRIMPER, WIRE	1

DIMENSIONS: INCHES		TOLERANCES UNLESS OTHERWISE SPECIFIED:		DWN 30OCT2006		Tyco Electronics Harrisburg, PA 17105-3608	
9 PLC ±.1		1 PLC ±0.1		APVD 30OCT2006		NAME M. CLIFFORD	
3 PLC ±0.01		4 PLC ±0.001		PRODUCT SPEC		FINE ADJUST END FEED	
MATERIAL		FINISH		WEIGHT		SIZE CAGE CODE DRAWING NO	
						A1 00779 C-1529203	
				CUSTOMER DRAWING		SCALE 3:5 SHEET 1 OF 1 REV B	

CUSTOMER VIEWABLE ASSEMBLY