

CODE No.	CONTACT	A	B	C	D	E
CL537-0528-0-81	20	7.2	4.5	5.3	5.7	5.3
CL537-0530-1-81	30	9.7	7.0	7.8	8.2	7.8
CL537-0531-4-81	36	11.2	8.5	9.3	9.7	9.3
CL537-0532-7-81	40	12.2	9.5	10.3	10.7	10.3
CL537-0534-2-81	50	14.7	12.0	12.8	13.2	12.8
CL537-0536-8-81	60	17.2	14.5	15.3	15.7	15.3

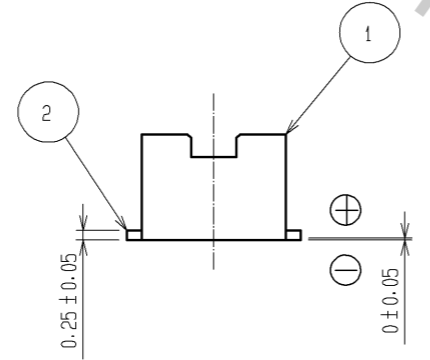

RECOMMEND METAL MASK PATTERN (10:1)

RECOMMENDED LAND PATTERN (10:1)

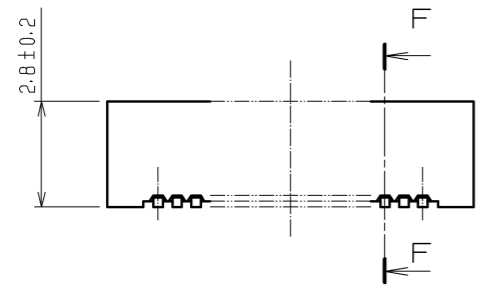
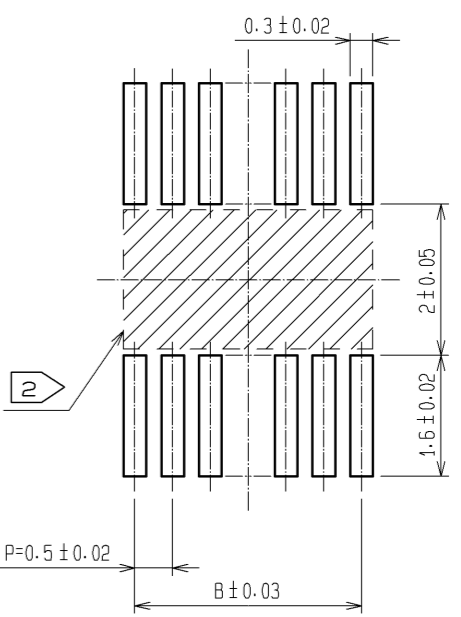
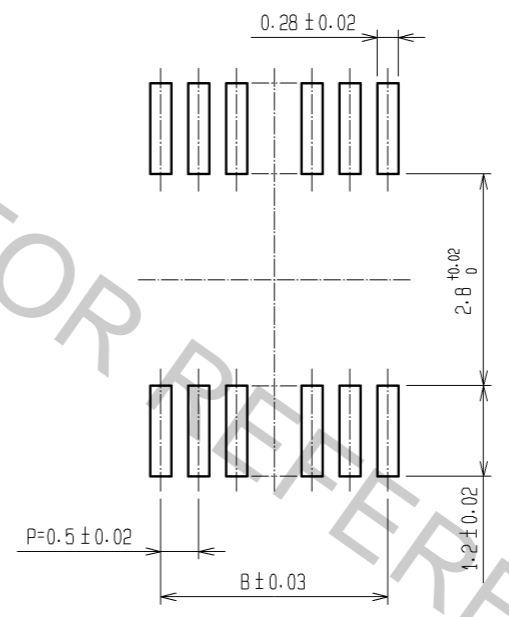

RECOMMENDED THICKNESS OF METAL MASK : 120 μm

RECOMMENDED THICKNESS OF SOLDER PASTE : 120 μm

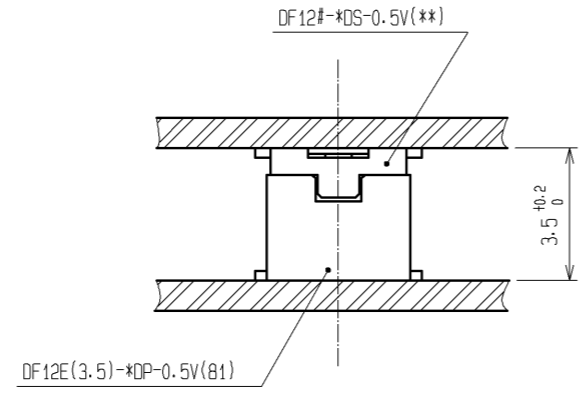
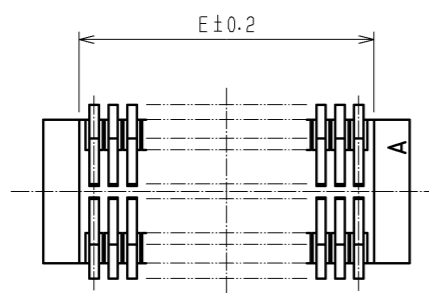

NOTES 1 LEAD CO-PLANARITY SHALL BE 0.08 mm MAX.  
 2 IF THERE IS PATTERN ON [Hatched] PART, THERE IS A POSSIBILITY THAT IT WILL MAKE CONTACT WITH THE LEADS.

2	PHOSPHOR BRONZE	CONTACT AREA:GOLD PLATED 0.2μm min	6	PS	CLEAR (REINFORCEMENT COLLAR)			
		LEAD AREA:GOLD PLATED 0.015μm min	5	PS	BLACK (PLASTIC REEL)			
		OTHERS(UNDER PLATING):NICKEL PLATED 2μm min	4	POLYESTER	CLEAR (COVER TAPE)			
1	POLYAMIDE	UL94V-0.NATURAL(BEIGE)	3	PS	CLEAR (EMBOSSED CARRIER TAPE)			
NO.	MATERIAL	FINISH . REMARKS	NO.	MATERIAL	FINISH . REMARKS			
UNITS mm		SCALE 5 : 1	COUNT 	DESCRIPTION OF REVISIONS		DESIGNED	CHECKED	DATE
<b>HRS</b> HIROSE ELECTRIC CO., LTD.		APPROVED : KH. IKEDA	13.08.19	DRAWING NO. EDC3-163511-77				
		CHECED : YH. MICHIDA	13.08.09	PART NO. DF12E(3.5)-*DP-0.5V(B1)				
		DESIGNED : YN. SAKAMOTO	13.08.08	CODE NO. CL537				
		DRAWN : KR. AJITO	13.08.08					

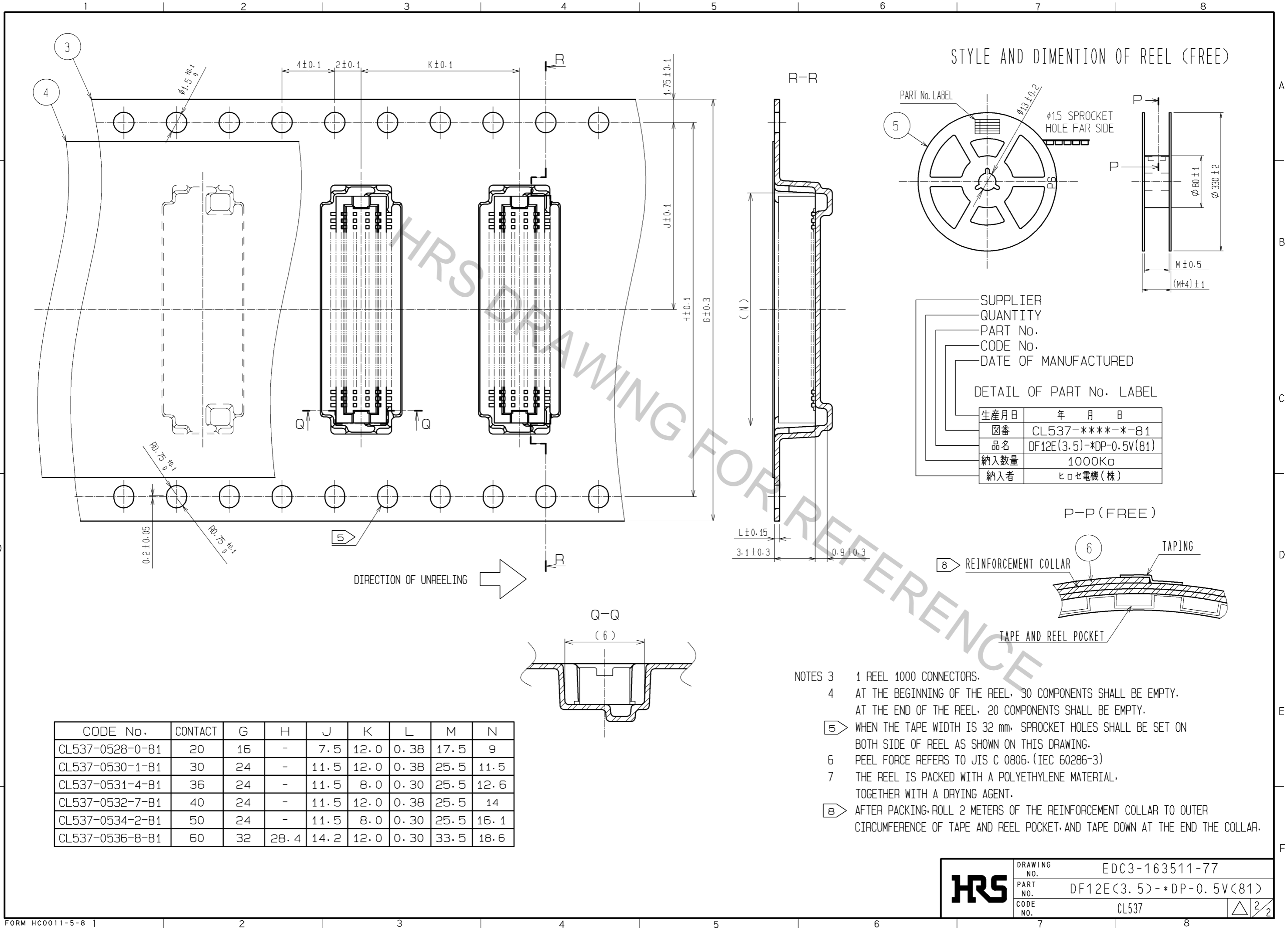

STYLE AND DIMENTION OF REEL (FREE)

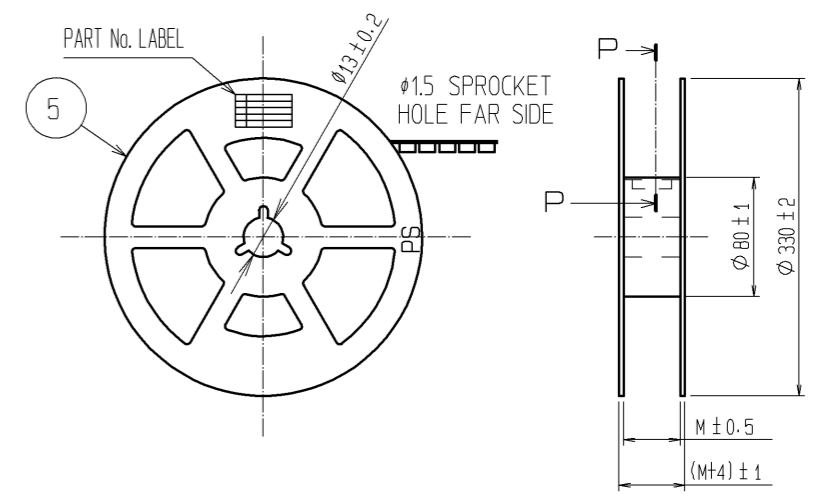

SUPPLIER  
 QUANTITY  
 PART No.  
 CODE No.  
 DATE OF MANUFACTURED

DETAIL OF PART No. LABEL

生産月日	年 月 日
図番	CL537-****-*81
品名	DF12E(3.5)-*DP-0.5V(81)
納入数量	1000Kα
納入者	ヒロセ電機(株)

P-P (FREE)

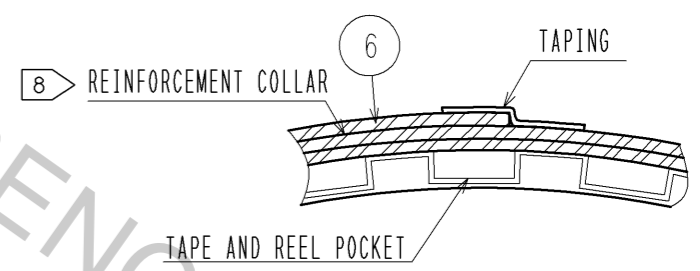

DIRECTION OF UNREELING →

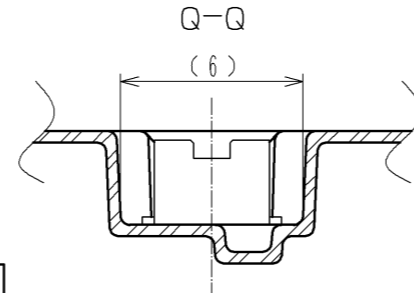

- NOTES 3 1 REEL 1000 CONNECTORS.  
 4 AT THE BEGINNING OF THE REEL, 30 COMPONENTS SHALL BE EMPTY.  
 AT THE END OF THE REEL, 20 COMPONENTS SHALL BE EMPTY.  
 5 WHEN THE TAPE WIDTH IS 32 mm, SPROCKET HOLES SHALL BE SET ON BOTH SIDE OF REEL AS SHOWN ON THIS DRAWING.  
 6 PEEL FORCE REFERS TO JIS C 0806. (IEC 60286-3)  
 7 THE REEL IS PACKED WITH A POLYETHYLENE MATERIAL, TOGETHER WITH A DRYING AGENT.  
 8 AFTER PACKING, ROLL 2 METERS OF THE REINFORCEMENT COLLAR TO OUTER CIRCUMFERENCE OF TAPE AND REEL POCKET, AND TAPE DOWN AT THE END THE COLLAR.

CODE No.	CONTACT	G	H	J	K	L	M	N
CL537-0528-0-81	20	16	-	7.5	12.0	0.38	17.5	9
CL537-0530-1-81	30	24	-	11.5	12.0	0.38	25.5	11.5
CL537-0531-4-81	36	24	-	11.5	8.0	0.30	25.5	12.6
CL537-0532-7-81	40	24	-	11.5	12.0	0.38	25.5	14
CL537-0534-2-81	50	24	-	11.5	8.0	0.30	25.5	16.1
CL537-0536-8-81	60	32	28.4	14.2	12.0	0.30	33.5	18.6

<b>HRS</b>	DRAWING NO.	EDC3-163511-77
	PART NO.	DF12E(3.5)-*DP-0.5V(81)
	CODE NO.	CL537
		△ 2/2