

4

3

2

1

THIS DRAWING IS UNPUBLISHED. RELEASED FOR PUBLICATION ,19 .
 © COPYRIGHT 19 BY AMP INCORPORATED. ALL RIGHTS RESERVED.

LOC	DIST	REVISIONS				
P	LTR	DESCRIPTION	DATE	DWN	APVD	
AF	50	C	REV PER 061A-0184-99	27MAY99	JR SH	

- MATING TAB THK IS 0.51±0.025 [.020±.001].
- CONTINUOUS STRIP ON REELS. TO BE CUT-OFF & BENT IN INSERTION HEAD.

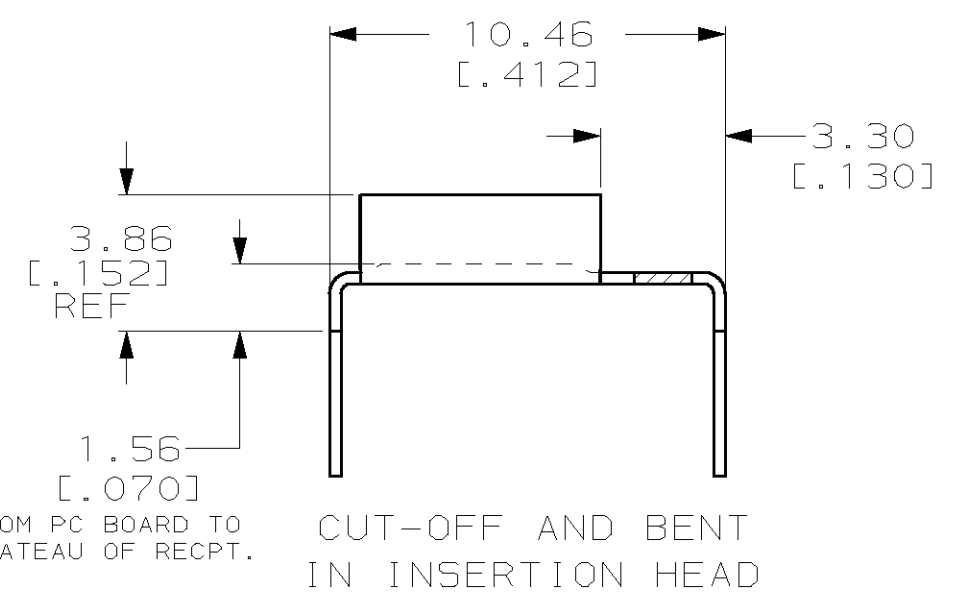
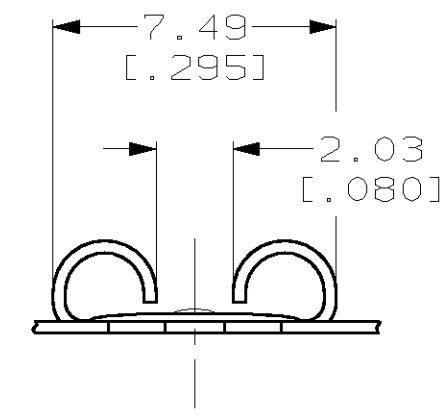
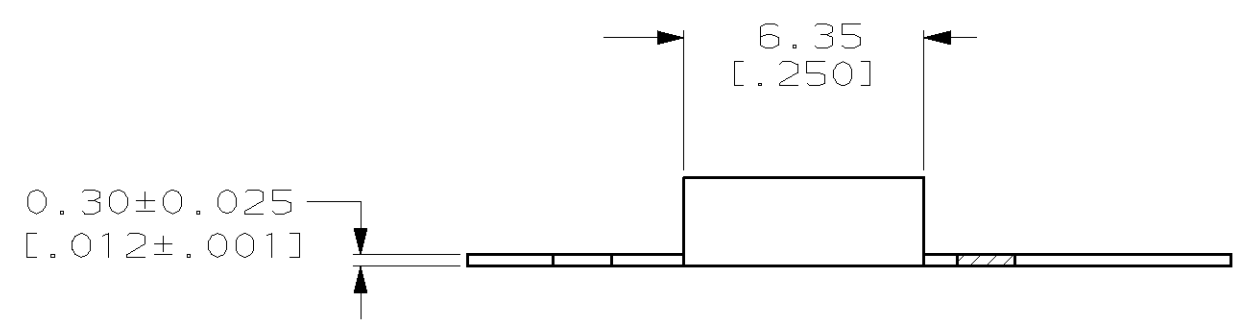
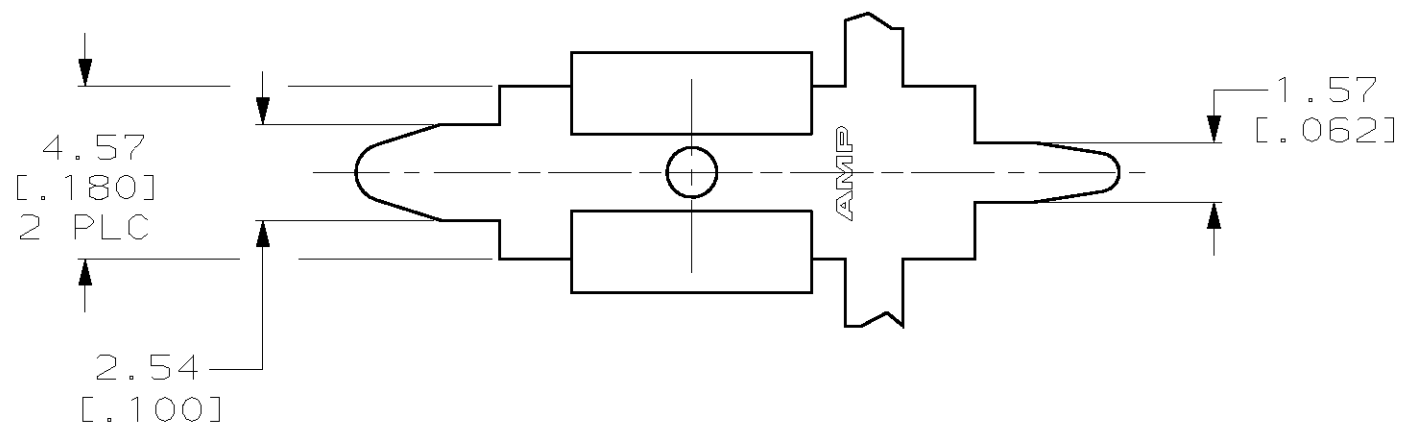

1217107-1
PART NO.

THIS DRAWING IS A CONTROLLED DOCUMENT.		DWN	JR RUTH	11/14/97	AMP AMP Incorporated Harrisburg, PA 17105-3608
DIMENSIONS: MM [INCHES]		CHK	MS FEHER	11/14/97	
TOLERANCES UNLESS OTHERWISE SPECIFIED:		APVD	P DESANTIS	11/14/97	NAME
0 PLC ±-		PRODUCT SPEC		RECEPTACLE, FASTON, 6.35 [.250] SERIES	
1 PLC ±-		APPLICATION SPEC		SIZE	A3
2 PLC ±0.13 [.005]		WEIGHT		CAGE CODE	00779
3 PLC ±-		CUSTOMER DRAWING		DRAWING NO	C- 1217107
4 PLC ±-		SCALE		SHEET	1 OF 1
ANGLES ±-		RESTRICTED TO		REV	C
MATERIAL	T3 PHOS BRONZE	FINISH	0.002032 [.000080] MIN TIN		