

Apr.1.2017 Copyright 2017 HIROSE ELECTRIC CO., LTD. All Rights Reserved.

COUNT	DESCRIPTION OF REVISIONS	BY	CHKD	DATE	COUNT	DESCRIPTION OF REVISIONS	BY	CHKD	DATE

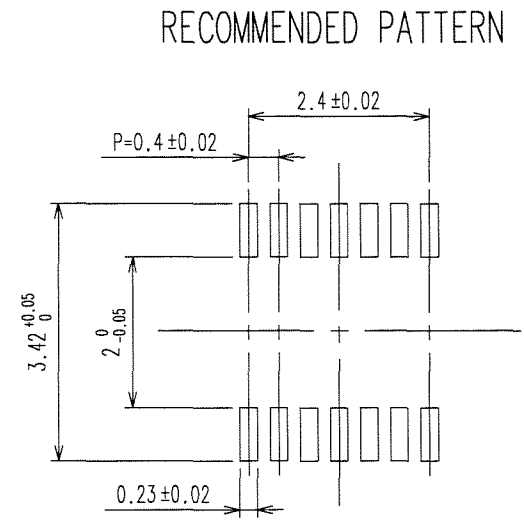

RECOMMENDED METAL MASK
OPENING DIMENSIONS FOR LEAD PAD (20:1)

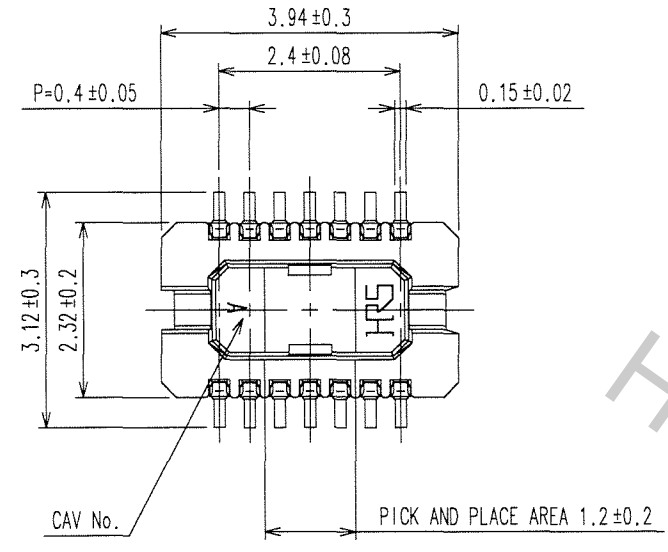
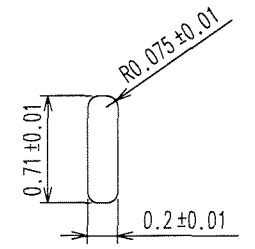

RECOMMENDED SOLDER PASTE THICKNESS : 120μm

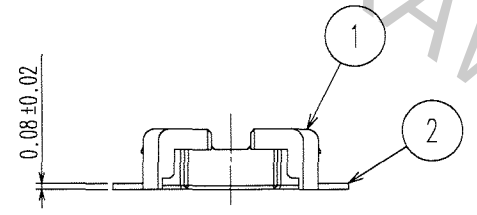
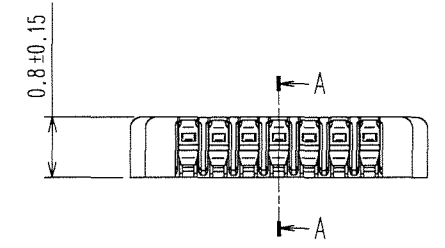

A-A(20:1)

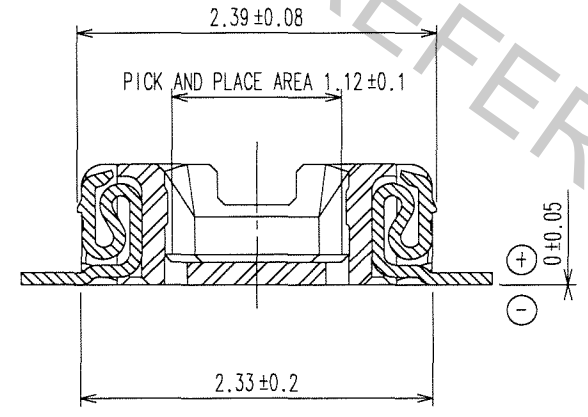

ENGAGEMENT FIGURE(20:1)

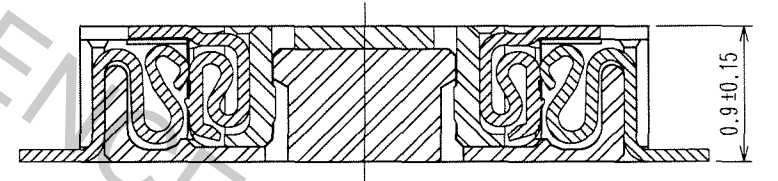

- NOTE 1. ALL LEADS CO-PLANARITY SHALL BE 0.1 MAX.
 2. PER REEL : 5000 CONNECTORS.
 3. AT THE BEGINNING OF THE REEL, 100 MM AT MIN SHALL BE EMPTY POCKETS.
 AT THE END OF THE REEL, 160 MM AT MIN SHALL BE EMPTY POCKETS.
 4. CONTACT PLATING SPECIFICATIONS.
 CONTACT AREA : GOLD 0.05μm MIN.
 SMT LEAD : GOLD 0.02μm MIN.
 UNDERPLATING : NICKEL 1μm MIN.
 (SURFACE : SEALING)

TO

2	PHOSPHOR BRONZE	4	5	PS	PLASTIC REEL(BLACK)	
1	LCP	UL94V-0, BLACK	4	POLYESTER	CLEAR(COVER TAPE)	
			3	PS	CLEAR(EMBOSSD CARRIER TAPE)	
NO.	MATERIAL	FINISH, REMARKS	NO.	MATERIAL	FINISH, REMARKS	
CODE NO. (OLD)		DRAWN	DESIGNED	CHECKED	APPROVED	RELEASED
		T. Yamamoto	T. Yamamoto	T. Miyagaki	M. Nakamura	
		'06.05.20	'06.5.20	'06.05.22	'06.05.22	
DRAWING NO. EDC3-312196-01			PART NO. DF30RC-14DP-0.4V(81)			
SCALE 10 : 1			CODE NO. CL684-1290-0-81			
UNITS mm			HRS HIROSE ELECTRIC CO., LTD			

Apr.1.2017 Copyright 2017 HIROSE ELECTRIC CO., LTD. All Rights Reserved.

COUNT	DESCRIPTION OF REVISIONS	BY	CHKD	DATE	COUNT	DESCRIPTION OF REVISIONS	BY	CHKD	DATE
△					△				
△					△				
△					△				

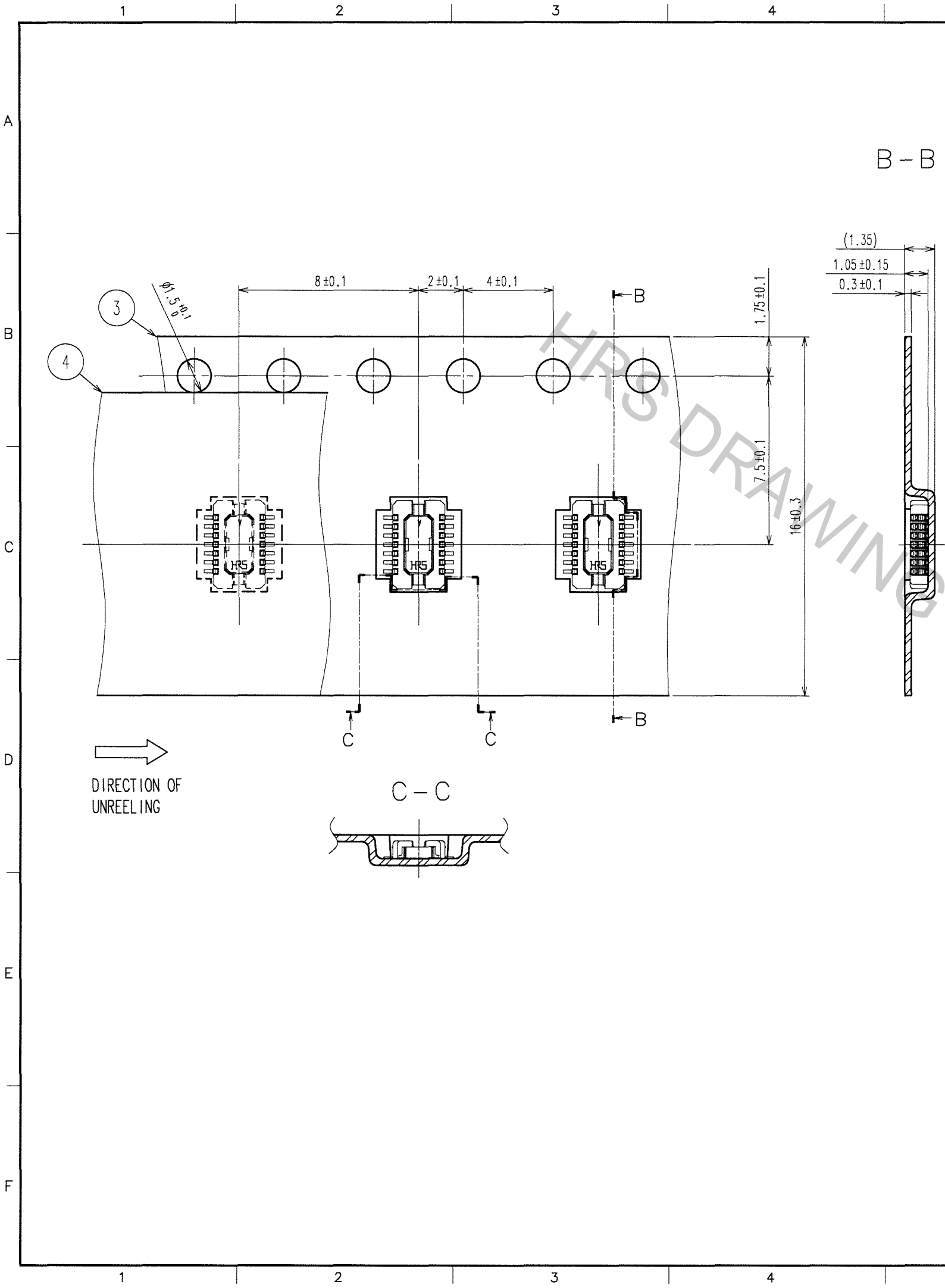

STYLE AND DIMENSION OF REEL (FREE SIZE)

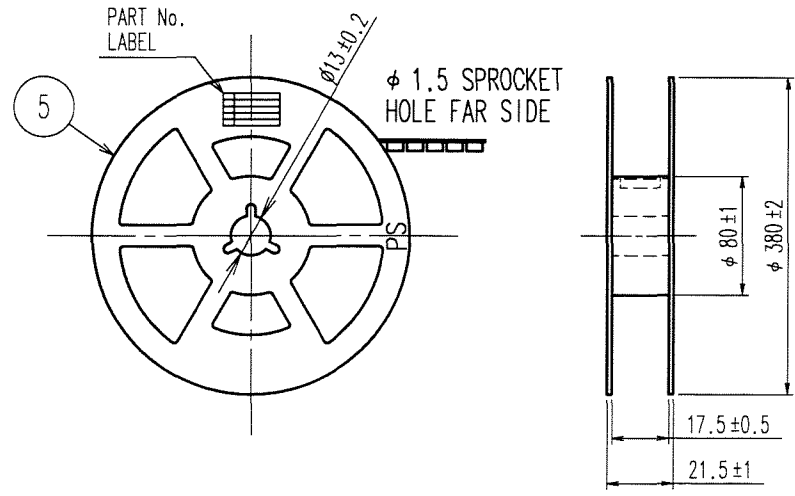

DETAIL OF PART NO. LABEL

SUPPLIER	
QUANTITY	
PART NO.	
CODE NO.	
DATE OF MANUFACTURED	
生産月日	年 月 日
図番	CL684-1290-0-81
品名	DF30RC-14DP-0.4V(81)
納入数量	5000個
納入者	ヒロセ電機(株)

TO

CODE NO. (OLD)	DRAWN T. Yamamoto '06.05.20	DESIGNED T. Yamamoto 06.5.20	CHECKED T. Miyajaki 06.05.22	APPROVED Mr. Nakamura 06.05.22	RELEASED .
DRAWING NO. EDC3-312196-01	PART NO. DF30RC-14DP-0.4V(81)		CODE NO. CL684-1290-0-81		
SCALE 5 : 1	UNITS mm		HRS HIROSE ELECTRIC CO., LTD		