

PRODUCT NUMBER
94561-X1Y
94561-X1YLF

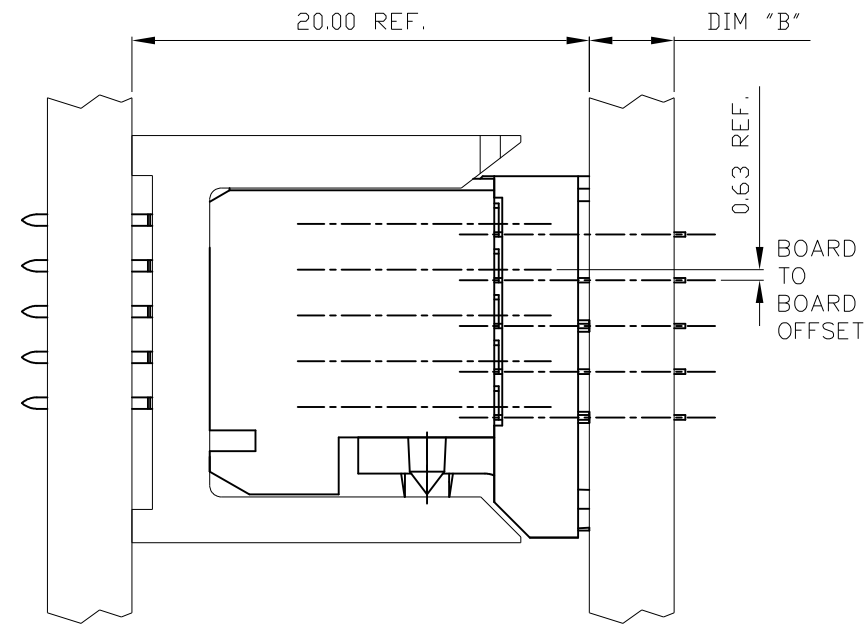
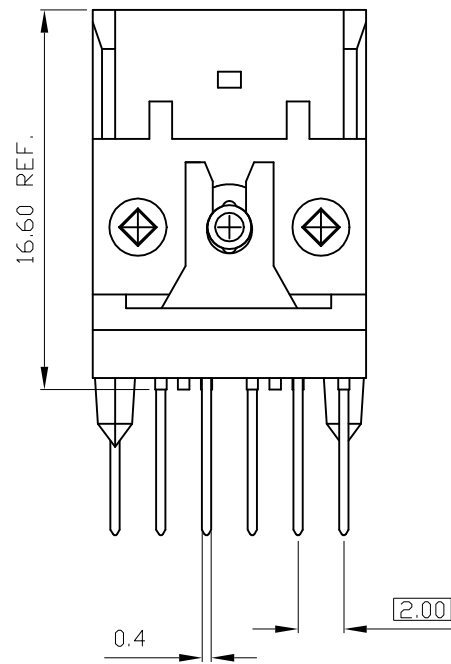
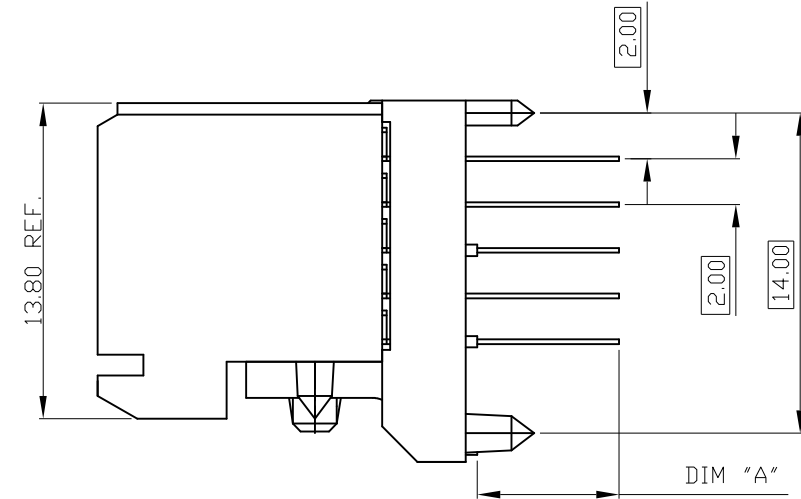
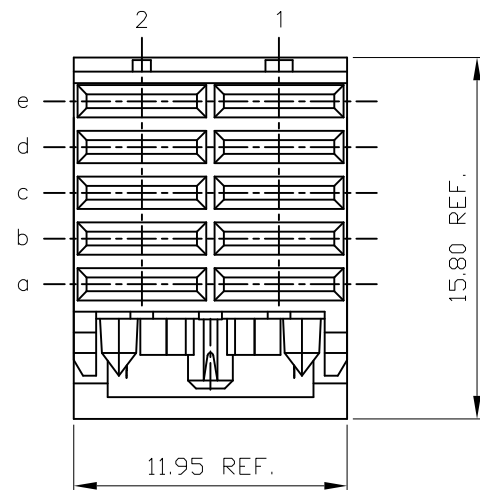

Amphenol FCI

© 2016 AFCI

PRODUCT NR:	PLATING CONTACT AREA:	UNDERPLATING
94561-1YY	0.76 um GOLD	1.3 um Ni MIN.
94561-2YY	2 um GOLD	1.3 um Ni MIN.
94561-9YY	0.76 um GXT	1.3 um Ni MIN.
94561-1YYLF	0.76 um GOLD OR GXT	1.3 um Ni MIN.
94561-2YYLF	2 um GOLD	1.3 um Ni MIN.
94561-9YYLF	0.76 um GXT	1.3 um Ni MIN.

mat'l. code		surface ISO 1302 ✓		tolerance ISO 406 ISO 1101		projection		product family METRAL (tm)	
ltr	ecn no	dr	date	tolerances unless otherwise specified		MM		title	
E	V05-1101	JRV	12/05/05	angles	linear	.X ±.3		VERTICAL POWER	
F	DG08-0171	TER	0903'08	0±2°		.XX ±.10		RECEPT. ASSY. -5 RDW	
G	ELX-N-011386	A.ZH	4/25/12			.XXX ±.050		scale 1:1	
H	ELX-N-26608	MZ	3/22/17	dr	STU STONGER	7/29/96	Amphenol FCI		sheet 1 of 2
				enr	R. DOUTRICH	7/29/96	94561		A3
				chr	STU STONGER	7/29/96	type Product Customer		Drawing
				app	STU STONGER	7/29/96			
sheet index	revision sheet	H	H						
		1	2						

PRODUCT NUMBER	DIM "A" ±0.20	DIM "B" PCB THK.
94561-X11	2.65	1.6
94561-X12	3.45	2.4
94561-X13	4.25	3.2
94561-X11LF	2.65	1.6
94561-X12LF	3.45	2.4
94561-X13LF	4.25	3.2
94561-X14LF	6.50	5.4

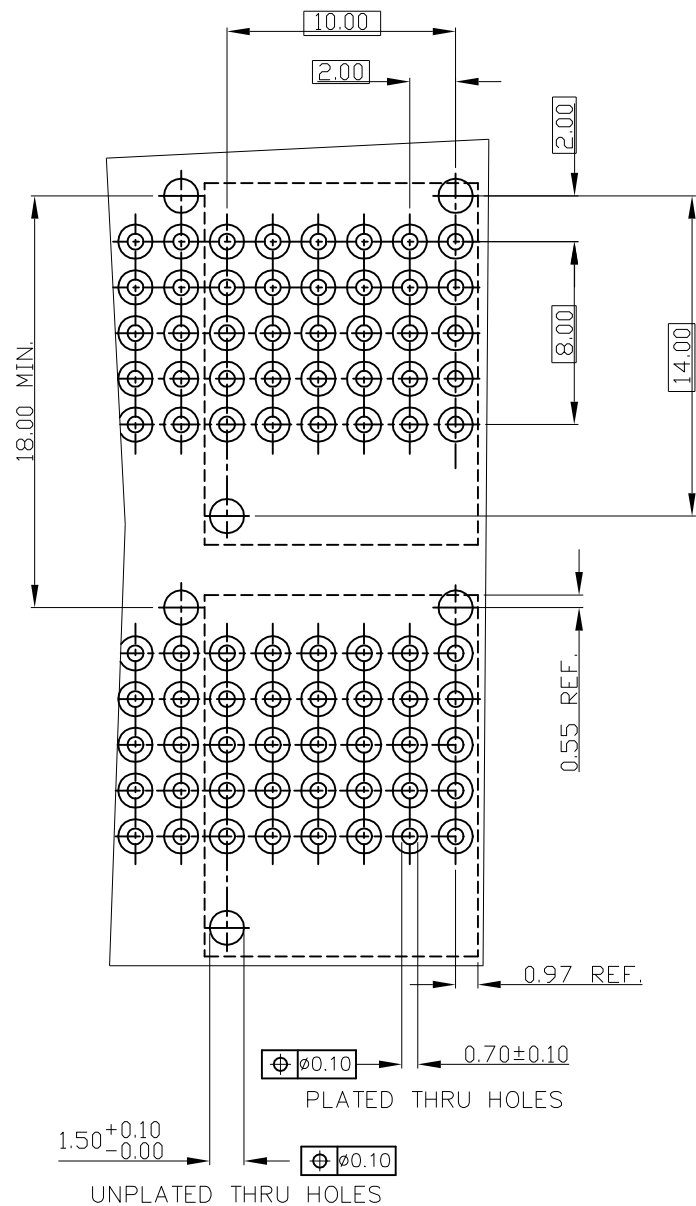

RECOMMENDED HOLE PATTERN
COMPONENT SIDE

NOTES:

- ① CONNECTOR MATERIALS:
HOUSING: LCP, 30% GLASS FILLED,
UL 94-V0 COMPLIANT
TERMINAL: PHOSPHOR BRONZE ALLOY
2. PLATING ON TAIL:
SOLDER-TO-BOARD TYPE
94561-XXX IS 2-8um SnPb
94561-XXYLF IS 2-8um Sn (LEAD FREE)
3. PRODUCT SPECIFICATION:
GS-12-002
4. APPLICATION SPECIFICATIONS:
BUS-20-059
GS-20-001
TA-941
- ⑤ PRODUCT MARKING: (PART NUMBER & LOT CODE).
- ⑥ INDICATED HOLES ARE UNPLATED.
- ⑦ LOCATION PEG FEATURES MAY NOT BE AVAILABLE AS SHOWN FOR ASSYS W/ PRESS PEGS.
- ⑧ TOP SURFACE OF PRESS BLOCK MAY EXTEND UP TO 0.4MM HIGHER THAN HOUSING. THIS MAY AFFECT THE TAIL LENGTH BEFORE APPLICATION TO A BOARD.
- ⑨ DIMENSION APPLIES TO BOTH PRESS-FIT AND SOLDER TAIL TERMINATIONS.
10. THESE PRODUCTS WHERE THE PART NUMBER ENDS IN "LF" MEET AS DESCRIBED IN GS-22-008.

THE EUROPEAN UNION DIRECTIVES AND OTHER COUNTRY REGULATIONS ALL PRODUCTS MANUFACTURED BEFORE APRIL 2006 WILL WITHSTAND EXPOSURE TO 240°C FOR 60 SECONDS IN A CONVECTION, INFAR-RED OR VAPOR PHASE REFLOW OVEN.

ALL PRODUCTS MANUFACTURED AFTER MARCH 2006 WILL WITHSTAND EXPOSURE TO 260°C FOR 60 SECONDS IN A CONVECTION, INFAR-RED OR VAPOR PHASE REFLOW OVEN.
- ⑪ FOR LEAD FREE PART NUMBERS ADD "LF" SUFFIX. EXAMPLE: 94561-XXYLF.

mat'l. code				surface ISO 1302 ✓		tolerance ISO 406 ISO 1101		projection MM		product family METRAL (tm)			
ltr	ecn no	dr	date	tolerances unless otherwise specified						title VERTICAL POWER RECEPT. ASSY. -5 RDW			
H				angles	linear	.X ±.3		MM					
				0±2°		.XX ±.10		scale 1:1					
				dr	J.R. VOLSTORF	12/5/05		Amphenol FCI		dwg no		sheet 2 of 2	size
				enr	J.R. VOLSTORF	12/5/05				94561		A3	
				chr	J.R. VOLSTORF	12/5/05							
				appd	J.R. VOLSTORF	12/5/05							
sheet index	revision sheet												