

DRAWING MADE IN AMERICAN PROJECTION

© 1976 BY AMP INCORPORATED. ALL RIGHTS RESERVED. AMP PRODUCTS COVERED BY PATENTS AND/OR PATENTS PENDING.

THIS DRAWING IS THE PROPERTY OF AMP INCORPORATED. IT IS TO BE USED ONLY FOR THE PURPOSES SPECIFIED HEREON. IT IS NOT TO BE REPRODUCED OR COPIED IN ANY MANNER WITHOUT THE WRITTEN PERMISSION OF AMP INCORPORATED.

Unpublished copy may be reproduced for publication without written permission of AMP Incorporated.

REVISIONS				
ZONE	LTR	DESCRIPTION	DATE	APPROVED
A		IDENT CODE WAS 89110, ECN 8627, DS	2-5-79	M.H.

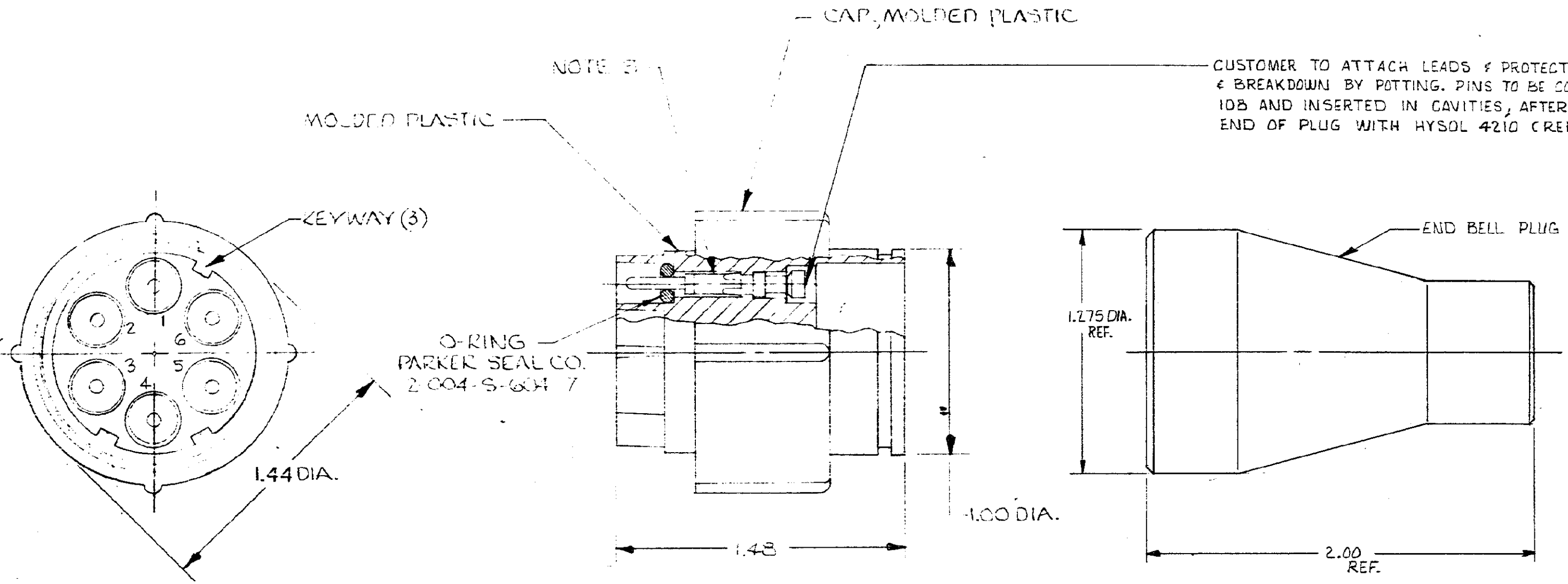

CUSTOMER TO ATTACH LEADS & PROTECT AGAINST ARC-OVER & BREAKDOWN BY POTTING. PINS TO BE COATED WITH RTV 108 AND INSERTED IN CAVITIES, AFTER CURING FILL BACK END OF PLUG WITH HYSOL 4210 (REF. AMP#1-859234-7).

TYPE II PINS TO EXCEPT ONE (1) 14-AWG STRANDED WIRE.

- NOTE:
1. PLUG ASS'Y WILL WITHSTAND WITHOUT BREAKDOWN 27 KVDC PIN TO PIN & 27 KVDC PIN TO GRD. WHEN MATED WITH RECEPTACLE 859527-1.
 2. MARKING TO BE WHITE
 3. *16 GA. PINS GOLD PLATED PER MIL-G-45204 TYPE II .000050 MIN THK.
 4. PLUG & PINS TO BE SHIPPED SEPARATELY.
 5. TYPE II PINS TO EXCEPT ONE (1) *22, *24 OR *20 AWG STRANDED WIRE
 6. TYPE II PINS TO EXCEPT ONE (1) *16 AWG OR (1) 18 AWG STRANDED WIRE
 7. TO REMOVE PINS USE EXTRACTION TOOL *SG1751-1

AMP PART NO.	WIRE SIZE RANGE	HAND TOOL
863023-1	20, 22, 24	45099
863023-2	16, 18	45098
863023-3	14	45098

QTY REQD	QTY REQD	ITEM NO.	DWG SIZE	PART OR IDENTIFYING NO.	NOMENCLATURE OR DESCRIPTION	SYMBOL
-2	-1					

UNLESS OTHERWISE SPECIFIED: DIMENSIONS ARE IN INCHES TOLERANCES .00 = ±.04 ANGLES = J .000 = ±.015				CONTRACT NO. DP DICK STONE 3-1-76 CHK		AMP INCORPORATED CAPITON DIVISION ELIZABETHTOWN, PENNSYLVANIA	
MATERIAL: ~				APPD M. Gardner 3/3/76 APPD		NAME PLUG ASS'Y, H.V. 6 PIN LGH	
FINISH: BLACK				DSGN APPD		SIZE C	CODE IDENT NO. 00779
NEXT ASSY				OTHER APPD		NUMBER 863023	SHEET 1 OF 1
QTY REQD	FINAL ASSY	NEXT ASSY	USED ON	APPLICATION		SCALE	WT