

903-152P-71S7

REVISIONS

DRAWING NO.	REV	DESCRIPTION	DATE	ECO	APPR
THIRD ANGLE PROJ.	A	RELEASE TO MFG.	10/14/98	42675	PB/CPM
	B	SEE SHEET 1	6/24/99	43035	PB/TA
	C	SEE SHEET 1	7/24/99	43084	PB/TA

NOTES:

1. PLATING MUST CONFORM TO AMPHENOL SPEC 349-50560. CONTACT AND BODIES ARE GOLD PLATED, SLEEVE AND FERRULE ARE NICKEL PLATED. (REF)
2. CRIMP USING TOOL 227-944, HEX DIE 227-1221-09 (.178 HEX).
3. DO NOT SCALE THIS DRAWING.

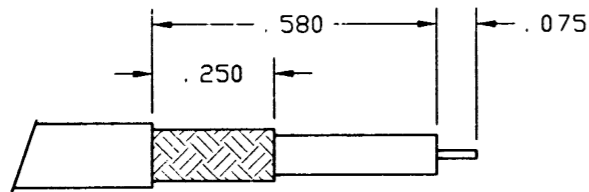
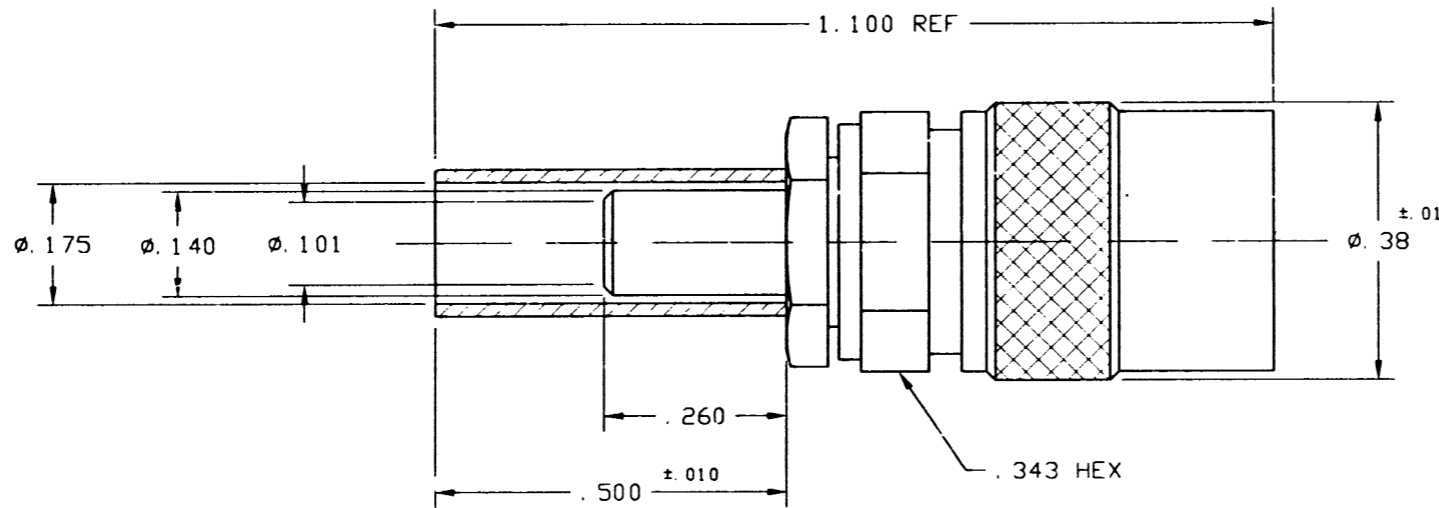

CABLE STRIPPING DIMENSIONS

CUSTOMER DRAWING

UNLESS OTHERWISE SPECIFIED, DIMENSIONS ARE IN INCHES AND TOLERANCES ARE:
 2 PLACE DECIMAL 3 PLACE DECIMAL ANGLES
 ±.015 (0.381 mm) ±.005 (0.127 mm) ± 1°

NOTICE - These drawings, specifications, or other data (1) are, and remain the property of Amphenol Corp. (2) must be returned upon request; and (3) are confidential and not to be disclosed to any person other than those to whom they are given by Amphenol Corp. The furnishing of these drawings, specifications, or other data by Amphenol Corp., or to any other person to anyone for any purpose is not to be regarded by implication or otherwise in any manner licensing, granting rights or permitting such holder or any other person to manufacture, use or sell any product, process or design, patented or otherwise, that may in any way be related to or disclosed by said drawings, specifications, or other data.

MATERIAL

REFERENCE
 EAR 102-967107 0

DRAWN	DATE
P. BRENZEL	8 OCT 98
ENGINEER	DATE
P. BRENZEL	8 OCT 98
APPROVED	DATE
T. AUBIN	10/14/98

TITLE
 SMB 75 OHM PLUG
 LOCKING TYPE
 FOR 735A CABLE

Amphenol
 Amphenol Corporation
 RF/Microwave Operations
 Danbury, Conn. U.S.A. 06810

SCALE: 4:1 SHEET 2 OF 2

CAD FILE
 H: \PETE\SMB\903\ASSY\152P71 7C

CODE ID
 74868

DWG SIZE
 B

DRAWING NO.
 903-152P-71S7

ISSUE
 C