

PART NUMBER	REV	FIRST USED
680820-1	B	122500-1
680820-2	B	565435-5
680820-3	B	354500-1

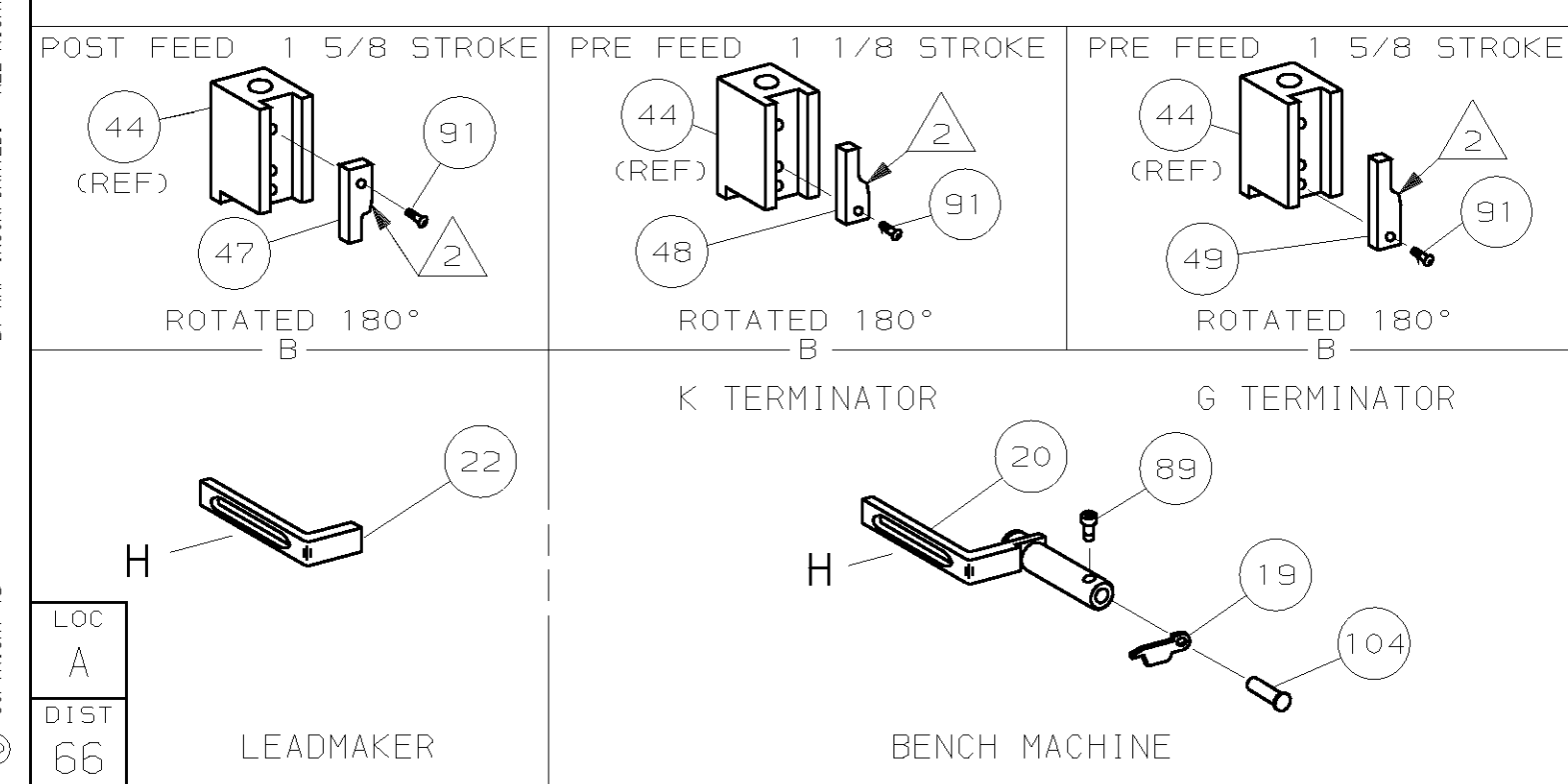
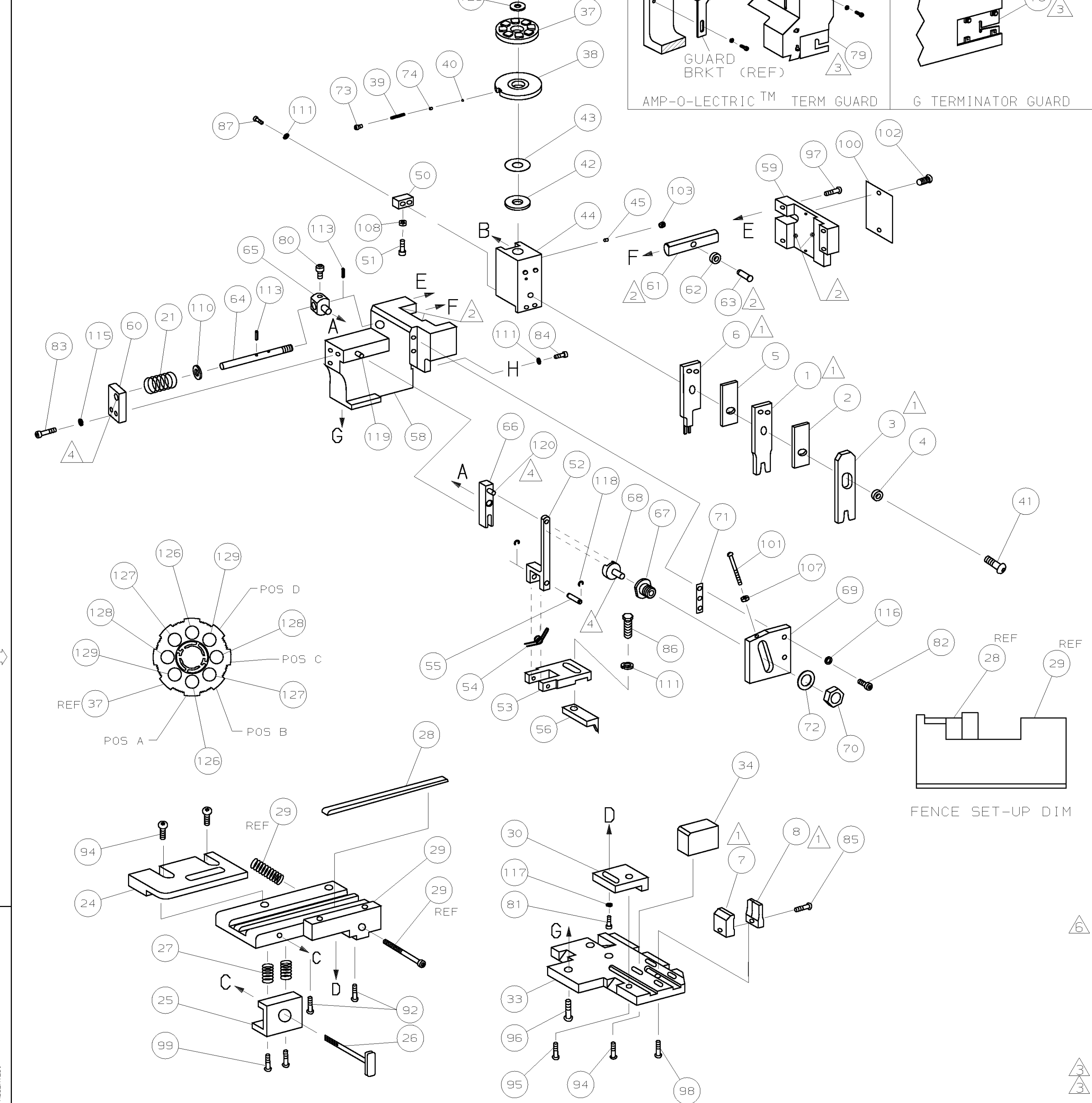

- 1 RECOMMENDED SPARE PARTS.
- 2 GREASE LIGHTLY.
- 3 GUARD MUST BE IN PLACE WHEN OPERATING APPLICATOR IN A BENCH MACHINE.
- 4 LUBRICATE DAILY USING NO. 20 MACHINE OIL.
- 5. ITEMS WITH QTY OF REF SPECIFIED (EXCEPT ITEMS 78 AND 79) ARE USED ON ITEM 46.
- 6 CUT TO LENGTH AT ASSY

TERMINAL NAME: TERMINAL CONTACT FOR T-5 WEDGE BASE LAMPS			
286805	CRIMP DATA	(NON-AMP TERMINAL-CUST SPEC)	
PAD LTR	CRIMP HEIGHT	WIRE SIZE	
A	.062 ±.002 [1.57 ±0.05mm]	16	
B	NOT	USED	
C	NOT	USED	
D	NOT	USED	
CRIMP SIZE		TYPE	RANGE
WIRE	.080 [2.03mm]	F	16
INSUL	.118 [3.00mm]	F	.062 MAX
WIRE STRIP LENGTH	TERM APPL SPEC	FEED	APPL INSTRUCTION
.155-.203	NONE	.492	408-8040
SET UP GAGE		LAYOUT	
458637-1		L2231	

QTY	RECD	PER	ASSY	U/M	DWG SIZE	PART NO	DESCRIPTION	ITEM NO
1	1	1	-	-	-	129		129
1	1	1	-	-	-	128		128
1	1	1	-	-	-	127		127
2	2	2	-	-	-	354779-8	PIN, WIRE DISC (.3030)A	126
1	1	1	-	-	-	986950-1	WASHER, FLAT PRECISION	125
1	1	1	-	-	-	217238-1	GENERAL INSTRUCTION PACKAGE	124
1	1	1	-	-	-	4088040	SF APPL INST 408-8040	123
1	1	1	-	-	-			122
1	1	1	-	-	-	4-21028-0	PIN,SLT SPR(Ø.093x.75)ST GDE PL	121
1	1	1	-	-	-	1-21030-1	PIN,DOWEL(Ø.187x.50)LEVER	120
1	1	1	-	-	-	1-21030-6	PIN,DOWEL(Ø.187x1.25)HOUSING	119
1	1	1	-	-	-	21045-3	RING,RET "C"(Ø.187)FD FING PIN	118
1	1	1	-	-	-	21024-5	WASHER, LOCK(#10)ADJ BLOCK	117
1	1	1	-	-	-	21024-5	WASHER,LOCK(#10)ADJ PLATE	116
1	1	1	-	-	-	21024-5	WASHER,LOCK(#10)FEED GDE ROD	115
1	1	1	-	-	-			114
1	1	1	-	-	-	5-21028-1	PIN,SLT SPR(Ø.125x.50)ADJ ROD	113
1	1	1	-	-	-			112
4	4	4	-	-	-	21024-4	WASHER, LOCK(#8)STRIPPER	111
1	1	1	-	-	-	21899-4	WASHER, FLAT(Ø5/16)SCREW ADJ	110
1	1	1	-	-	-			109
1	1	1	-	-	-	21018-5	NUT, HEX(NO. 6)HOLDDOWN	108
1	1	1	-	-	-	21068-5	NUT, HEX(6-32)FEED ADJ	107
1	1	1	-	-	-			106
1	1	1	-	-	-			105
1	1	1	-	-	-	992031-1	PIN, CLEVIS	104
1	1	1	-	-	-	21009-2	SCR,SKT SET(1/4-20x.25 LW)RAM	103
2	2	2	-	-	-	21017-2	SCR,DRIVE(#2x.19)ID PLATE	102
1	1	1	-	-	-	6-23715-5	SCR,PAN HD(6-32x1.50)FEED ADJ	101
1	1	1	-	-	-	461264-1	PLATE, IDENTIFICATION	100
2	2	2	-	-	-	3-21002-0	SCR,BHC(10-32x.88)DRAG	99
1	1	1	-	-	-	22733-8	SCR,BHC(8-32x.38 LW)ANVIL	98
1	1	1	-	-	-	2-21002-9	SCR,BHC(10-32x.75)CAP	97
1	1	1	-	-	-	2-22733-8	SCR,BHC(1/4-20x.62)HOUSING	96
1	1	1	-	-	-	2-21002-7	SCR,BHC(10-32x.50)56 ADJ BLOCK	95
4	4	4	-	-	-	2-21002-2	SCR,BHC(8-32x.50)TERM H DWN	94
1	1	1	-	-	-			93
2	2	2	-	-	-	1-21002-4	SCR,BHC(4-40x.38)FENCE	92
1	1	1	-	-	-	1-21002-7	SCR,BHC(6-32x.38)CAM	91
1	1	1	-	-	-			90
1	1	1	-	-	-	7-21000-9	SCR,SHC(4-40x.19)STRIPPER	89
1	1	1	-	-	-			88
2	2	2	-	-	-	2-21000-7	SCR,SHC(8-32x.48)DEP-HOLD	87
1	1	1	-	-	-	2-22603-0	SCR,HEX HD(8-32x.31)FEED FINGER	86
1	1	1	-	-	-	2-21000-8	SCR,SHC(8-32x.62)SHEAR	85
1	1	1	-	-	-	2-21000-7	SCR,SHC(8-32x.50)STRIPPER	84
1	1	1	-	-	-	3-21000-7	SCR,SHC(10-32x.75)FEED ROD GD	83
1	1	1	-	-	-	3-21000-6	SCR,SHC(10-32x.62)FD ADJ BLK	82
1	1	1	-	-	-	3-21000-4	SCR,SHC(10-32x.38)56 ADJ BL	81
1	1	1	-	-	-	3-21000-4	SCR,SHC(10-32x.38)PIVOT BLK	80
-	1	1	-	-	-	455749-1	GUARD, WINDOW	79
REF	-	-	-	-	-	679532-1	INSERT, GUARD	78
								77
								76
								75
1	1	1	-	-	-	690603-1	SPRING, ASSIST	74
1	1	1	-	-	-	23030-1	SCR,SHC(6-32x.25 SL)INS DISC	73
1	1	1	-	-	-	458109-1	WASHER, SPECIAL	72
1	1	1	-	-	-	690517-1	SPACER	71
-3	-2	-1	U/M	DWG SIZE		PART NO	DESCRIPTION	ITEM NO

QTY	RECD	PER	ASSY	U/M	DWG SIZE	PART NO	DESCRIPTION	ITEM NO
1	1	1	-	-	-	1320412-1	ANVIL	8
1	1	1	-	-	-	853714-9	PLATE, REAR SHEAR	7
1	1	1	-	-	-	853720-8	BLADE, SLUG	6
1	1	1	-	-	-	455888-8	SPACER	5
1	1	1	-	-	-	238009-8	SPACER, BLOCK CRIMPER	4
1	1	1	-	-	-	9-683453-9	CRIMPER, INSULATION	3
1	1	1	-	-	-	455888-4	SPACER, CRIMPER	2
1	1	1	-	-	-	1-456405-4	CRIMPER, WIRE	1
-3	-2	-1	U/M	DWG SIZE		PART NO	DESCRIPTION	ITEM NO

QTY	RECD	PER	ASSY	U/M	DWG SIZE	PART NO	DESCRIPTION	ITEM NO
1	1	1	-	-	-	1320413-1	GUIDE, STRIP (REAR)	24
-	-	1	-	-	-	690472-2	STRIPPER	22
1	1	1	-	-	-	4-22284-9	SPRING, FEED RETURN	21
1	1	1	-	-	-	679218-1	STRIPPER WIRE STOP ASSY	20
1	1	1	-	-	-	458949-1	STRIPPER	19
1	1	1	-	-	-			18
1	1	1	-	-	-			17
1	1	1	-	-	-			16
								15
								14
								13
								12
								11
								10
								9
								8
								7
								6
								5
								4
								3
								2
								1

DIMENSIONS IN INCHES. DO NOT SCALE PRINT. TOLERANCES UNLESS OTHERWISE SPECIFIED: 2 PLC DEC ±, 3 PLC DEC ±, 4 PLC DEC ±, ANGLES ±, SURF TEXTURE: REMOVE BURRS, BREAK SHARP EDGES R.015 MAX

MATL: HT TR: FIN:

DR: B.HIGMAN 18MAY99 APP: T.ELBIN 18MAY99

CHK: B.HIGMAN 18MAY99 REL: B.HIGMAN

NAME: SIDE FEED HDM APPLICATOR MACHINE REF: MINI APPL

SCALE: DWG NO: 680820 SHEET 1 OF 1 REV B

CUSTOMER AND ASSEMBLY DRAWING