

RECOMMENDED P.C. BOARD HOLE LAYOUT

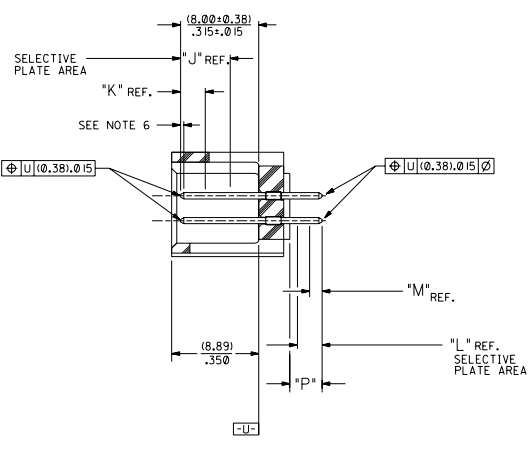

SECTION J-J

NOTES:

- 1- 20 CIRCUIT SIZE SHOWN FOR ILLUSTRATION PURPOSES.
- 2- PIN PUSHOUT FORCE: (17.79 N)/4 LBS.
- 3- PINS MUST MEET SOLDERABILITY SPEC. MIL-STD-202 METHOD 208B.
- 4- WINDOW NOT AVAILABLE ON 6 AND 8 CIRCUIT SIZE.
- 5- FOR CHARTED DIMENSIONS AND ASSEMBLY NO.S NOT SHOWN ON THIS SHEET - SEE SHEET 2.
- 6- ROW TO ROW PIN HEIGHT VARIATION MUST NOT EXCEED (0.13)/.005 IN.
- 7- PRODUCT CONFORMS TO PS-8723.

MATERIAL:

SHROUDED WAFER: GLASS FILLED POLYESTER, 94V-0; COLOR: BLACK.  
PINS: PHOSPHOR BRONZE,  
SEE SHEET 2 FOR FINISHES.

ASSEMBLY STYLE "A" AND "B"

CKT.	DIM. "A"		DIM. "B"		DIM. "C"		DIM. "D"		DIM. "E"	
	INCH	MILL	INCH	MILL	INCH	MILL	INCH	MILL	INCH	MILL
06	(1.68) .066	(8.43) .332	(5.08) .200	(1.68) .066						
08	(1.68) .066	(10.97) .432	(7.62) .300	(1.68) .066						
10	(1.68) .066	(13.51) .532	(10.16) .400	(4.22) .166						
12	(1.68) .066	(16.05) .632	(12.70) .500	(4.22) .166						
14	(1.68) .066	(18.59) .732	(15.24) .600	(6.76) .266						
16	(1.68) .066	(21.13) .832	(17.78) .700	(6.76) .266						
18	(1.68) .066	(23.67) .932	(20.32) .800	(9.30) .366						
20	(1.68) .066	(26.21) 1.032	(22.86) .900	(1.68) .066	(19.46) .766					
22	(1.68) .066	(28.75) 1.132	(25.40) 1.000	(1.68) .066	(22.00) .866					
24	(1.68) .066	(31.29) 1.232	(27.94) 1.100	(1.68) .066	(24.54) .966					
26	(1.68) .066	(33.83) 1.332	(30.48) 1.200	(1.68) .066	(27.08) 1.066					
28	(1.68) .066	(36.37) 1.432	(33.02) 1.300	(1.68) .066	(29.62) 1.166					
30	(1.68) .066	(38.91) 1.532	(35.56) 1.400	(1.68) .066	(32.16) 1.266					
32	(1.68) .066	(41.45) 1.632	(38.10) 1.500	(1.68) .066	(34.70) 1.366					
34	(1.68) .066	(43.99) 1.732	(40.64) 1.600	(1.68) .066	(37.24) 1.466					
36	(1.68) .066	(46.53) 1.832	(43.18) 1.700	(1.68) .066	(39.78) 1.566					
38	(1.68) .066	(49.07) 1.932	(45.72) 1.800	(1.68) .066	(42.32) 1.666					
40	(1.68) .066	(51.61) 2.032	(48.26) 1.900	(1.68) .066	(44.86) 1.766					
42	(1.68) .066	(54.15) 2.132	(50.80) 2.000	(1.68) .066	(47.40) 1.866					
44	(1.68) .066	(56.69) 2.232	(53.34) 2.100	(1.68) .066	(49.94) 1.966					
46	(1.68) .066	(59.23) 2.332	(55.88) 2.200	(1.68) .066	(52.48) 2.066					
48	(1.68) .066	(61.77) 2.432	(58.42) 2.300	(1.68) .066	(55.02) 2.166					
50	(1.68) .066	(64.31) 2.532	(60.96) 2.400	(1.68) .066	(57.56) 2.266					
52	(1.68) .066	(66.85) 2.632	(63.50) 2.500	(1.68) .066	(60.10) 2.366					
54	(1.68) .066	(69.39) 2.732	(66.04) 2.600	(1.68) .066	(62.64) 2.466					
56	(1.68) .066	(71.93) 2.832	(68.58) 2.700	(1.68) .066	(65.18) 2.566					
58	(1.68) .066	(74.47) 2.932	(71.12) 2.800	(1.68) .066	(67.72) 2.666					
60	(1.68) .066	(77.01) 3.032	(73.66) 2.900	(1.68) .066	(70.26) 2.766					
62	(1.68) .066	(79.55) 3.132	(76.20) 3.000	(1.68) .066	(72.80) 2.866					
64	(1.68) .066	(82.09) 3.232	(78.74) 3.100	(1.68) .066	(75.34) 2.966					
66	(1.68) .066	(84.63) 3.332	(81.28) 3.200	(1.68) .066	(77.88) 3.066					
68	(1.68) .066	(87.17) 3.432	(83.82) 3.300	(1.68) .066	(80.42) 3.166					
70	(1.68) .066	(89.71) 3.532	(86.36) 3.400	(1.68) .066	(82.96) 3.266					
72	(1.68) .066	(92.25) 3.632	(88.90) 3.500	(1.68) .066	(85.50) 3.366					

- U ADD -3803 OPT  
DCP2004-2268  
DMORGAN 04/05/20
- T LEAD FREE  
USP2004-179  
R WHITE 04/04/26
- S ADD -3802 OPTION  
ECN #022004-052  
DMORGAN 04/01/2
- R2 TAB DIF DIM 6 CIR  
ECN #010999-0145  
DMORGAN 56/09/01

- RI ADD WDG LATCH NOTE  
ECN #010998-0399  
DMORGAN 56/06/23
- R ADDED SHEET 7
- O REMOVE FDP NO.S  
PER ECR NO US0225  
05-04-93 B.S.
- P CHGD WINDOW NOTES  
PER ECR NO US30316  
05-04-93 B.S.
- O CHANGED MATERIAL  
PER ECR NO US3046  
01-22-93 B.S.
- R2 REVISED & REDRAWN  
PER ECR NO US2073  
05-29-92 B.S.
- LTR REVISIONS

DIMENSIONS SHOWN METRIC INCH  
 UNLESS OTHERWISE SPECIFIED  
 1/16" = 0.0625" 1/32" = 0.03125" 1/64" = 0.015625"

SALES ASSEMBLY  
 WAFER - STRAIGHT MT. FULLY SHROUDED  
 .1000 GRID - FOR USE W/ .0025 SQ. PINS  
 WITH .066 END WALLS

MOLEX INCORPORATED  
 1 OF 7 92/07/17

SEE CHART SDA-8723-\*\*\*\*\*

FILE NO. 58723A11  
 SCALE 4:1

DATE: 08/02/92  
 DRAWN: J. L. DA...  
 CHECKED: J. L. DA...  
 APPROVED: J. L. DA...

