

THIS SPECIFICATION SHEET FORMS A PART OF THE LATEST ISSUE OF RAYCHEM SPECIFICATION 1200.

CONSTRUCTION DETAILS

ELECTRICAL CHARACTERISTICS

DIMENSIONS ARE NOMINAL VALUES IN INCHES UNLESS OTHERWISE DESIGNATED.

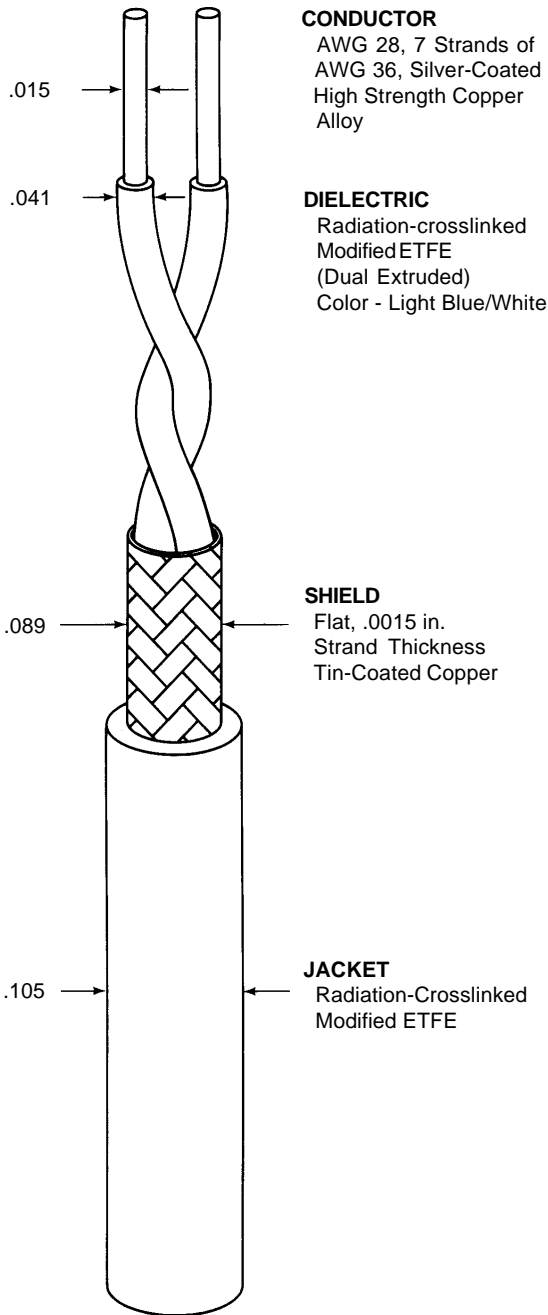

CONDUCTOR
AWG 28, 7 Strands of
AWG 36, Silver-Coated
High Strength Copper
Alloy

DIELECTRIC
Radiation-crosslinked
Modified ETFE
(Dual Extruded)
Color - Light Blue/White

SHIELD
Flat, .0015 in.
Strand Thickness
Tin-Coated Copper

JACKET
Radiation-Crosslinked
Modified ETFE

CHARACTERISTIC IMPEDANCE	100 ± 10 ohms at 1 MHz , test per ASTM D 4566, Method 2, Option 1, (Open and Short Circuit Measurement)
CAPACITANCE - MUTUAL	16.9 pF/ft. (nominal) 20.0 pF/ft. (maximum)

ADDITIONAL REQUIREMENTS

COMPONENT WIRE PRIOR TO CABLING (Test Procedures per SAE AS22759)

CROSSLINK PROOF	300 ± 3°C for 1 hour, .500 inch mandrel, .375 lb., 2.5 kV dielectric test
LOW TEMPERATURE COLD BEND SHRINKAGE	-65 ± 2°C for 4 hours, .375 inch mandrel, .500 lb., 2.5 kV dielectric test 200 ± 3°C for 1 hour, .125 inch (maximum) in 12 inches
INSULATION RESISTANCE INSULATION (DIELECTRIC) (total insulation)	5000 megohms for 1000 ft. (minimum)
TENSILE STRENGTH ELONGATION	5000 lbf/in ² (minimum) 50% (minimum)
INSULATION FLAWS SPARK TEST IMPULSE TEST	3.0 kV (rms) 8.0 kV (peak)

FINISHED CABLE (Test Procedures per NEMA WC27500)

BLOCKING	200°C for 6 hours
LOW TEMPERATURE COLD BEND	-55 ± 5°C for 4 hours, 3.0 inch mandrel
CROSSLINKED VERIFICATION	300 ± 5°C for 6 hours, 3.0 inch mandrel
FLAMMABILITY (Method B per Spec. 1200)	3 seconds (maximum); 3.0 inches (maximum), no flaming of facial tissue
JACKET FLAWS SPARK TEST IMPULSE TEST	1.0 kV (rms) 6.0 kV (peak)
JACKET TENSILE STRENGTH ELONGATION	5000 lbf/in ² (minimum) 50% (minimum)
SHIELD COVERAGE	90% (minimum)
JACKET THICKNESS	.008 (nominal)
VOLTAGE WITHSTAND (DIELECTRIC)	1500 volts (rms)
WEIGHT	6.6 lbs/1000 ft. (nominal)

OUTER SPACE REQUIREMENTS

RADIATION RESISTANCE	500 megarads/3.25 inch mandrel
VACUUM STABILITY TOTAL MASS LOSS (TML) VOLATILE CONDENSABLE MATERIAL (VCM)	1.0% (maximum) 0.1% (maximum)
WEIGHT LOSS: (Test per Spec 55/)	0.45% (maximum)

Outer jacket color will be white (designated by a "-9" appended to the part number, e.g. 0028A0664-9) unless otherwise specified.

Designate outer jacket color with a dash number in accordance with MIL-STD-681. Other codes and suffixes may be added to the part number, as necessary, to capture any additional requirements imposed by the purchase order.

Users should evaluate the suitability of this product for their application. Specifications are subject to change without notice.

Tyco Electronics also reserves the right to make changes in materials or processing, which do not affect compliance with any specification, without notification to Buyer.